

User Guide

BHFS – Borehole Fluid Sampler



Advanced Logic Technology

Bat A, Route de Niederpallen
L-8506 Redange-sur-Attert
Luxembourg

Phone : +352 23 649 289
Email : support@alt.lu
Web : www.alt.lu

Mount Sopris Instrument Company

4975 East 41st Avenue
Denver, Colorado 80216
USA

Phone : +1 303 279 3211
Email : tech.support@mountsopris.com
Web : www.mountsopris.com

Table of Contents

| | | |
|----------|------------------------------------|-----------|
| 1 | General Information | 5 |
| 1.1 | Dimensions | 5 |
| 2 | Measurement Principle | 7 |
| 3 | Operating Procedure | 8 |
| 3.1 | Sample Collection | 8 |
| 3.2 | Sample Removal | 8 |
| 4 | Maintenance | 13 |

1 General Information

The BHFS probe is a discrete point fluid sampler. The probe is lowered to a specific interval within the borehole, the sample chamber is opened, once the 1 or 2-liter sample chamber is filled a piston closes the chamber and the probe is brought to the surface. Once the probe is at the surface you open the valve located at the bottom of the probe and the sample can be drained into your sample container.

The tool is supplied as a stand-alone tool.

The BHFS operates with Scout, Matrix and Opal logging systems and can be run on any standard wireline (mono, 4 or 7 conductor, coax).

1.1 Dimensions

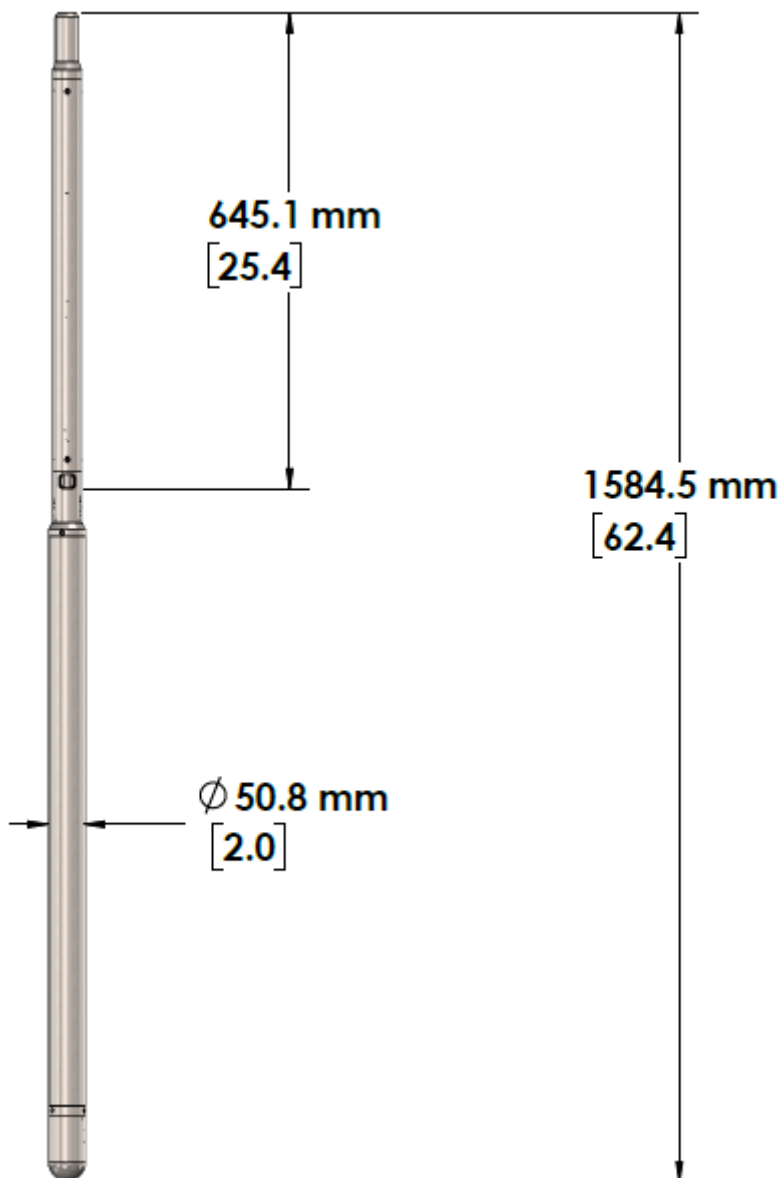

Figure 1-1 BHFS Dimensions Technical Specification

Tool

Weight (1-liter housing): 9.5 Kg (21lbs)
Diameter: 51 mm (2.0")
Length (1-liter housing): 1.58 m (62.4")
Sample point: 0.65 m (25.4") from top of probe top

Weight (2-liter housing): 13.8 Kg (30.5lbs)
Diameter: 51 mm (2.0")
Length (2-liter housing): 2.35 m (92.8")
Sample point: 0.65 m (25.4") from top of probe top

Min. Temp.: 0 °C (32 °F)
Max. Temp.: 70 °C (158 °F)
Max. Pressure: 200 bar (2900 psi)

Cable:

Cable type: Mono, Coaxial, 4 or 7 conductor
Compatibility: Scout, Opal, Matrix

Sample Chamber:

1 L (0.26 gal)
2 L (0.53 gal)

Power:

DC voltage at probe top: Min 90 VDC
Max 120 VDC
Nominal 120 VDC
Current: Nominal 25 mA (can exceed 200 mA under pressure)

2 Measurement Principle

The BHFS has a motor in the probe that is operated by applying a voltage down the wireline. The motor rotates an acme screw depending on the polarity of the voltage applied, which in turn pulls or pushes a shuttle that is connected to the chamber piston. When the piston is in the open position water enters the sample chamber. After the sample is collected a small O-ring attached to the piston seals the sample in the sample chamber.

3 Operating Procedure

3.1 Sample Collection

Caution: Before placing the probe in the borehole, be sure the sample chamber valve is in the closed position. This means the piston is fully engaged into the body portion and no O-ring is showing on the piston. You should also verify the lower bleed valve is closed as well. You can check this by removing the bull nose from the bottom of the probe and turning the valve handle to ensure it is in the closed position.

Place the probe in the hole and lower it so that the probe top cable head interface is at the zero reference for your work. Then, select the upper right-hand icon on the depth window. When the depth screen comes up, press Zero Tool. The depth setting will be set to 0.65 m, which is the depth to the sample port. The probe sample chamber extends below this port about 0.94 m.

Lower probe to desired sampling depth. To take a sample at a given depth go to Tool Settings selection, and click on it. A "Caliper Open/Close" dialog box will appear. Press Open to open the sample port. A small display with little blue squares will indicate that power is being applied (and the voltage and current displays on the Tool Power window will indicate the motor load. It takes about 10 seconds for the valve to open, and about 2 minutes for the sampler to fill. The amount of time it takes for the valve to open and the chamber to fill is dependent on a number of variables such as depth, chamber size, and static head in the well. At greater depths with more pressure the chamber will fill more rapidly, but at the same time the longer wireline and increased pressure may cause the valve to close a bit slower. Once the sample chamber is filled you then then press Close, and a similar status indication will appear, with the blue squares. You will also notice that during the closing of the sample chamber under higher pressures the current will increase. The piston sealing the sample chamber is working against higher pressures causing the motor to work a bit harder which in turn will draw more current to produce the force required to close the sample chamber.

Monitoring the current meter of the tool supply on the Dash Board can be useful in knowing when the probe is finished opening or closing. The current will return to a value of zero or near zero with only a few milli-amps showing once the valve is in a fully open or closed position.

Return the probe to the surface and follow the instructions below for opening the sampler.

3.2 Sample Removal

Caution: *WEAR EYE PROTECTION when working with the valves on the surface!*

Warning: *Never open the sample chamber valve with a pressurized sample in the volume. Doing so will lead to premature failure of the motorized valve seal. Always relieve the sample pressure with the bottom valve first.*

Place the probe in a stable position.

Remove the bull nose valve cap located at the bottom of the probe.



Attach an end of appropriate tubing to the outlet valve tube and your sample collection container or hold the bottom valve outlet tube over the sample collection container. When the joints are secure, open the bottom valve being careful to aim the bottom valve outlet tube away from your body.



To speed up transfer, after the sample chamber pressure is relieved, you can open the motorized valve with the probe still attached to the cable line and logger. Be certain close once done and before returning the probe to borehole for another sampling run.



*Note: The bottom valve outlet tube is nominally, 3/16" diameter.
If you want to pour the contents out of the sample chamber you should first bleed off any pressure by opening the bottom valve. Be careful to aim the valve outlet away from your body. Close the bottom valve and unscrew the sample chamber at the sample port body. Now you can pour the chamber contents into a container.*

Note: The bottom valve threads into a 1/4" NPT hole. If you replace the valve type or outlet tube diameter, test for clearance with the valve cap.

When the sample has been transferred, clean the sample chamber by an appropriate method. If you have not already done so, close the valve, replace the valve cap and remove the probe from the wireline. Replace the protective cap on the probe top. Test and replace O-rings in the valve piston at regular intervals if the probe is in high use.



4 Maintenance

The BHFS should only require minor maintenance to the mechanical end of the probe. When possible, clean and flush mud and or contaminants out of the sample chamber and valve body and replace the O-rings on the sampler piston. Keep the sampler piston O-rings lubricated with non-reactive O-ring lubricant. Below are instructions on how to access the O-rings and the part numbers. If electronic or mechanical troubleshooting becomes necessary, contact a qualified technician.

Piston O-rings: 25-402-106

Sample Chamber O-rings: 25-402-222

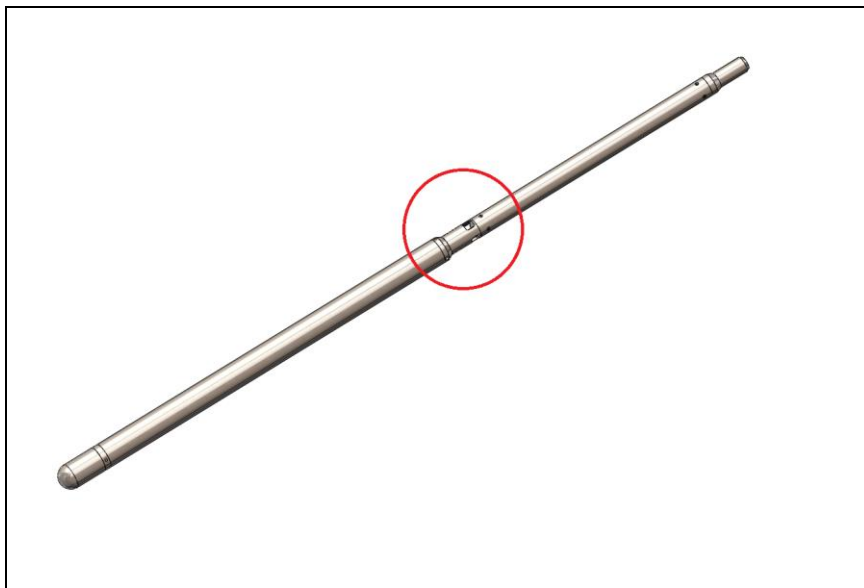

To access the piston, you must first remove the four radial screws for the outer housing.



Once the radial screws have been removed you can slide the outer housing away from the bulkhead.

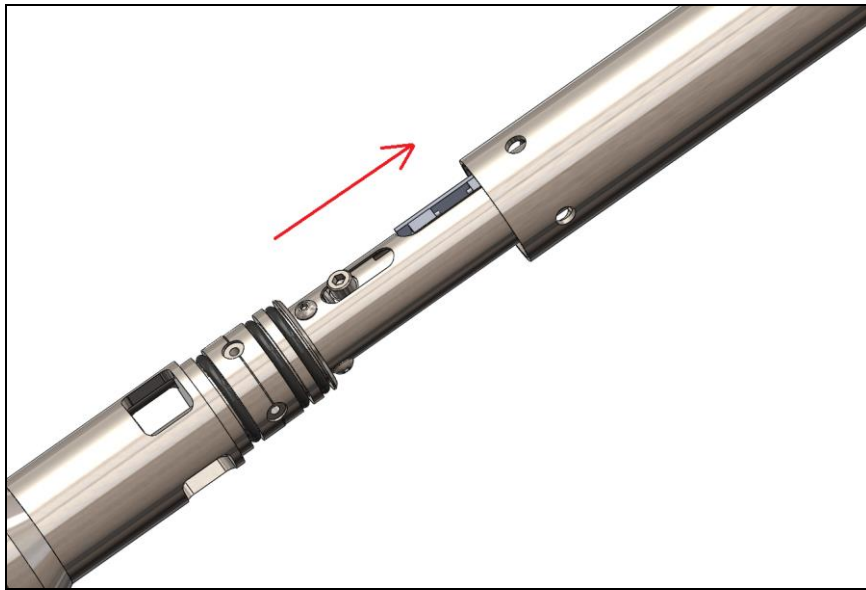

This will expose the gland portion of the bulkhead and the O-rings. Next, you will need to remove the three button-head screws.

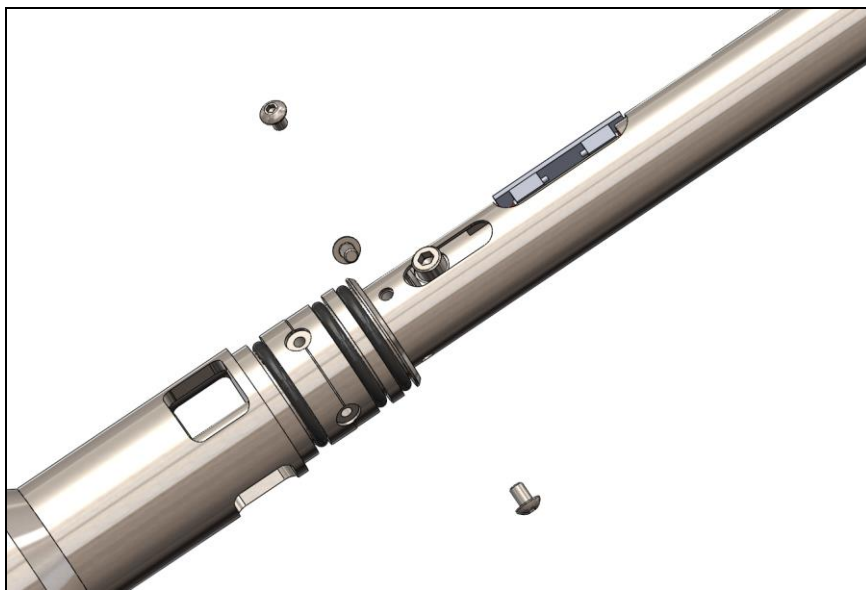

You can now slide the motor housing away from the bulkhead, exposing the piston and O-rings.

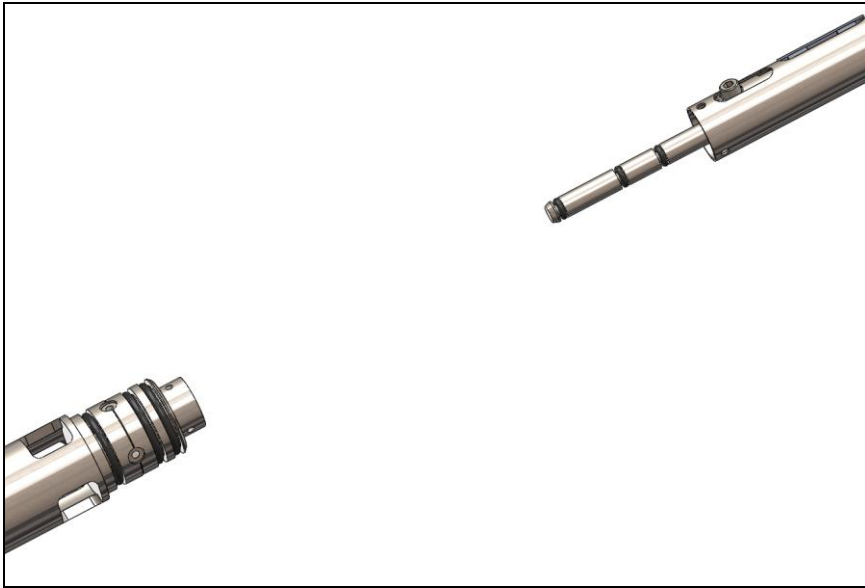

To remove the piston, you will need to remove the single fixing bolt, being careful not to twist the piston shuttle.

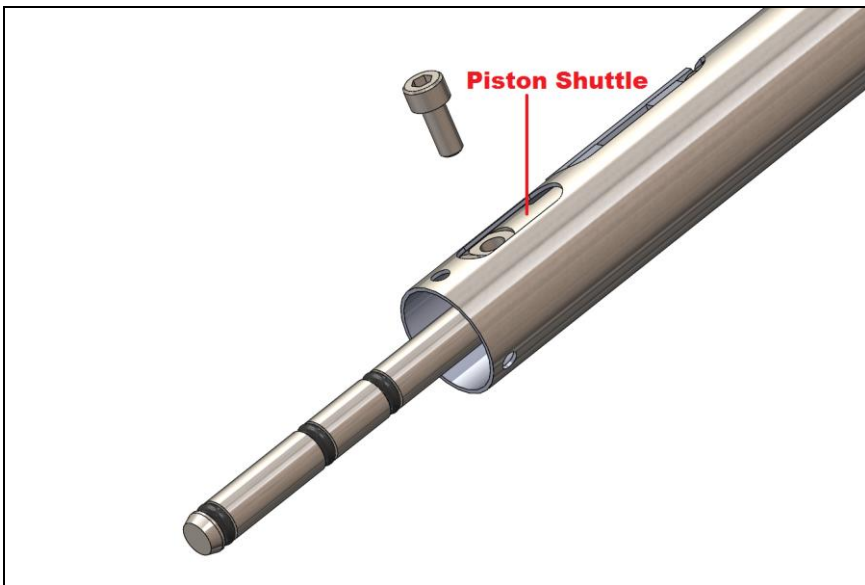

You should now be able to remove the piston and perform any maintenance. When reassembling the probe, it is recommended that you use Blue Loctite 242 to hold all the bolts and screws in place. You will also want to make sure all O-rings are adequately lubricated.

