

User Guide

QL43 ABI – Acoustic Borehole Imager



Advanced Logic Technology sa

Zoning de Solupla
Route de Niederpallen, 30H
L-8506 Redange-sur-Attert
Luxembourg

Phone : +352 28 56 15 1
Email : support@alt.lu
Web : www.alt.lu

Mount Sopris Instruments Co., Inc.

4975 E. 41st Ave.
Denver, CO 80216
USA

Phone : +1 303 279 3211
Fax : +1 303 279 2730
Email : tech.support@mountsopris.com
Web : www.mountsopris.com

Table of Contents

1	General Information	5
1.1	Overview	5
1.2	Dimensions	6
1.3	Technical Specifications	7
2	Measurement Principle	9
2.1	Reflection coefficient	10
2.2	Acoustic head operation	10
3	Operating Procedure	13
3.1	Quick Start	13
3.2	Tool Communication with OPAL-SCOUT (ALT Modem)	14
3.3	Tool Communication with ALT Logger (ALT Shallow adapter)	15
3.4	Tool Communication with MATRIX	15
3.5	Configuring Tool Parameters	17
3.5.1	Operating Modes	17
3.5.2	Azimuthal resolution	26
3.5.3	Additional notes on the waveform preview	26
3.5.4	Advanced Settings	27
3.5.5	Tool details	27
3.6	Recorded Parameters and Browsers	30
3.6.1	Recorded parameters	30
3.6.2	MChNum Browser Window	31
3.6.3	Surface Image Browser Window (AbiSurfaceImg)	31
3.6.4	CADI Image Browser Window (AbiCadIImg)	33
3.6.5	Caliper Browser Window (AbiCaliper)	34
3.6.6	Wavelet Browser Window (AbiWavelet)	36
4	Performance Check & Calibration	37
4.1	Mirror rotation	37
4.2	Functionality test of the deviation system	37
4.2.1	Functionality test	37
4.2.2	Rolling test – azimuth and tilt check	37
5	Maintenance	39
5.1	Tool Head Adapter	39

5.2	Acoustic head	40
5.2.2	Level 1 maintenance.....	43
5.2.3	Level 2 maintenance.....	46
5.2.4	Removing oil from the head	47
5.2.5	Piston cleaning.....	48
5.2.6	Refilling oil	53
5.2.7	Replacing the Fluid Temperature Sensor enclosure O’ring.....	55
5.3	Handling the electronic cartridge	59
5.3.1	Extracting the electronic cartridge from the pressure housing	59
5.3.2	Inserting the electronic cartridge into the pressure housing.....	61
5.4	Changing the Quick Link connection O-rings.....	63
6	Troubleshooting.....	66
7	Notes on Data Processing.....	69
7.1	Estimation of Fluid Velocity.....	69
7.2	Computation of Caliper Data.....	70
7.3	Calculation of Casing Thickness.....	71
8	Appendix	73
8.1	Tool Communication with OPAL/SCOUT	73
8.2	Parts list	78
8.2.1	QL43 O-ring Spares kit (ref. 209-007).....	78
8.2.2	QL43 ABIHEAD – maintenance kit (ref. 209-006).....	78
	Index	79

1 General Information

The QL43 ABI is the latest generation of acoustic televiewer. Based on more than 10 years of experience and market leadership with BHTV technology, the new system consists of a completely redesigned acoustic head and new electronics in order to meet oil industry standards in terms of temperature and pressure ratings. The electronic architecture uses a 14 Bit A/D converter directly coupled to a superfast 333Mops DSP digital signal processor. The DSP is performing complex data processing operations in real time on each individual ultrasonic wave train and that allows a wider dynamic range of signal detection and easy field operation in a wide variety of logging applications.

1.1 Overview

Acoustic borehole scanner tools generate an image of the borehole wall by transmitting ultrasound pulses from a fixed transducer with rotating mirror and recording the amplitude - travel time of the signals reflected at the interface between borehole fluid and the formation (borehole wall). The QL43 ABI has multi-echo detection capability. This is achieved by digitally recording the reflected acoustic wave train. On line analysis of the acoustic data is made by the DSP. Sophisticated algorithms allow the system to detect the reflection from the acoustic window and to separate and classify all subsequent echoes. Minimum input from the operator is needed to enable:

- Automatic optimization of the measurement window under all borehole conditions.
- Automatic or manual adaptation to variable borehole conditions.
- Improved dynamic range of signal detection.
- Very high travel time resolution.
- The implementation of different operating modes. For example, when run inside casing, the tool can record both the echo of the casing and that of the borehole wall. With multi-echoes processing, application of the tool may be extended to casing thickness and corrosion evaluation.

Tool upgrades and the implementation of customized operating modes can be done by simply downloading new firmware to the tool from the surface computer.

1.2 Dimensions

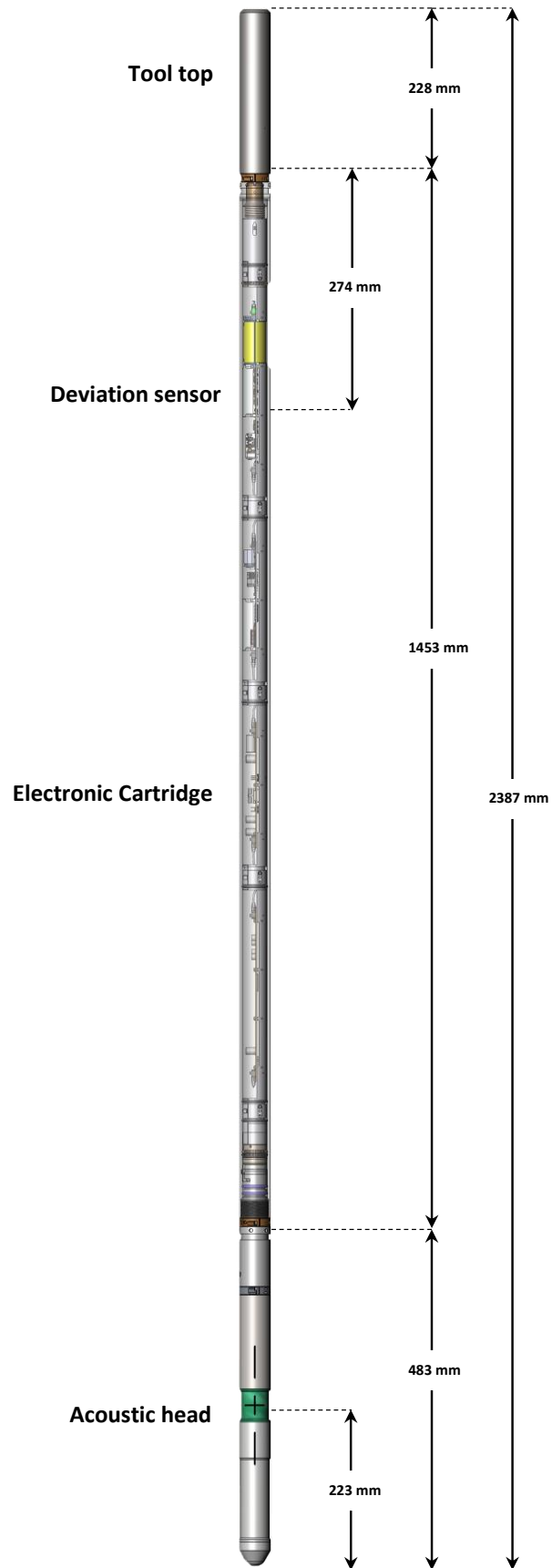

Figure 1-1 General arrangement

1.3 Technical Specifications

CARTRIDGE:

Diameter:	43 mm - 1 ^{11/16}
Length:	1.45 m - 4.8 ft ¹
Weight:	6.2 kg - 13.7 lbs ¹
Max. Temp:	170 °C – 338°F
Max. Pressure:	700 bar – 10,000 psi

ACOUSTIC HEADS:

Acoustic sensor:	Fixed transducer and rotating focusing mirror
Focusing:	Collimated acoustic beam
Frequency:	1.2 MHz
Acoustic beam width:	3 mm @ focal distance
Mirror rotation speed:	Up to 20 rev/sec - automatic
Azimuthal resolution:	72 – 144 or 288 (user defined)
Caliper resolution:	0.08 mm
Output:	Internal radius
(360° unwrapped image logs)	Amplitude
	Thickness
	Score
	CADI (Cement Attenuation Decay Index)

Acoustic Head Models

QL43 ABI HEAD OH-CO-L

Open Hole – Corrosion – Long Focus

Application:

Open Hole: up to 21" depending on borehole conditions

Cased Hole: 5^{1/2} to 15" with a minimum of 5mm casing thickness

Max. Temp. Open Hole: 170°C – 338°F

Max. Temp. Cased Hole: 150°C – 302°F

Max. Pressure: 700 bar – 10,000 psi

Weight: 2.8 Kg – 6.2 lbs

Length: 0.48 m – 1.57 ft

QL43 ABI HEAD CO-S

Corrosion – Small Focus

Application:

Cased Hole: 3" to 5^{1/2}" with a minimum of 3mm casing thickness

Max. Temp. Cased Hole: 150°C – 302°F

Max. Pressure: 700 bar – 10,000 psi

Weight: 2.8 Kg – 6.2 lbs

Length: 0.51 m – 1.57 ft

QL43 ABI HEAD CO-XXS

Corrosion – Extra Small Focus

Application:

Cased Hole: 2^{7/8}" with a minimum of 3mm casing thickness

Max. Temp. Cased Hole: 150°C – 302°F

Max. Pressure: 700 bar – 10,000 psi

Weight: 2.8 Kg – 6.2 lbs

Length: 0.51 m – 1.57 ft

¹ Cartridge only

ORIENTATION SENSOR:

Sensor: 3 axis fluxgate magnetometer
3 accelerometers

Location: Mid point @ 1.66 m from tool bottom

Inclination accuracy: +/- 0.5 deg

Azimuth accuracy: +/- 2.5 deg

OPERATING CONDITIONS:

Always centralized

Borehole fluid: Water
Water based mud
Brine
Pure oil (not applicable in oil based mud)

Wireline: Mono conductor
Multi-conductor
Coaxial

Acquisition system: OPAL
SCOUT-PRO

2 Measurement Principle

An understanding of the basic principles of operation of the televiwer is essential for successful use of the tool. The QL43 ABI televiwer produces images of the borehole wall which are based on the amplitude and time of travel of an ultrasonic beam reflected from the formation wall. The ultrasonic energy wave is generated by a specially designed piezoelectric ceramic crystal and has a frequency of around 1.2MHz. On triggering, an acoustic energy wave is emitted by the transducer and travels through the acoustic head and borehole fluid until it reaches the interface between the borehole fluid and the borehole wall. Here a part of the beam energy is reflected back to the sensor, the remainder continuing on into the formation medium at a changed velocity (**Figure 2-1**). By careful time sequencing the piezoelectric transducer acts as both transmitter of the ultrasonic pulse and receiver of the reflected wave. The travel time for the energy wave is the period between transmission of the source energy pulse and the return of the reflected wave measured at the point of maximum wave amplitude. The magnitude of the wave energy is measured in dB, a unit less ratio of the detected echo wave amplitude divided by the amplitude of the transmitted wave.

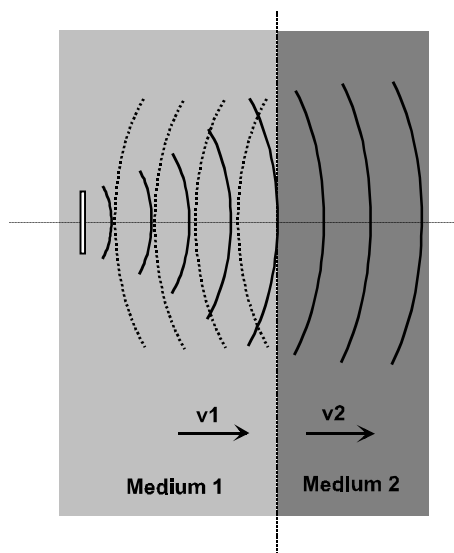

Figure 2-1 Wave propagation

2.1 Reflection coefficient

The strength of the reflected signal depends principally on the impedance contrast between the borehole fluid and the formation (**Figure 2-1**).

The reflection coefficient r is given by the following equation:

$$r = (\rho_b v_b - \rho_m v_m) / (\rho_b v_b + \rho_m v_m)$$

where $\rho_b =$ density of formation
 $\rho_m =$ density of borehole fluid
 $v_b =$ velocity of sound of formation
 $v_m =$ velocity of sound of borehole fluid

The larger the reflection coefficient the greater the signal reflection and thus the detectability. From the equation it may be seen that when the properties of the borehole fluid and borehole wall are similar, i.e. $\rho_b v_b \approx \rho_m v_m$, r approaches zero and there is negligible reflection. In this situation determination of the true reflected wave is made more difficult.

2.2 Acoustic head operation

The acoustic wave is generated by applying a high voltage pulse across the two faces of a piezo ceramic disc. The applied voltage causes deformation within the crystal structure, either an expansion or contraction depending on the polarity of the applied voltage, with a resultant energy wave emitted normal to the free surface. It has been shown that the beam generated by this process has a maximum energy at a distance of twice the diameter of the disc and that after this point the beam tends to diverge. In order to optimize the beam energy at the point of investigation the ALT televiwer head has been designed as illustrated below (

Figure 2-2).

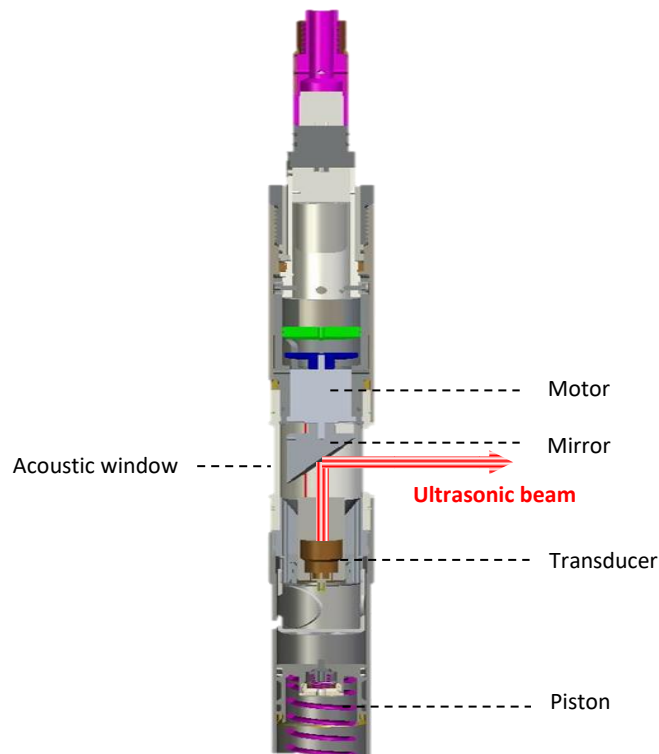

Figure 2-2 Focusing arrangement

The acoustic wave propagates along the axis of the tool body and is then reflected perpendicular to this axis by a special reflector that focuses the beam to a high-energy point of +/- 3 mm diameter.

The radial distance of the focal point from the axis of the tool is determined by the focal length of the mirror, +/- 108 mm ($4''^{1/4}$) for the QL43 ABI HEAD OHCO-L, +/- 57mm ($2''^{1/4}$) for the QL43 ABI HEAD CO-S and +/- 32mm ($1''^{1/4}$) for the QL43 ABI HEAD CO-XXS.

The frequency of the transmitted wave is determined amongst other factors such as ceramic composition by the diameter of the piezo transducer, a smaller diameter giving a higher frequency. The ALT televiewer operates around 1.2MHz.

The reflector is mounted on the drive shaft of a stepper motor. This enables the position of measurement to be rotated through 360°. Sampling rates of 72, 144 and 288 measured points per revolution are available, thus at maximum resolution a near continuous image of the borehole wall is made. The higher sampling rate can be used for better resolution in larger diameter boreholes but is less useful in small diameters due to overlap of the sampling points.

3 Operating Procedure

Note: Parts of the topics discussed in these sections below assume that the user is familiar with “LoggerSuite” acquisition software. Refer to the corresponding operator manuals for more details. Information about assembly and configuration of tool stacks can be found in the same manuals.

3.1 Quick Start

1. Connect the QL43 ABI to your wireline and start the data acquisition software.
2. Select the relevant QL43 ABI tool from the drop down list (Figure 3-1) in the software’s **Tool** panel (if your tool is not listed check that your tool configurations file is stored in the designated folder on your computer).
3. In the **Tool** panel switch on the tool (click **On** button) and verify that the power indicator shows a valid (green) level. The system goes through a short initialization sequence which sets the default parameters and communication settings held in the tool configuration file. The configuration returned by the tool is also checked during this procedure. (Setup tool communication as explained in chapter 3.5 if error message is displayed.)
4. On the **Tool** panel (Figure 3-1) click the **Settings / Commands** button to configure your tool for open hole/cased hole logging (see chapter 3.4 for details).
5. In the **Acquisition** panel (Figure 3-2) select the sampling mode (depth or time). Click on **Settings** and specify the corresponding sampling rate. Switch on the sampling (click the **ON** button).
6. Press the **Record** button in the **Acquisition** panel (Figure 3-3), specify a file name and start the logging.
7. During logging observe the controls in the **Telemetry** panel:
 - Status must be valid (green light);
 - Bandwidth usage in green range;
 - Memory buffer should be 0%;
 - Number of **Data** increases and number of **Errors** negligible.
 - Verify motor status (synchronization) in MChNum browser is valid.
 - **Do not log too fast! The Data/sec parameter must not exceed the speed of the motor rotating the mirror. Check against the MotSpeed displayed in the MChNum window.**

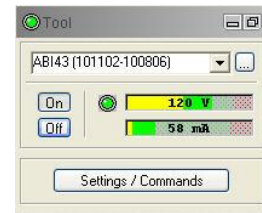

Figure 3-1 Tool panel



Figure 3-2 Acquisition panel

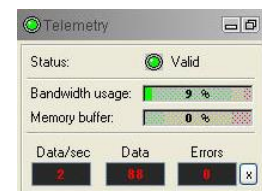
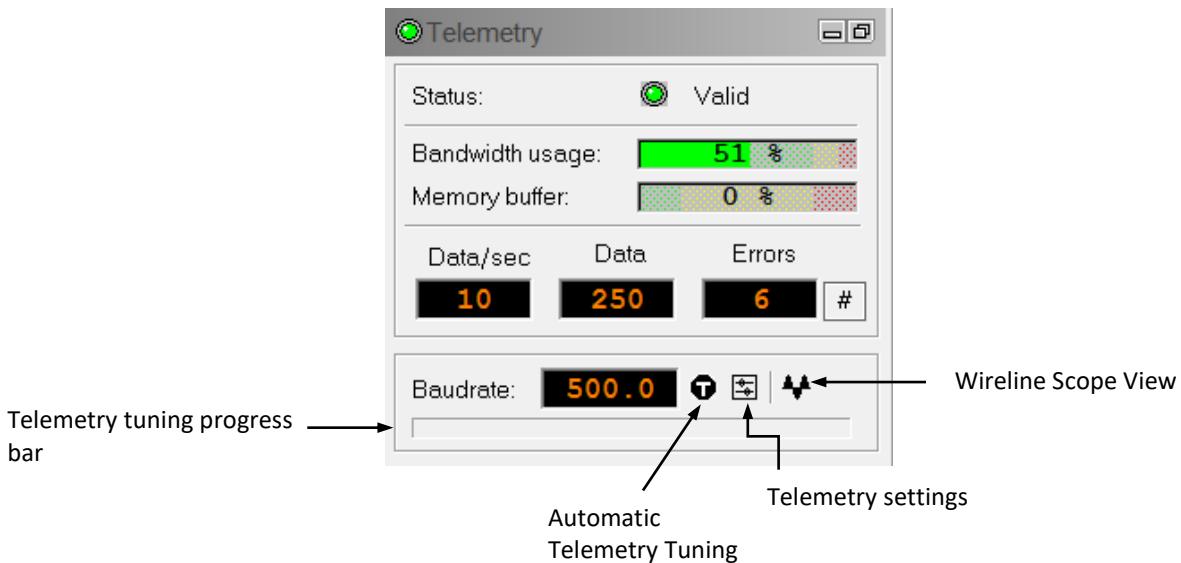

Figure 3-3 Telemetry panel

8. To end the logging procedure press the **Stop** button in the **Acquisition** panel and turn off the sampling (click **OFF** button).
9. In the **Tool** panel power off the tool.

3.2 Tool Communication with OPAL-SCOUT (ALT Modem)

The telemetry provided through the **OPAL-SCOUT** systems implementing the **ALT MODEM** controls and configures **AUTOMATICALLY** the telemetry settings for any wireline. In case communication status is not valid the user has different options to adjust manually the telemetry settings from the telemetry panel of the dashboard:



Baud rate:

Indicates the default baud rate or optimal baud rate in kbps found by the system for the selected winch/telemetry scheme

Automatic Telemetry Tuning:

The Tune button  resets the telemetry tuning automatically. This process defines:

- the optimum baud rate for the winch configuration selected
- a transfer function and a filter to re-construct at the surface the shape of the pulse trains distorted by the wireline.

A **progress bar** at the bottom of the telemetry window shows the progression of the telemetry tuning. At the end of the process the baud rate display is refreshed with the optimal baud rate value.

Refer to **Appendix** at the end of this manual for more information on the **advanced telemetry settings**.

3.3 Tool Communication with ALT Logger (ALT Shallow adapter)

The telemetry provided through the ALTLogger is self-tuning. In case communication status is not valid the user can manually adjust the settings. In the **Telemetry** panel of the dashboard click on **Settings** to display the **Configure Tool Telemetry** dialog box (Figure 3-4). A procedure to achieve valid communication is given below:

- Change the **Baudrate** to 41666 kbps.
- Verify that the **Downhole Pulse width** knob is set on 20 (default value). This value is the preferred one and is suitable for a wide range of wirelines. For long wireline (over 2000m), increasing the pulse width could help to stabilize the communication. The reverse for short wireline (less than 500m).
- Set the **Uphole** discriminators in the middle of the range for which the communication status stays valid.
- Increase the **Baudrate**, check the communication status stays valid and the **Bandwidth usage** (in **Telemetry** panel of the dashboard) is below the critical level.
- When **Uphole** discriminators are properly set, store the new configuration as default. The tool should go through the initialisation sequence the next time it is turned on.

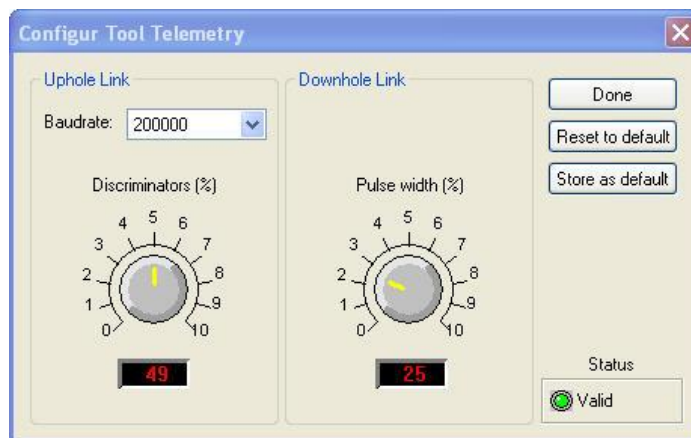

Figure 3-4 Tool communication settings

3.4 Tool Communication with MATRIX

The tool telemetry can be configured through the **Telemetry** panel of the Matrix dashboard. By clicking on **Settings**, the operator has access to the **Configure ALT Telemetry** dialog box (Figure 3-5) providing various controls to adjust the telemetry settings and monitor its current status.

The **Analysis View** displays the current discriminator levels (vertical yellow lines) and a histogram of the up-hole data signal. The scales of the **Analysis View** can be adjusted using the **Vertical Scale** and **Horizontal Scale** knobs and the **linear / logarithmic** scale buttons. The status of the configuration should be flagged as Valid (indicated by the LED being green). In any other case (LED red) the telemetry should be adjusted (we assume a pulse signal is displayed in the analysis view). Click on the **Advanced** button to display additional controls to tune the telemetry.

The Automatic settings option is the preferred mode and should allow the telemetry to be configured for a wide range of wirelines without operator input. For wirelines with a more limited bandwidth, the operator might need to turn off the automatic mode and adjust the telemetry settings manually.

For each wireline configuration, the discriminators (vertical yellow lines) for the **positive** and **negative** pulses must be adjusted in order to obtain a valid communication status (see **Figure**) for an example of a suitable discriminator position). There is also the option to alter the **baudrate** in order to optimize the logging speed. The input **gain** can be increased (long wirelines) or decreased (short wirelines) in order to set up the discriminator levels correctly.

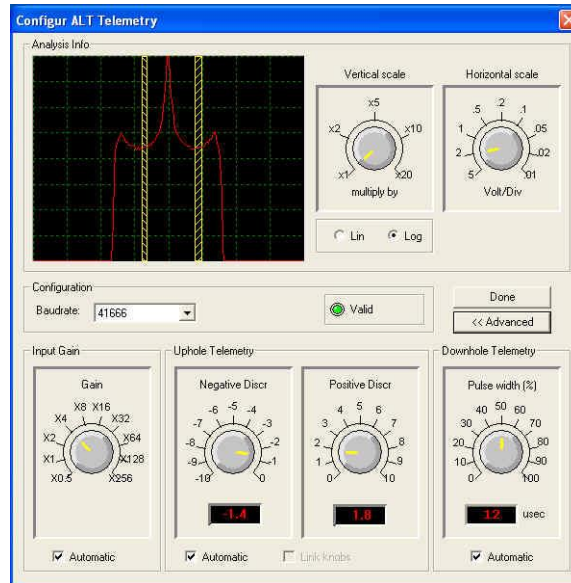

Figure 3-5 Matrix telemetry settings

Once the telemetry is correctly set, store the new settings as default. The tool should go through the initialization sequence in "Valid" status the next time the power is turned on.

3.5 Configuring Tool Parameters

The **Configure ABI Tool Parameters** dialog box (Figure 3-6) can be accessed by clicking on the **Settings / Command** button on the dashboard's **Tool** panel or by clicking on the tool's bitmap located in the **Tool Stack Manager** window.

3.5.1 Operating Modes

Three operating modes are possible for recording acoustic images with the QL40 ABI:

- Open hole mode
- Behind PVC mode
- Cased hole mode

3.5.1.1 Open Hole Mode

This record mode is used in open-hole conditions or to record the inner face of a casing.



Figure 3-6 Tool settings – Open Hole Mode (caliper scale here in µs)

When selecting a predefined bit size from the **“Bit Size”** dropdown list, the system configures in an automatic way the most adequate tool settings – azimuthal resolution, caliper max, echo gates - for the selected bit size or borehole nominal diameter. Note that User has always the choice to modify the tool settings as per his own requirements.

Imperial or **metric units** can be used for displaying the wave form preview and for configuring the caliper/echo gate settings.

The **“Open Hole”** mode gives access to two main tabs – **Caliper** and **Data** - for configuring the record:

Caliper tab:

Figure 3-7 Caliper and echo gate settings

In the **Caliper** page, the **Caliper Max.** knob (Figure 3-7) controls the extension of the real time preview of the ultrasonic waveform. It must be adjusted for the borehole diameter to investigate to allow detection and recording of the main echo.

Echo Gate settings are set in the “Auto” mode by default. If required, User can define a “**Start**” gate and specify the “**Length**” interval for recording the reflected echo. The tool firmware will pick up the strongest amplitude in the signal train within the Echo Gate and records amplitude and travel time of the borehole echo.

Note that the Echo Gate settings can also be adjusted interactively in the waveform preview.

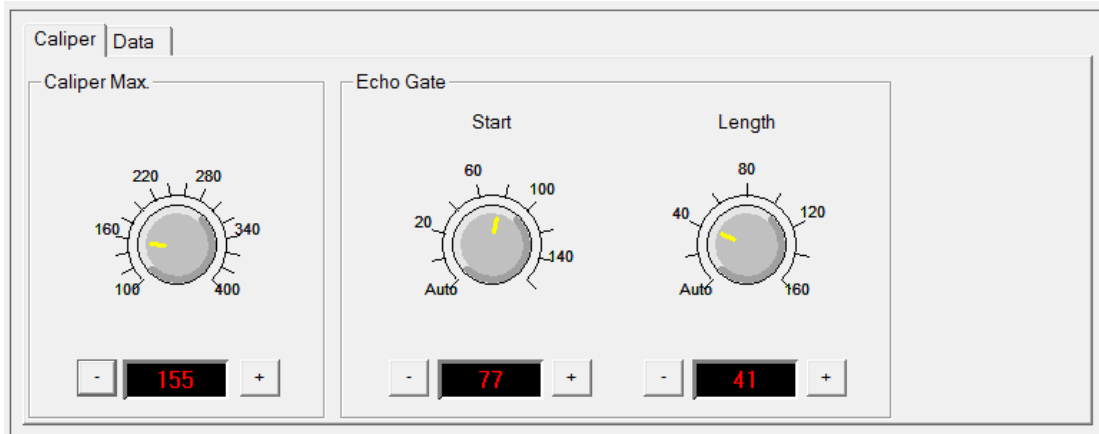
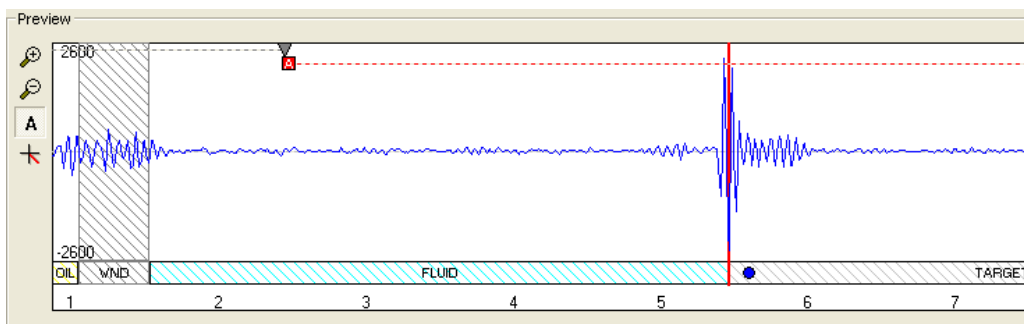



Figure 3-8 Waveform preview - Echo gate Automatic setting

For the open hole mode, the waveform preview allows the user to adjust the limits of two gates – the **Acoustic Window gate** and the **Echo Gate**.

The **Acoustic Window gate** is represented by a **grey dashed line** while the **Echo Gate** is shown as **red dashed line**.

The **Acoustic Window Gate** allows determination of the tool’s acoustic window reflection time.

The **Echo Gate “Start”** limit can be determined automatically or adjusted interactively in the preview. Square and triangle symbols indicate whether the limit of the “**Start**” gate is

automatically set (square symbol -  -) or if the user can adjust the limit with the mouse cursor (triangle - ).

Three modes are supported to set the **Start** time of the Echo Gate - To toggle from one mode to another **right click** on the square or triangle symbol.

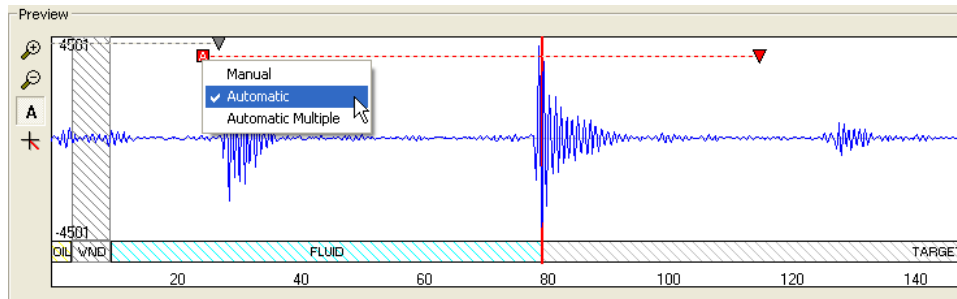

Figure 3-9 Toggling between Echo Gate detection modes

- **Automatic:** the system will automatically detect and record the highest amplitude occurring after the Acoustic Window Gate and the upper limit of the Echo Gate (Figure 3-10). Automatic is the recommended setting.

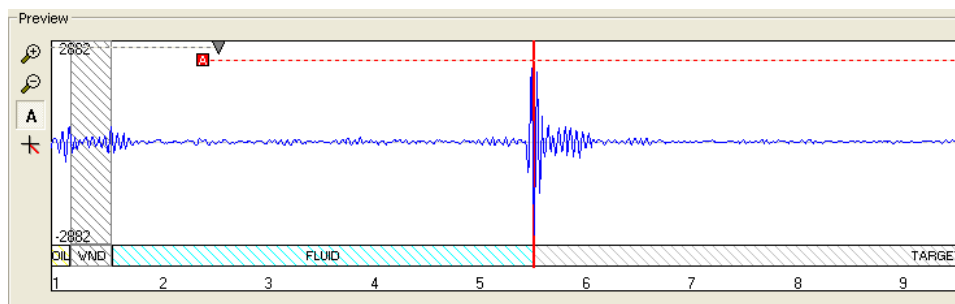

Figure 3-10 Start gate set in automatic mode

- **Automatic Multiple:** the system will automatically adjust the start time of the Echo Gate so that the first multiple of the Acoustic Window reflection is skipped. This setting is useful for large diameter boreholes when the amplitude of the first multiple of the Acoustic Window reflection is higher and arrives earlier than the echo from the borehole wall.
- **Manual:** Manual adjustment of the Echo Gate start time is useful to exclude noise with amplitudes higher than the formation signal (e.g. exclude the reflection from the inside of a PVC casing) – (Figure 3-11).

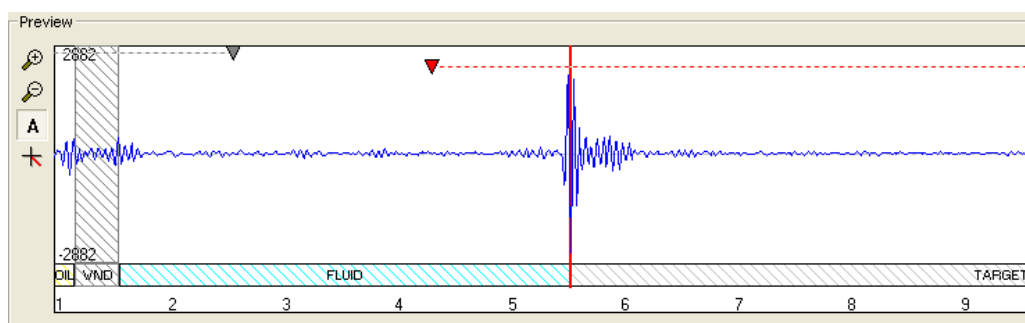

Figure 3-11 Start gate set in manual mode

Interactive adjustment in the waveform preview of the Echo Gate **Length** is also possible. It could be useful when multiple reflections with large amplitudes arrives towards the end of the gate period (e.g. exclude Acoustic Window reflection multiples when logging in soft formations).

To toggle the Echo Gate **Length** from the automatic to the manual mode, place your cursor at the right end of the red dashed line to display the double arrows symbol. Drag then the length limit to the desired position on the wave form preview.

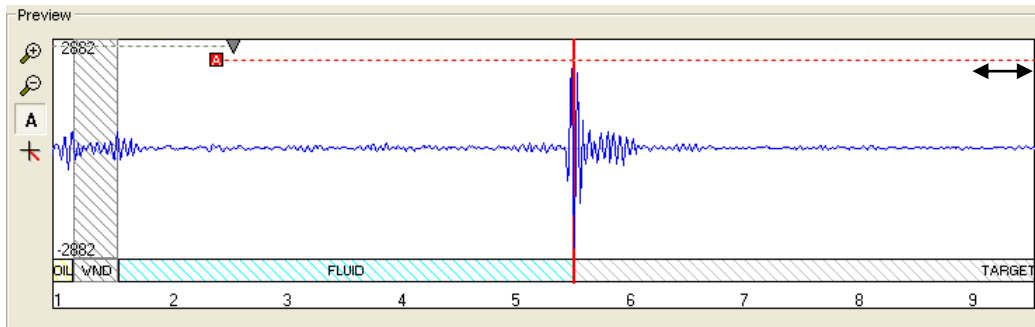

Figure 3-12 Toggling the Echo Gate Length between automatic and manual mode

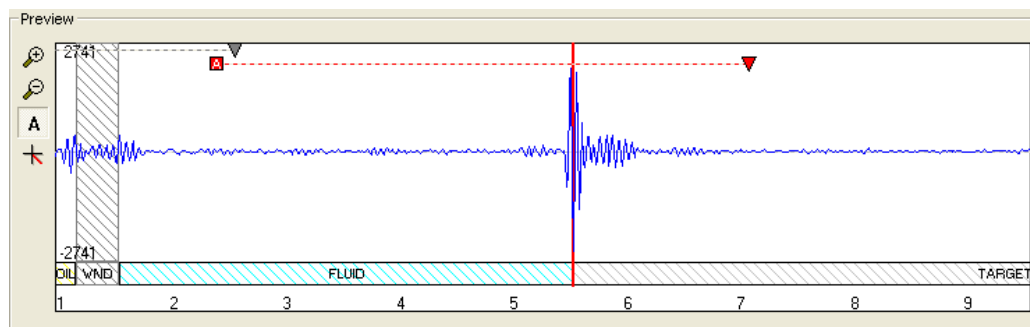

Figure 3-13 Echo Gate Length set in manual mode

To toggle the Echo Gate **Length** from manual to automatic mode, right click on the corresponding triangle symbol.

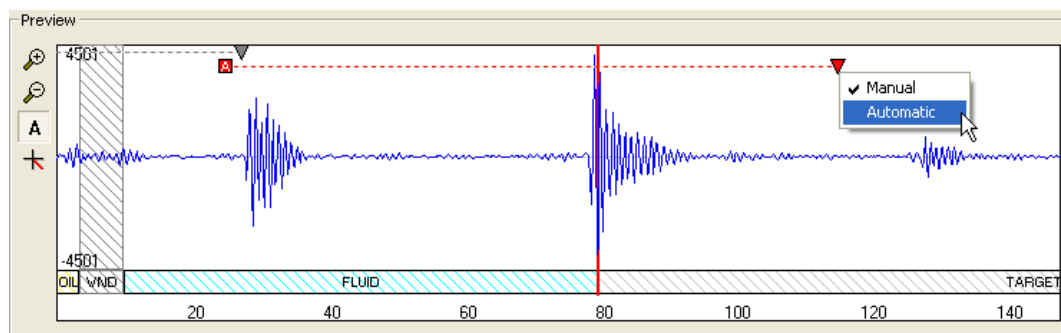

Figure 3-14 Toggling the Echo Length setting from manual to automatic

Data tab:

The screenshot shows the 'Data' tab of the Caliper software. It features two main sections: 'Record...' and 'Waveforms'. In the 'Record...' section, there is a checkbox labeled 'Target/Formation' which is checked. In the 'Waveforms' section, there are four radio button options: 'Don't record any waveform' (which is selected), 'Record acoustic single full waveform', 'Record acoustic multiple wavelets', and 'Record acoustic multiple interlaced wavelets'. There are also input fields for 'Echoes' and 'Waveforms'.

Figure 3-15 Data record options for the Open hole mode

The **“Target/Formation”** record option **must always be checked**. If unchecked, no acoustic image will be recorded.

For diagnostic purposes or advanced processing, the **“Waveforms”** record option can be activated.

- The **“Record acoustic single full waveform”** option record the complete ultrasonic waveform shown in the preview window in a single and predefined direction.
- The **“Record acoustic multiple wavelets”** option records the echo wavelets reflected on the borehole wall. The system records a maximum of 36 wavelets over the borehole circumference on each acoustic trace.

Note that recording the ultrasonic waveforms and wavelets will affect the telemetry performance and will slow down the logging speed significantly.

3.5.1.2 Behind PVC Mode

The **“Behind PVC”** mode is used in PVC cased boreholes. The main purpose is to log the borehole wall image located behind a PVC casing.

The algorithms implemented in the tool firmware detect and record all existing echoes on the ultrasonic waveforms. The detected echoes are then sorted and interpreted as a reflection from the casing or from the borehole wall (Figure 3-16).

Remind that for such application, the PVC casing must be properly centred in the borehole and the tool correctly centralised in the casing to obtain satisfactory results.

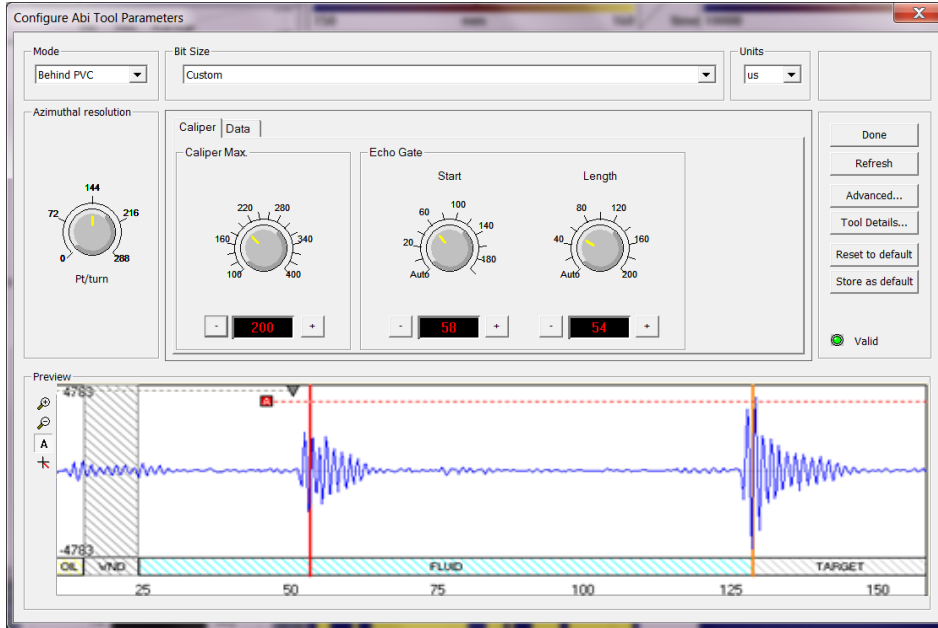

Figure 3-16 Behind PVC settings – automatic settings

The “Behind PVC” mode gives access to two main tabs – **Caliper** and **Data** - for configuring the record:

Caliper tab:

The caliper settings described in section 3.5.1.1 are applicable for the “Behind PVC” mode.

Mainly two major echoes are detected on the waveform preview. The first one is the reflected echo from the inner side of the casing. It is highlighted by the red vertical line. The second reflected echo, corresponding to the borehole wall, is highlighted by the orange vertical line.

Data tab:

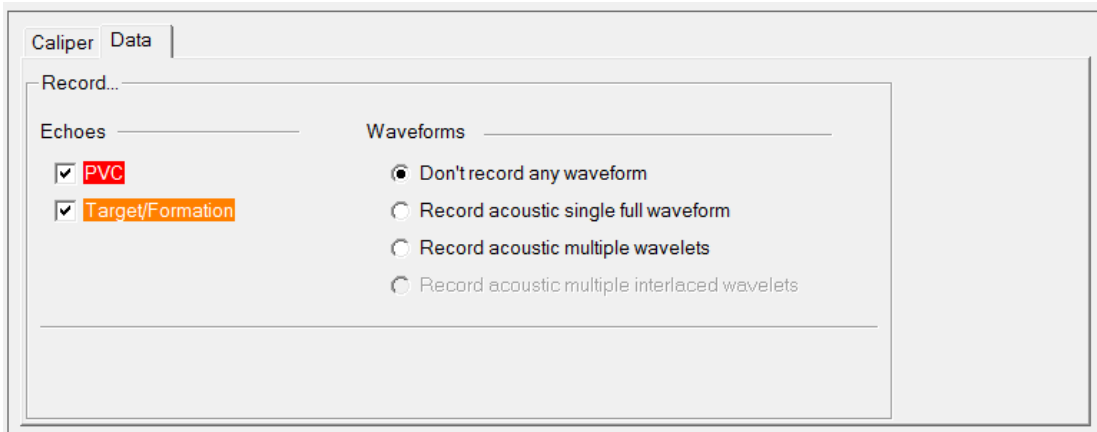

Figure 3-17 Data record options for the Behind PVC mode

By default, the system records both the PVC and the Target/Formation images.

The **“Target/Formation”** record **option must always be checked**. If unchecked, no acoustic image from the borehole wall will be recorded.

Option is given to the user to record or not the image of the inner face of the PVC casing. Recording the PVC image might be interesting to check the casing integrity or for looking at eventual encrustations.

For diagnostic purposes or advanced processing, the **“Waveforms”** record option can be activated.

Note that recording the ultrasonic waveforms and wavelets will affect the telemetry performance and will slow down the logging speed significantly.

3.5.1.3 Cased Hole Mode

The **Cased Hole** acquisition mode is used to perform casing thickness measurements in a steel casing or tubing.



Figure 3-18 Example of Cased hole settings

The operator will need to select from the dropdown casing list the nominal specifications of the casing under investigation (Figure 3-18).

When selecting a predefined **“Casing size”**, the system configures in an automatic way the most adequate tool settings – azimuthal resolution, caliper max, echo gate, thickness, echo gate length - for the casing external diameter and weight chosen.

User has also the choice to customize its own settings manually by adjusting the different knobs or interactively in the waveform preview window as described in a previous chapter.

Imperial or **metric units** can be used for displaying the waveform preview and for configuring the caliper - thickness settings.

Caliper tab:

The caliper settings described in section 3.5.1.1 are applicable for the “Cased hole” mode. Caliper settings must be adjusted for recording the echo reflected on the inner face of the steel casing.

Thickness tab:

From the thickness tab, the operator has the option to edit the internal (Low) and external (High) casing thickness dimensions manually for the record.

The Echo gate Length can be adjusted from this window or interactively from the wave form preview.

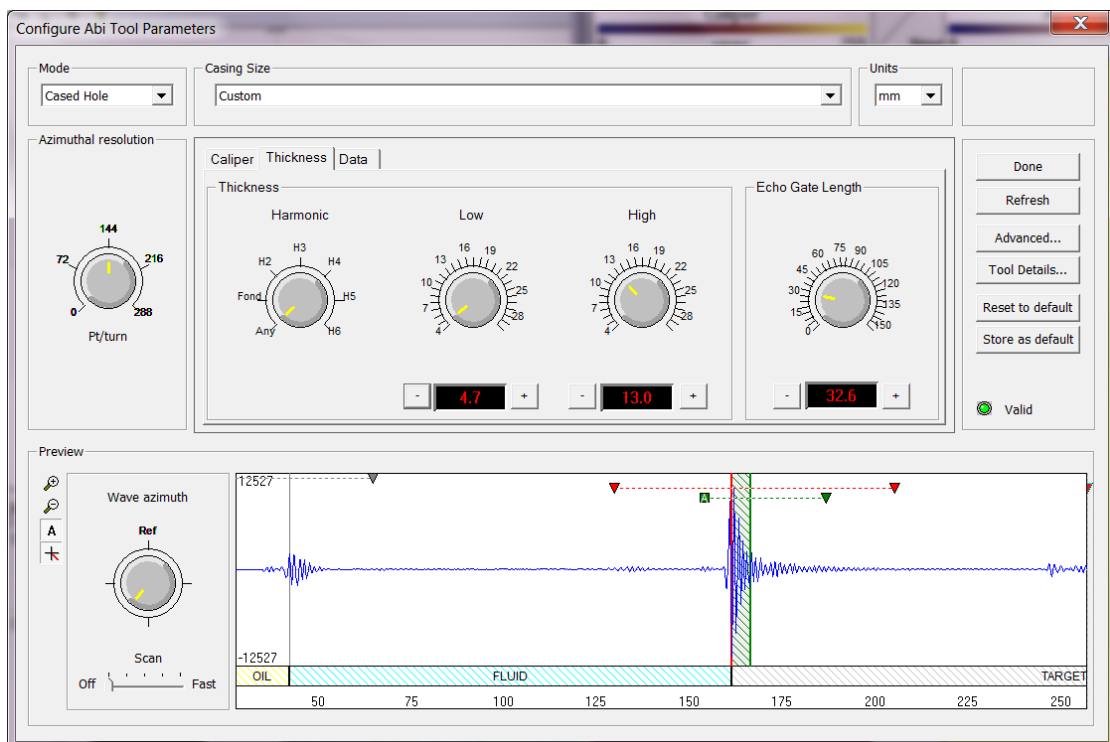

Figure 3-19 Thickness and Echo Gate Length settings

For cased hole application, in addition to the Acoustic Window and Echo Gates, a third gate - the **Thickness Echo Gate** (green dashed line – Figure 3-19) - is available for which only the end limit is user adjustable. Reduction of the gate length may be necessary if the ringing signal from the casing is superimposed by noise (e.g. multiples of the inner reflection) towards the end of the gate period.

The greyed - green hatched interval overlapping the recorded echo on the wave form preview is representing the casing thickness measured by the system for this specific ultrasonic trace and orientation.

The “**Harmonic**” knob controls the signal harmonic on which the processing algorithms will be applied. By default the “**Harmonic**” knob must stay on “**Any**”. Other “**Harmonic**” options are applicable for advanced users or developers only.

Data tab:

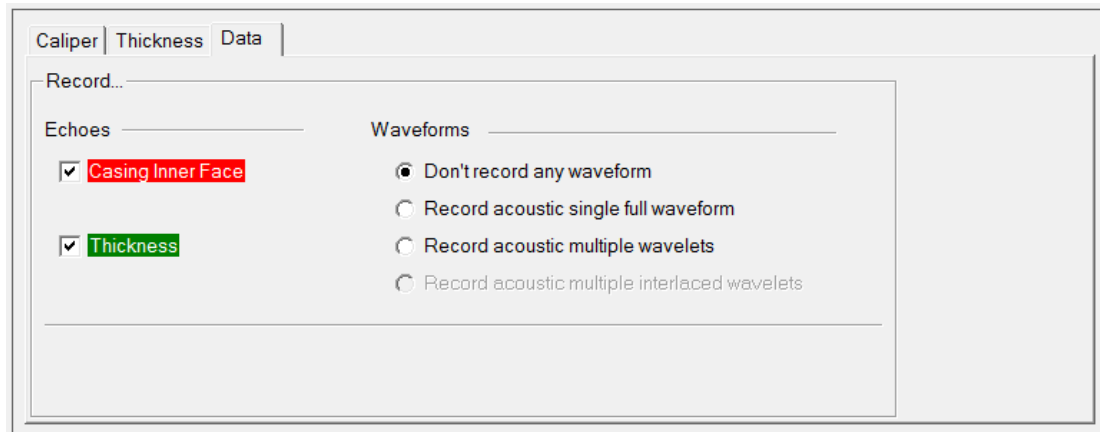

Figure 3-20 Data record options for the Cased hole mode

Option is given to the user to record or not the image of the inner face of the steel casing. Recording the casing inner face image is required for further internal caliper processing and for casing thickness/corrosion evaluation.

For diagnostic purposes or advanced processing, the “**Waveforms**” record option can be activated.

- The “**Record acoustic single full waveform**” option record the complete ultrasonic waveform shown in the preview window in a single and predefined direction.
- The “**Record acoustic multiple wavelets**” option records the echo wavelets reflected on the borehole wall. The system records a maximum of 36 wavelets over the borehole circumference for each acoustic trace.

Note that recording the ultrasonic waveforms and wavelets will affect the telemetry performance.

For cased hole application it is recommended to run the QL43 ABI in conjunction with the QL43 DDS (Downhole Data Storage sub). Recording the wavelets in downhole memory enables a significant increase of the logging speed and offers the option to perform post processing of the field data in the WellCAD Cased Hole Ultrasonic workspace.

3.5.2 Azimuthal resolution

The azimuthal resolution allows the operator to choose the number of points sampled per revolution of the focusing mirror. Sampling rates of 72, 144, 216 and 288 measured points per revolution are available.

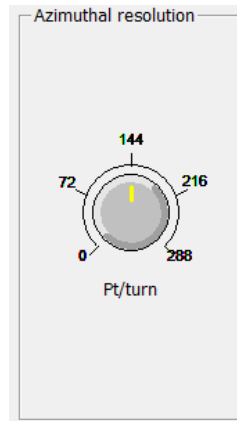

Figure 3-21 choice of azimuthal resolutions

The higher sampling rate can be used for better resolution in larger diameter boreholes but it might be less useful in small diameter hole as it would cause an overlap of sample points. The speed of rotation of the focusing mirror is directly linked to the azimuthal resolution and echo mode chosen.

3.5.3 Additional notes on the waveform preview

Beside the interactive settings of the echo gates, the waveform preview is offering other tools to enhance the display of the ultrasonic trace:

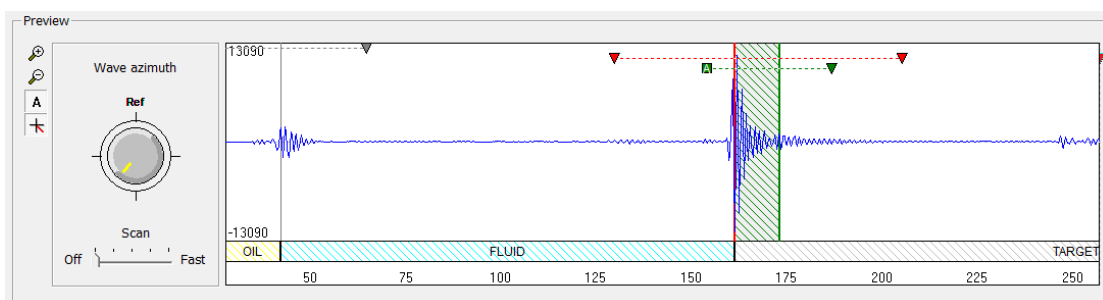

Figure 3-22 Display of the wave azimuth control knob and scan option



Zoom in the vertical scale of the echo amplitude



Zoom out the vertical scale of the echo amplitude

A

Set the vertical scale automatically with the best fit for the echo display

A



Display the wave azimuth control knob and scan option

The **Wave Azimuth** knob in the full waveform preview box (Figure 3-22) gives the possibility to display the ultrasonic wave train in a preferential direction other than the reference position of the mirror.

The preview of the full waveform of the received signal is generated at the position indicated by the **Wave Azimuth** control knob. By turning the control knob, a different position relative to the tool internal reference side can be chosen.

To turn on an **automatic scan** move the slider bar handle from the **Off** position towards **Fast**. In that case the azimuthal scan position will continuously change with the azimuthal step increasing if the slider position is set towards **Fast**.

3.5.4 Advanced Settings

By clicking on **Advanced** in the “Tool Parameters” dialog box (Figure 3-19) the operator can edit the “Fluid and Casing velocity” constants to convert the acoustic travel time from μsec to metric or imperial units. The default values are 1480 m/s for the fluid velocity and 5850 m/s for the steel velocity.

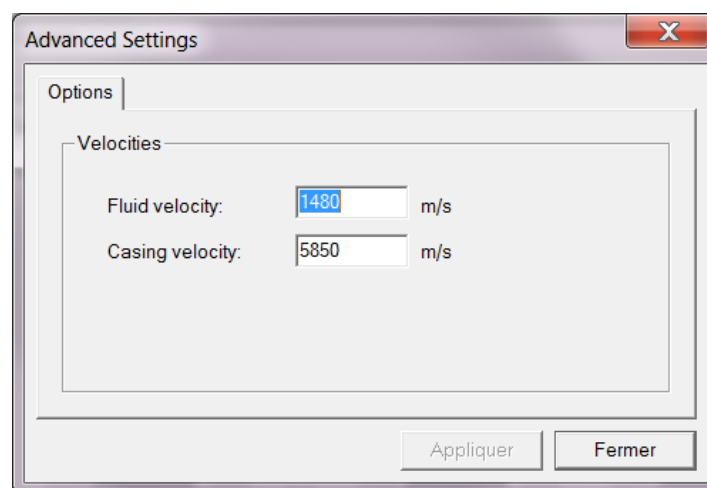
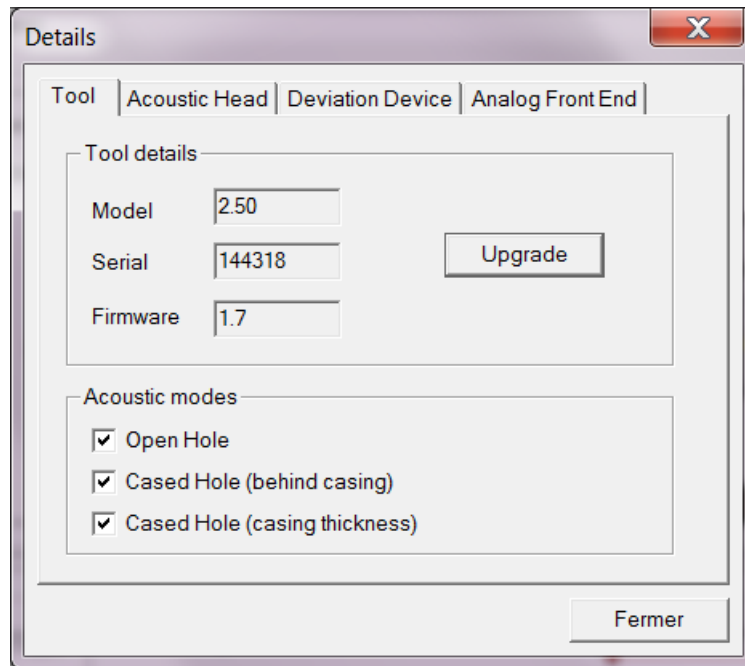

Figure 3-23 Advanced settings

3.5.5 Tool details

By clicking on the **Tool Details** button in the **Configure ABI Tool Parameters** dialog box four tabs (Figures 3-24 to 3-27) become available summarizing tool serial number, acoustic head details, deviation sensor model and analog front end. If necessary, newer tool firmware versions can be uploaded. The upgrade procedure will be explained in a later chapter.

Note: All the information displayed in the following dialog boxes can't be edited



The screenshot shows a 'Details' dialog box with a close button (X) in the top right corner. The 'Tool' tab is selected, and the 'Acoustic Head' sub-tab is active. The 'Tool details' section contains three input fields: 'Model' with the value '2.50', 'Serial' with '144318', and 'Firmware' with '1.7'. An 'Upgrade' button is positioned to the right of the 'Serial' field. The 'Acoustic modes' section has three checked checkboxes: 'Open Hole', 'Cased Hole (behind casing)', and 'Cased Hole (casing thickness)'. A 'Fermer' button is located at the bottom right of the dialog.

Field	Value
Model	2.50
Serial	144318
Firmware	1.7

Acoustic modes:

- Open Hole
- Cased Hole (behind casing)
- Cased Hole (casing thickness)

Figure 3-24 Tool details

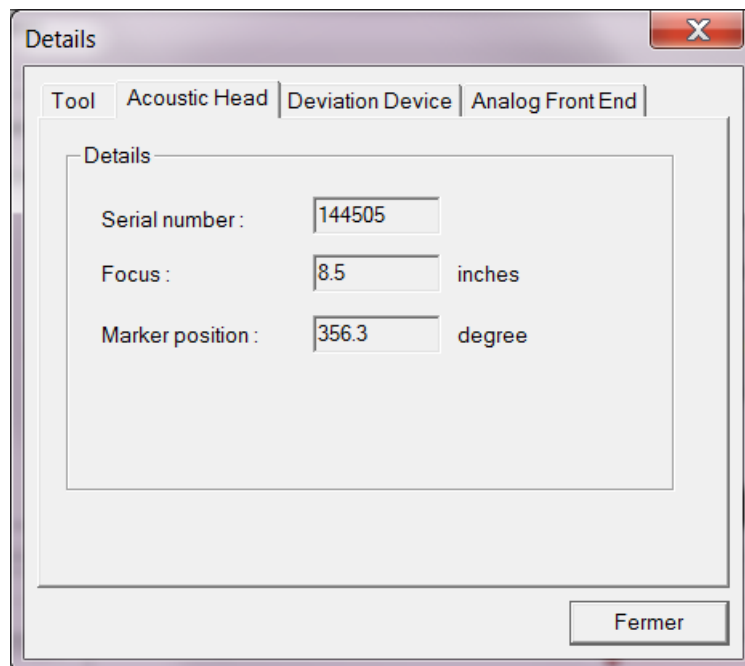

The screenshot shows the same 'Details' dialog box, but with the 'Acoustic Head' sub-tab selected. The 'Details' section contains three input fields: 'Serial number' with '144505', 'Focus' with '8.5' inches, and 'Marker position' with '356.3' degree. A 'Fermer' button is located at the bottom right of the dialog.

Field	Value	Unit
Serial number	144505	
Focus	8.5	inches
Marker position	356.3	degree

Figure 3-25 Acoustic head details

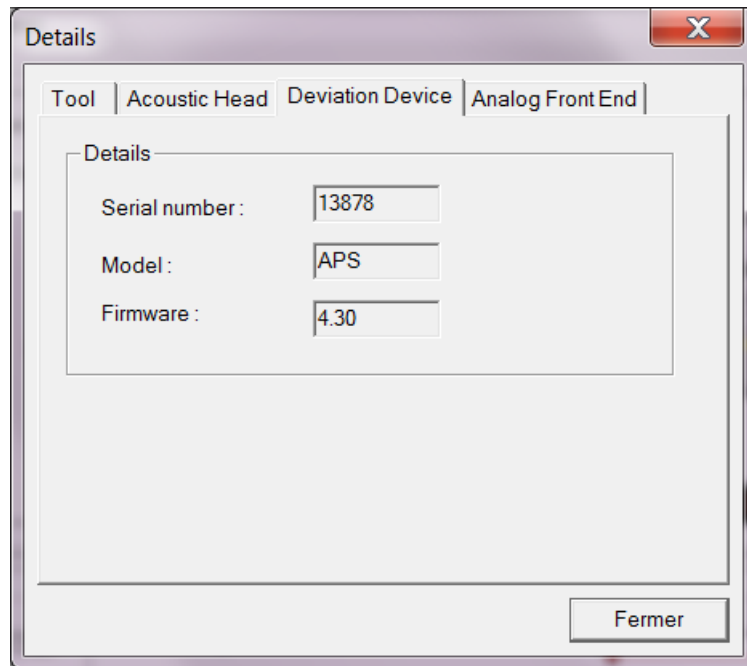

Figure 3-26 Deviation sensor details

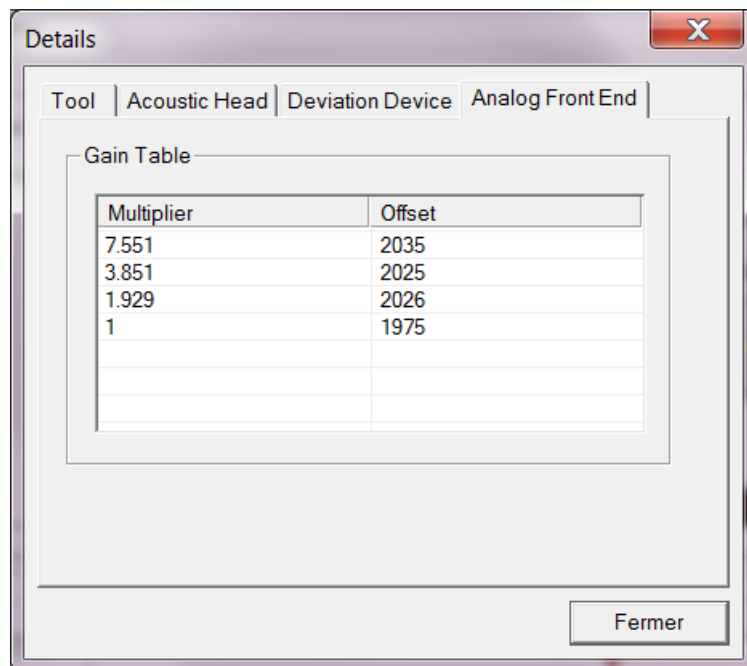

Figure 3-27 Analog Front End

3.6 Recorded Parameters and Browsers

3.6.1 Recorded parameters

The following data channels will be recorded by the tool:

TravelTime (1 st echo):	Two Way Traveltime 1 st echo - μ sec
Amplitude (1 st echo):	Amplitude 1 st echo (NM = North Magnetic, HS = High Side)
TravelTime (2 nd echo):	Two Way Traveltime 2 nd echo (behind PVC) - μ sec
Amplitude (2 nd echo):	Amplitude 2 nd echo (behind PVC) (NM = North Magnetic, HS = High Side)
ThicknessTTime:	Two Way Traveltime within casing - μ sec
Score:	Quality Index for thickness signal detection
CADI:	Cement Attenuation Decay Index
Azimuth:	Azimuth from Magnetic North – deg
Tilt:	Inclination from verticality – deg
RBR:	Orientation angle to High Side – deg
Roll:	Tool relative bearing calculated from accelerometers – deg
Mroll:	Tool relative bearing calculated from magnetometers – deg
Magn.Field:	Magnetic field surrounding the borehole - μ T
Gravity:	Absolute value of the Earth gravity – g
Mx:	Calibrated magnetic field – x component - μ T
My:	Calibrated magnetic field – y component - μ T
Mz:	Calibrated magnetic field – z component - μ T
Ax:	Calibrated gravity – x component - g
Ay:	Calibrated gravity – y component - g
Az:	Calibrated gravity – z component - g
WndTime:	Two way travel time of acoustic window reflection – μ sec
WndAmpl:	Amplitude of acoustic window reflection
RThead:	Resistance sensor for acoustic head temp. - ohm
RTmotor:	Resistance sensor for motor temperature - ohm
VT CPU:	Sensor reading for CPU board temp. - volt
T Head:	Temperature of the borehole fluid - °C
T Motor:	Motor temperature - °C
T CPU:	Temperature recorded on CPU board - °C
T DEV:	Temperature inside the deviation sensor - °C
MotSpeed:	Motor - Speed of rotation – rps
Motor Status:	Diagnostic code (0 = No Sync, 1 = Valid)
Motor Period:	Time for a single revolution – sec

3.6.2 MChNum Browser Window

Figure 3-28 shows a typical example of the numerical values displayed in the MChNum browser window during logging.

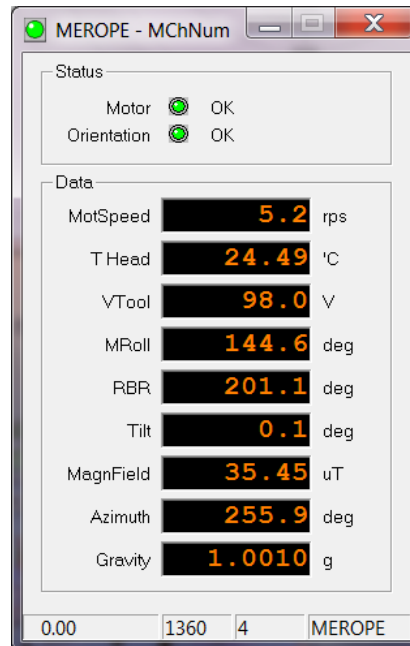

Figure 3-28 Multi Channel Browser for Numerical Data (MChNum)

Right click on the MChNum browser title and select **Display Options** to add / remove channels.

3.6.3 Surface Image Browser Window (AbiSurfacelmg)

The system returns an unwrapped image of the borehole wall based on the caliper and amplitude of the recorded acoustic signal (Figure 3-29). The left column shows the caliper image and the right column the amplitude image.

These images consist of a succession of variable density colors. By double clicking on the log titles Minimum and Maximum scale values may be adjusted to enhance areas of interest.

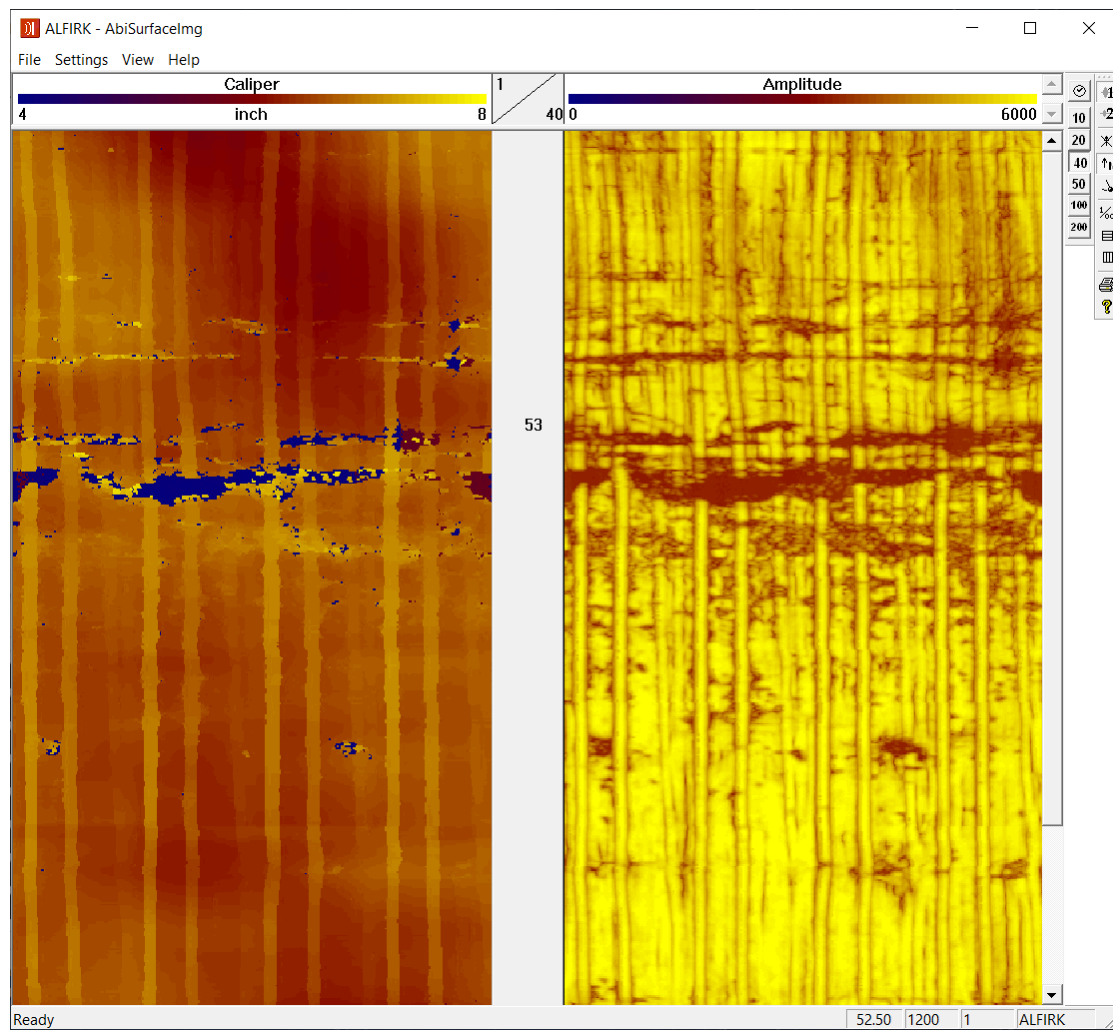





Figure 3-29 QL43 ABI Surface Image browser window

Note that the displayed units for the caliper log can be converted to either metric or imperial units via the menu bar's **Settings** option or by double clicking on the log title.

Image orientation:

-  Image is non-oriented
-  Orient image to magnetic North
-  Orient image to High Side of the tool

There are two modes of tool data orientation: orientation to High Side and orientation to North (Figure 3-30). Orientation to High Side is used in inclined boreholes when magnetic data is unavailable (for example in a cased hole).

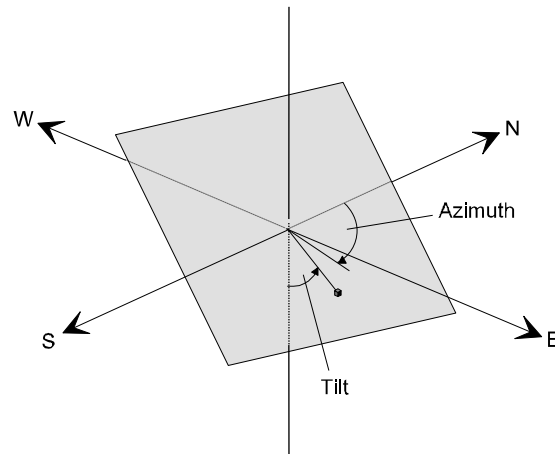

Figure 3-30 Orientation to Magnetic North

Vertical scales and grids:

- 10 Depth mode display and pre-defined depth scales
- 20
- 40
- 50
- 1/100 Operator defined depth scales, interval spacings and settings
- Time mode display

3.6.4 CADI Image Browser Window (AbiCadimg)

In Cased Hole Mode, the CADI browser displays on the left column an unwrapped color coded image of the casing *thickness* processed by the system (Figure 3-31). The right column is a color-coded image of the *score*. The score is a *quality index* on the thickness measurement. In a general way, high score values mean high reliability of the thickness measurement and the reverse.

The CADI image log displayed in the middle of the window represents a qualitative index related to the cement bonding. A high CADI indicates a good cementation, a low CADI indicates a poor cementation. CADI stands for Cement Attenuation Decay Index. As CADI is a non-calibrated qualitative index, it needs to be interpreted by the user in a semi-qualitative way similar to conventional CBL.

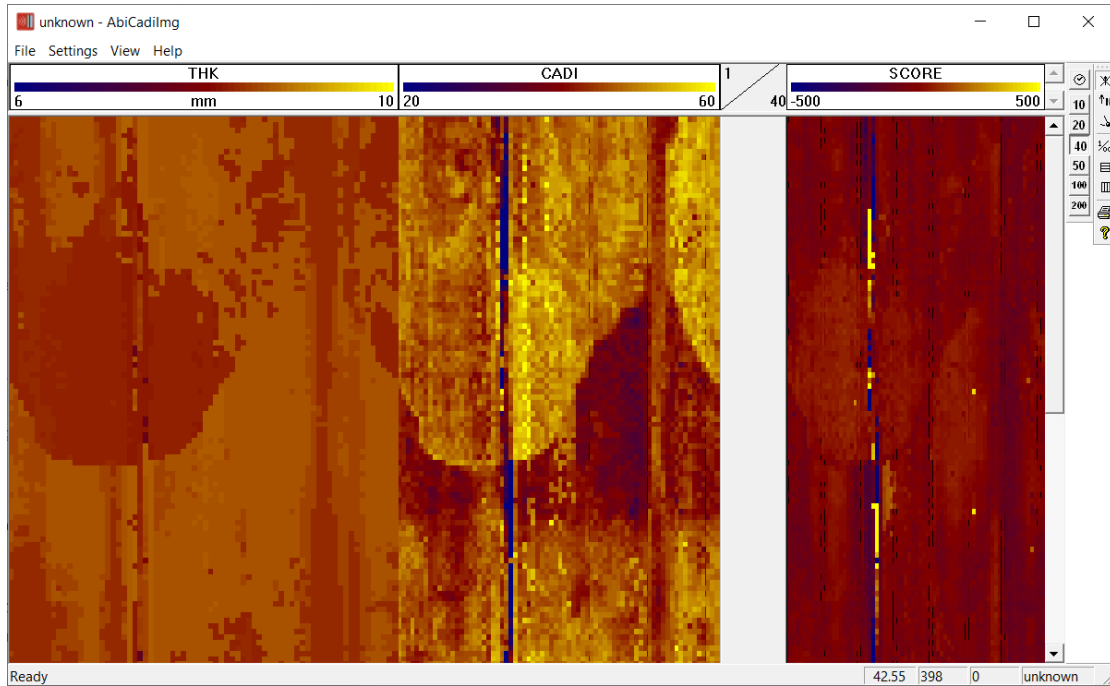

Figure 3-31 QL43 ABI Thickness Image

As for the Surface image browser, scales and units of the displayed parameters can be adjusted by double clicking on the log title or from the **Settings** option of the menu bar.

3.6.5 Caliper Browser Window (AbiCaliper)

Caliper browser - Open Hole Mode

The Open Hole caliper view (Figure 3-32) shows in real-time a cross-section of the acoustic caliper. Scaling, concentric gridding and displayed units are adjustable from the tool bar "Settings" option.

The black circle shows the external limit of the acoustic window.

The red circle is the cross section of the acoustic caliper corresponding to the main reflector detected by the system (borehole wall or inner surface of a casing).

As for the image browsers, the caliper view can be oriented to Magnetic North, High side or displayed without orientation.

During the acquisition, it is possible to centralize the caliper cross section to remove the effect of decentralization of the tool in the borehole.

Clicking the symbol  can do this.

Statistical caliper figures (Min, Max, Average) are displayed on the left side of the dialog box.

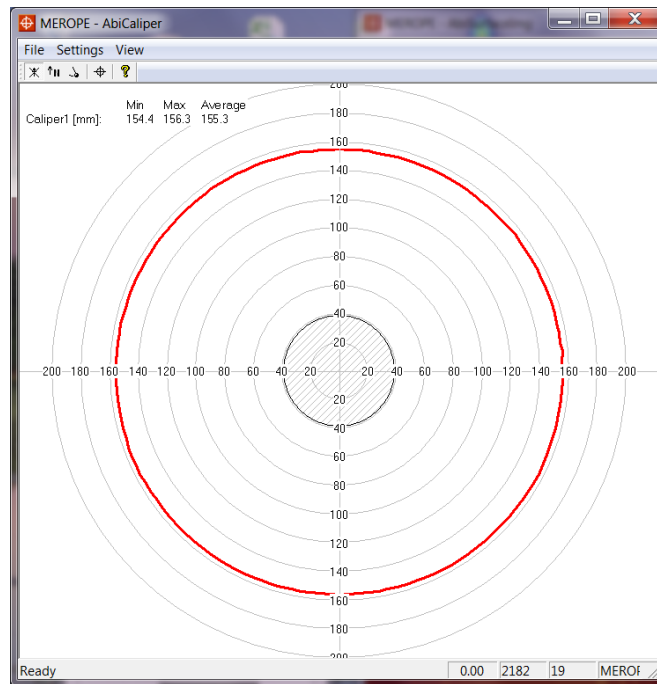

Figure 3-32 QL43 ABI Caliper – Open Hole Mode

Caliper browser - Cased Hole Mode

Cross sections of both of the inner (red circle) and outer (green circle) surface of the casing are shown in this browser (Figure 3-33), giving a good visualization of the casing thickness in real-time. The space between the 2 circles is filled with the corresponding color coded score values.

Orientation, scaling, concentric gridding and displayed units are adjustable from the menu bar's **Settings** option.

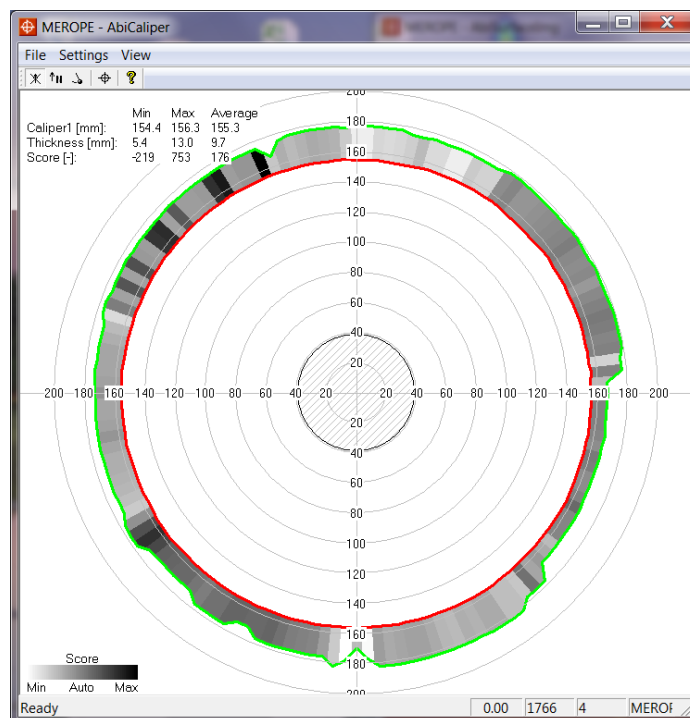

Figure 3-33 QL43 ABI Caliper – Cased Hole Mode

3.6.6 Wavelet Browser Window (AbiWavelet)

The “**Wavelet browser**” displays the echo wavelets recorded by the system. Note that wavelets are only visible when the “**Record acoustic multiple wavelets**” is activated in the “**Configure Tool Parameters**” dialog box. The main purpose of this display is to check that the system is recording wavelets. The recorded wavelets are used for data post-processing.

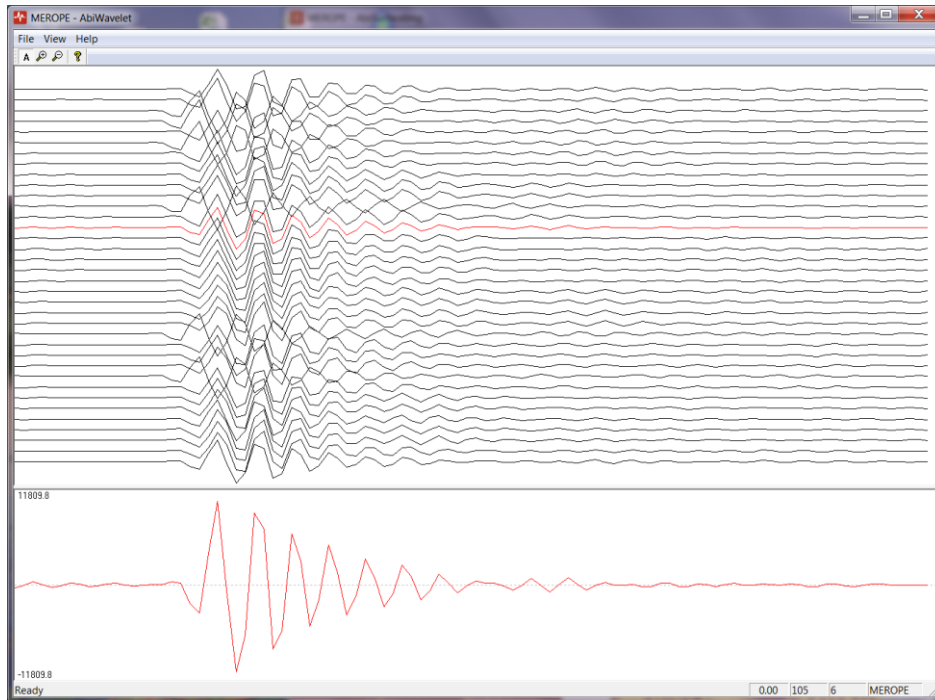

Figure 3-34 QL43 ABI Wavelet

4 Performance Check & Calibration

4.1 Mirror rotation

Direction of motor rotation is **clockwise viewed from top of tool** (Figure 4-1):

Placing 2 fingers² on the acoustic window may check mirror rotation. In time mode, record the 2 finger traces shown³ on the Abi surface browser. Remove your right finger from the acoustic window; the corresponding right finger trace on the Abi surface image should disappear.

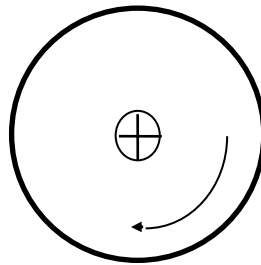

Figure 4-1 Direction of mirror rotation

4.2 Functionality test of the deviation system

4.2.1 Functionality test

The QL43 ABI's deviation system is factory calibrated and does not require further calibration.

The functionality tests subsequently described have to be done to check that the tool is giving the correct deviation outputs:

To verify inclination at 0° and 90°, position the probe vertical (acoustic head pointing down) for 0° inclination and horizontal for 90° inclination. Note that uphole measurement is possible with the APS544 deviation system as it includes 3 accelerometers. In uphole, the inclination will be between 90° and 180° (probe vertical, acoustic head pointing up).

To verify azimuth accuracy, a good compass and an area free of magnetic materials must be used. Use a compass to orient North with the probe horizontal and verify that the azimuth reading is $0^\circ \pm 1^\circ$. Repeat the procedure for East, South and West directions.

4.2.2 Rolling test – azimuth and tilt check

Azimuth and tilt could be tested by rotating the tool about its long axis while maintaining both a constant inclination to the vertical, say 15°, and a fixed azimuth. The data imported into WellCAD should show a deviation of the azimuth less than the limit of $\pm 2.5^\circ$ and a deviation of the tilt less than the limit $\pm 0.5^\circ$.

² Wet your fingers first for a better coupling

³ Adjust the amplitude scale to enhance the finger traces

5 Maintenance

Warning: Removing the electronic chassis from pressure housing without prior consultation with ALT will void the tool warranty.

The QL43 ABI televiewer is a delicate instrument and should be treated with care at all times. Excessive shock or extreme temperatures should be avoided and the tool should always be transported in its transport case or a similarly cushioned enclosure. Never support the tool on the acoustic head. Experience shows that with attention to these points the QL43 ABI will give several years fault free operation.

The QL43 ABI televiewer separates into four basic parts

- The tool head adapter
- The pressure housing
- The electronic chassis
- The acoustic head.

Should it become necessary to open the tool, the tool parts must be separated in the following sequence:

1. Remove the tool head adapter
2. Remove the acoustic head
3. Remove the pressure housing

Disassembly of the electronic chassis from the pressure housing should never be attempted in the field.

Note: A special extractor is required to remove the electronic chassis from the pressure housing.

5.1 Tool Head Adapter

The tool head adapter provides the connection between wireline cable head and chassis electronics and can be provided to suit 7 conductors, 4 conductors, mono or special wireline configurations. The adapter is fixed by the means of a bronze-beryllium threaded quick link mounted on the pressure housing section. To remove the tool head adapter, use the correct C spanners provided with the tool - see picture below (Figure 5-1). Looking towards the tool head, unscrew the bronze-beryllium ring clockwise.



Figure 5-1 Removing the tool head

The wireline cable head socket and tool head adapter connector pins should be checked for cleanliness before each use of the tool. The pin inserts, whether 4 or 7 pin, have a locating mark indicating WL1 or A that should line up with the slot mating with the cable head.

Check O-Ring seals and apply silicon grease before re-assembly. Silicon grease of a similar type to RS Components Ref 494-124 is suitable for this and other O-Ring seals.

(Rem: O-Ring reference for tool head is AS215 26,57 x 3,53 Viton Shore 90)

5.2 Acoustic head

Warning: The televiewer head is extremely delicate and must be treated gently at all times. Any laterally applied force on the end of the head is liable to cause damage!

The acoustic head must be cleaned after each use specially the pressure balancing system. The level of maintenance will depend on the type of operation and the time between maintenances. Two levels of maintenance are recommended. The following guidelines will help you to keep the instrument in good operational conditions:

Level 1 maintenance:

- after each operation

Level 2 maintenance:

- after an operation in a thick fluid charged with solid particles
- or after 10 maintenances level 1
- or after 2 months and less than 10 maintenances level 1
- or if the position of the piston is out of specifications (see Level 1 maintenance).

5.2.1.1 Removing the QL43 ABI acoustic head

The acoustic head is attached to the tool cartridge by the means of a bronze-beryllium threaded quick link mounted on the head itself- see picture below:

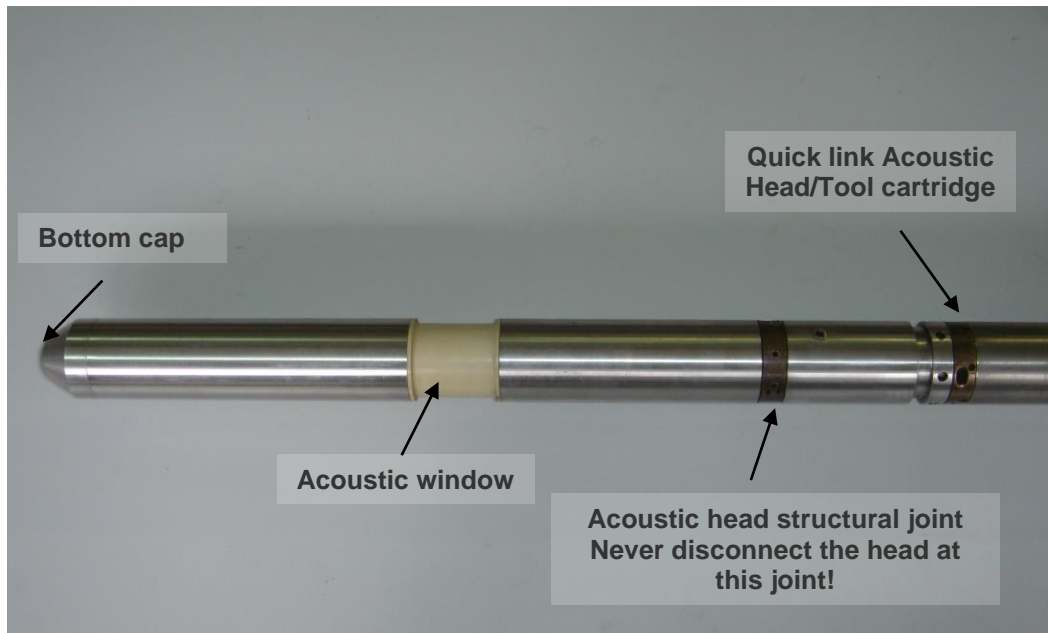

Figure 5-2 QL43 ABI Acoustic Head

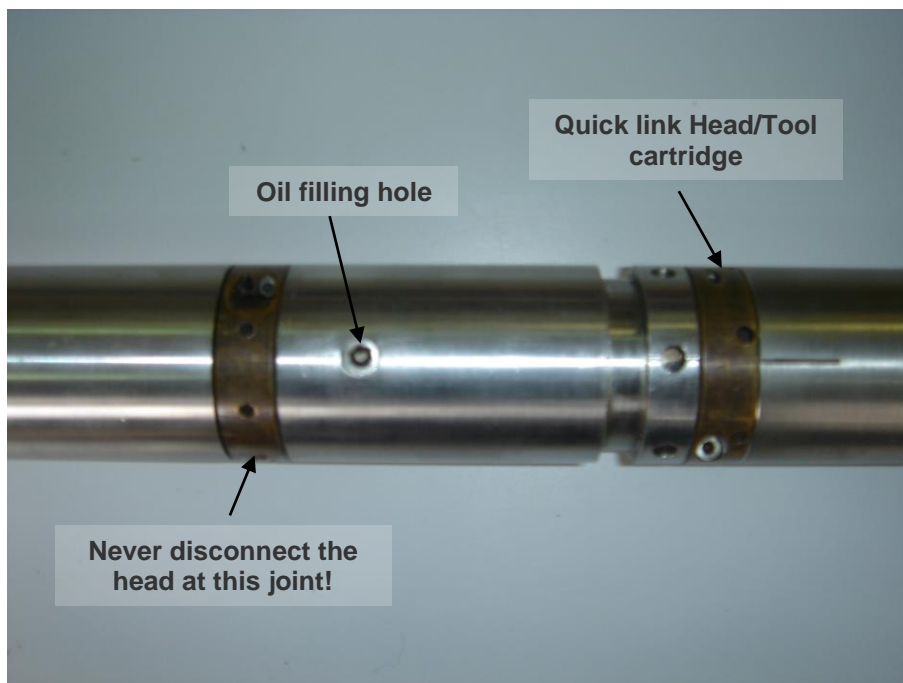

Figure 5-3 Acoustic head joints

To remove the acoustic head from the tool cartridge, use the correct C spanners provided with the tool.

Looking towards the bottom of the tool, unscrew the bronze-beryllium ring clockwise.



Figure 5-4 removing the acoustic head

Note: Never attempt disconnection of the acoustic head at the structural joint as this will result in oil leakage and irrevocable damage. Only experienced personnel should be allowed to carry out maintenance of the acoustic head.

Check O-Ring seals and apply silicon grease before re-assembly. Silicon grease of a similar type to RS Components Ref 494-124 is suitable for this and other O-Ring seals.
(Rem: O-Ring reference for acoustic head quick link is: AS215 26,57 x 3,53 Viton Shore 90)

5.2.2 Level 1 maintenance

WHEN?

- After each operation.

5.2.2.1 Cleaning the acoustic head bottom section

Pressure compensation in the acoustic head is provided by a piston. The piston is located inside the housing below the acoustic window. To ensure that the piston can move freely in its housing, it is recommended to clean the bottom section after each logging job.

Warning: Failure to clean the bottom section may cause irrevocable damage to the tool acoustic head!

To clean the piston section, unscrew the acoustic head bottom cap. Remove the spring inside. Clean with a soft rag the inside of the housing. Verify that the hole drilled at the center of the bottom cap is not plugged with dirt.



Figure 5-5 Cleaning the bottom section



Figure 5-6 Piston and cylinder viewed from tool bottom

Verify the position of the piston as follow:

The distance between the end face of the cylinder and the lower part of the piston should be

- 42mm (+/-2mm) for the **QL43 ABI HEAD OHCO-L** (Short window)
- 45mm (+/-2mm) for the **QL43 ABI HEAD CO-S and CO-XXS** (Long window)

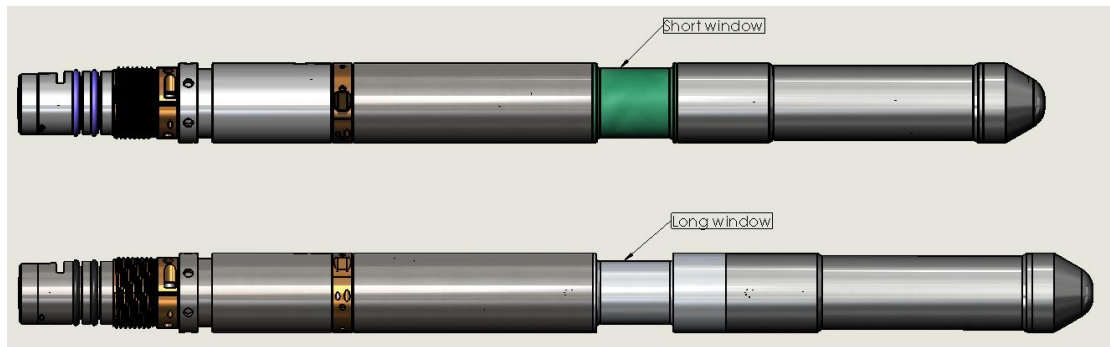

Figure 5-7 Short and long window heads

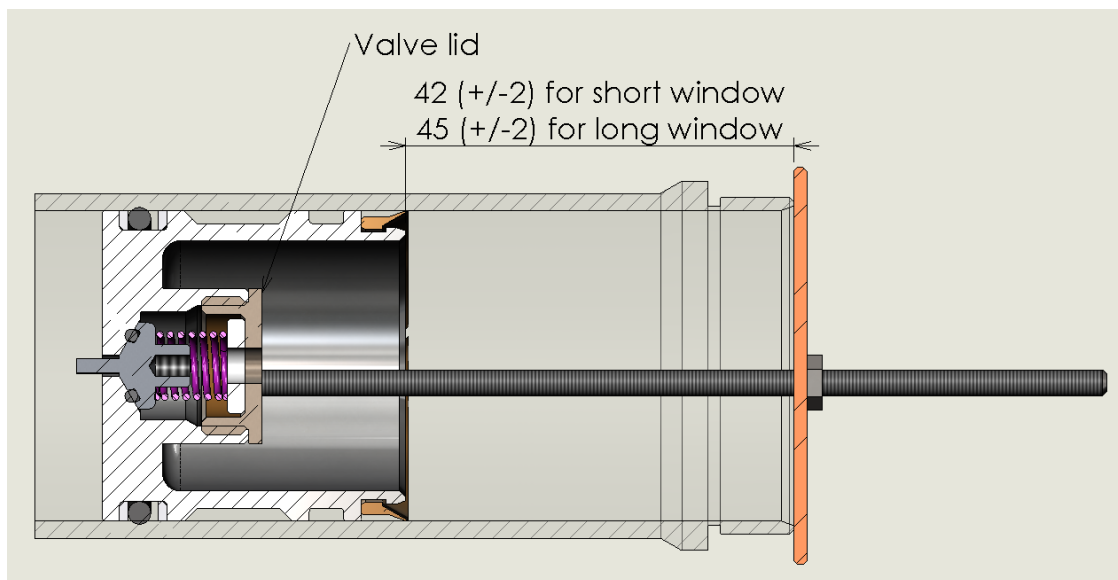
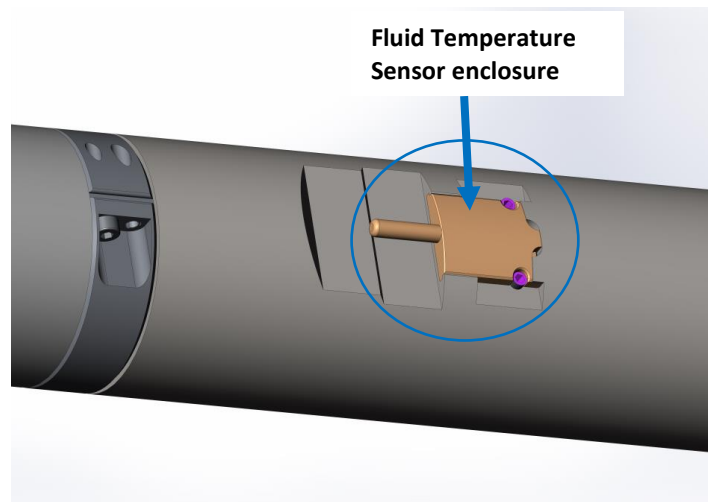

Figure 5-8 Position of the piston

If the position of the piston is out of the specifications, a level 2 maintenance has to be applied.

5.2.2.2 Cleaning the Fluid Temperature sensor

The Fluid Temperature Sensor enclosure must be cleaned after each tool operation to prevent any corrosion of the brass enclosure when exposed to corrosive fluids. Use a tooth brush and mild soap to remove the dirt and grits lodged around the sensor. Rinse with clear water once the dirt is removed.



5.2.2.3 Quik Link (QL) mechanical joints

- Remove water, water droplets and dirt from QL mechanical joints and Orings grooves. Once cleaned, grease the Orings for the next operation.
- Check whether the threaded ring rotates freely. Clean it and add grease if necessary.

5.2.3 Level 2 maintenance





WHEN?

- after an operation in a thick fluid charged with solid particles
- or after 10 maintenances level 1
- or after 2 month and less than 10 maintenances level 1
- or if the position of the piston is out of specifications (see Level 1 maintenance)

Spares:

Description	Quantity
Shell Morlina 5, 1liter	1liter
Silicon grease	1 tube
Oring AS123-V-75	1
Back up ring AS124	2
Oring AS025-V-75	1

Necessary equipment:

	C spanners
	Threaded rods M3 with nuts. plate (ref.:TOOL180014)
	ABI43 oil filler (ref.: TOOL18000) O Ring Viton 2.2x1.6 Viton Shore 70
	Refilling setup with a vacuum pump
	Allen keys

Level 2 maintenance:

1. Apply a level 1 maintenance
2. Open the head according to 5.2.4
3. Clean the piston according to 5.2.5
4. Replace the orings (see head schematic in 5.2.6)
5. Reassemble and fill with oil according to 5.2.6

5.2.4 Removing oil from the head

Place the acoustic head on suitable supports with a receptacle for the oil beneath. Unscrew the oil plug (Figure 5-9). Unscrew the cylinder located below the acoustic head window and let oil flow out of the head. The oil flows out through small holes located on the transducer support. Check the O-Ring seal situated on the top of the window.

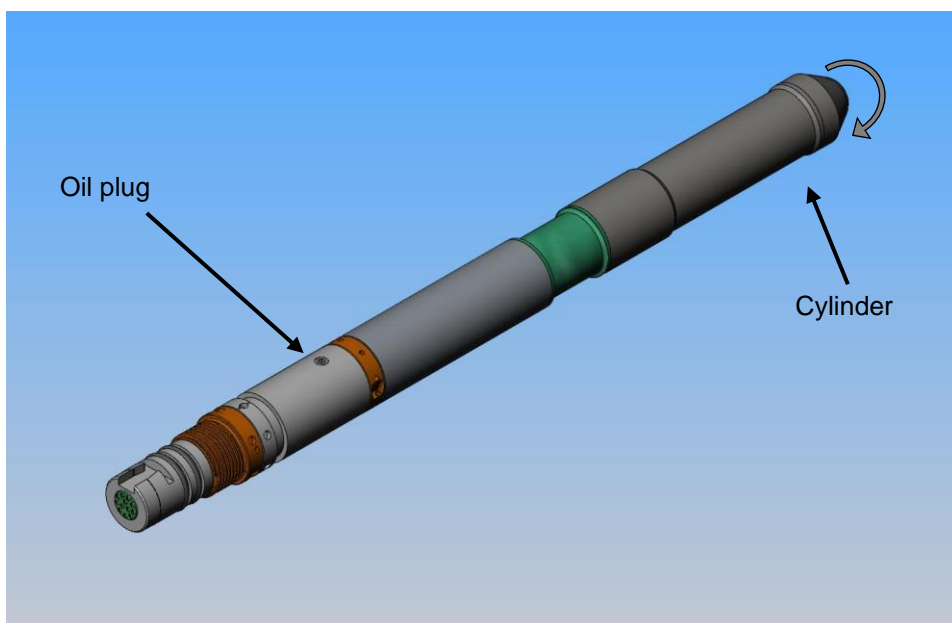

Figure 5-9 QL43 ABI acoustic head

Warning: Be careful the transducer is extremely fragile!



Figure 5-10 Cylinder



Figure 5-11 Head Without cylinder



Figure 5-12 Holes located on the tx holder

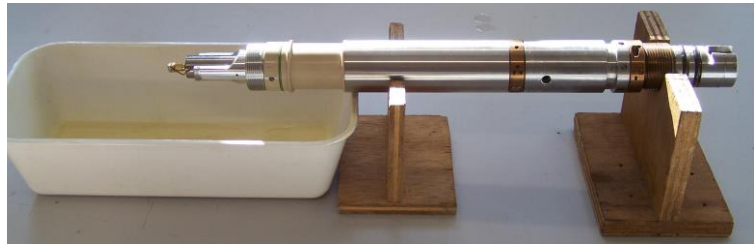

Figure 5-13 Acoustic head placed in draining position

5.2.5 Piston cleaning



Figure 5-14

Arming yourself with the QL43 Oil Refilling Kit (TOOL18021) , pass the two M3 threaded rods with nuts, as shown above, through the plate and screw them into the tapped holes provided in the end of the valve support.

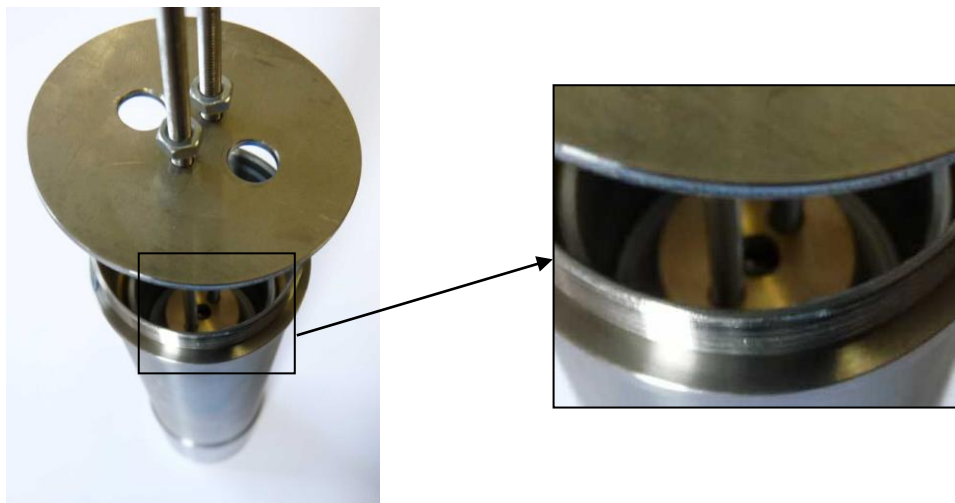

Figure 5-15

Extract the piston from the cylinder while paying attention to the scraper that is both sharp edged and fragile.

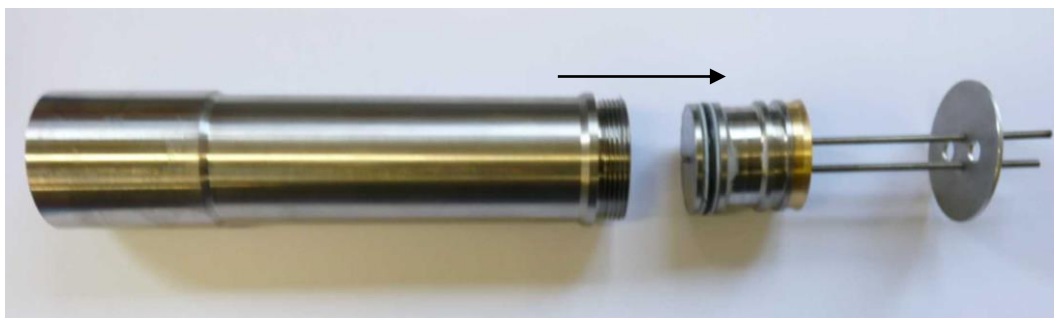

Figure 5-16

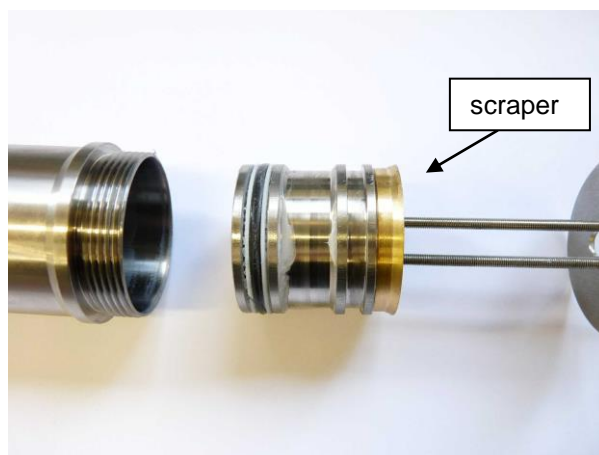

Figure 5-17

At this stage check the condition of the piston O-ring and its two backup rings (replace them if necessary), clean these parts and re-grease them. If the scraper is encrusted, carefully lift it off the piston and clean well. (Always pay particular attention not to damage this part during removal and replacement). Mud and deposits on the piston itself can be cleaned using a stiff brush - a toothbrush will do - and a suitable solvent.



Figure 5-18

To inspect and clean the pressure release system it is necessary to unscrew the valve support by means of the two threaded rods. Long nose pliers may be used to grip and turn the threaded rods while holding the piston by hand.



Figure 5-19

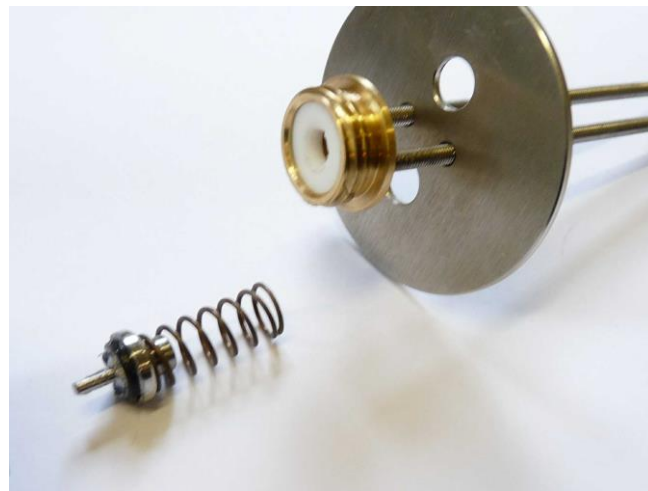

Figure 5-20

Clean all the pieces well, and inspect the valve O-ring. Be careful not to lose the white washer that is free in the assembly.

For reassembly: Thread a third M3 rod through the centre of the valve support, put the white washer in place followed by the spring, and screw the valve onto the rod. Charge the O-ring with grease. With the two outer M3 rods in place screw the assembly back into the piston. No fixing agent should be used and the valve support should be tightened until the lower face firmly abuts the piston and is locked but not over tight.



Figure 5-21



Figure 5-22



Figure 5-23



Figure 5-24

Clean the piston sleeve with a soft cloth, and if the thread is dirty use a small brush. O-ring and backups having been cleaned, inspected and re-greased, re-mount the scraper on the piston, fix the two M3 rods together with the plate, grease the inner entry face of the sleeve and carefully introduce the piston while paying attention to the insertion of the backup rings. Test the correct placement by moving the piston back and forth (the displacement force should be 15N +/-3N).



Figure 5-25

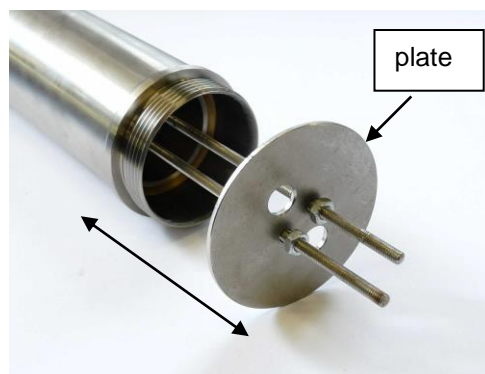

Figure 5-26

5.2.6 Refilling oil

Fixing the piston

Replace the housing cylinder.

Pass the threaded rods through the plate holes and screw them into the tapped holes in the outer face of the piston.

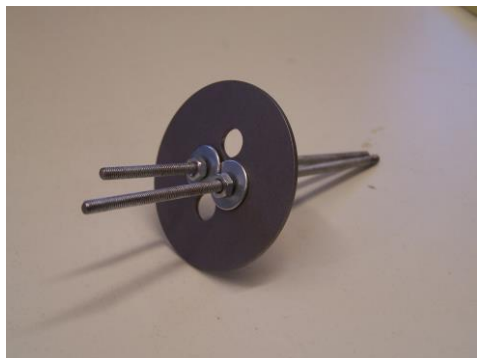

Rods on plate



Piston and piston housing viewed from the head bottom

Figure 5-27

The nuts on the rods are adjusted to set the distance between the plate against the end of the cylinder and the face of the piston.

Fixing the position of the piston is necessary to prevent it being drawn into its innermost position in the housing that corresponds to a maximum compression during the application of a vacuum in the filling process for the head.

The position of the piston depends on the type of the head.



Figure 5-28

Rods and plate fixed on the cylinder

Distances between the end face of the cylinder and the higher part of the piston are as follows:

- 42mm (+/-2mm) for the **QL43 ABI HEAD OHCO-L** (Short window)
- 45mm (+/-2mm) for the **QL43 ABI HEAD CO-S and CO-XXS** (Long window)

Over tightening the nuts on the rods can change the position of the piston.

Fixing the QL43 ABI Oil filler

First fix an O-Ring on the oil filler.

(Rem.: The O-Ring reference for oil filler is 2.2x1.6 Viton Shore 70)



Oil filler and O-Ring Viton 2.2x1.6 mm



O-Ring set on the oil filler

Figure 5-29

Then after having greased the oil filler screw it in the oil filling hole and fix the vacuum pump tube on it.



Oil filler screwed in the oil filling hole



Vacuum pump tube fixed on the oil filler screw

Figure 5-30

Refilling oil

To refill the acoustic head with new oil the ALT Oil Filling Unit is required (Figure 5-31). Refer to the Oil Filling Unit manual for the description of the complete procedure.



Figure 5-31 ALT Oil Filling Unit

5.2.7 Replacing the Fluid Temperature Sensor enclosure O’ring

- Unscrew the two hex screws from the brass enclosure
- With a thin flat screw driver push the brass enclosure laterally and lift it up gently as per the picture below
- With a pair of tweezers disconnect the PT100 temperature sensor and its enclosure by pinching the flexible metallic lamina from the connector socket
- Remove the old o’ring and replace with a new one (reference **AS012-V-75**: Oring 9.25 x 1.78 75°)
- Proceed with the reassembly of the sensor enclosure on the acoustic head

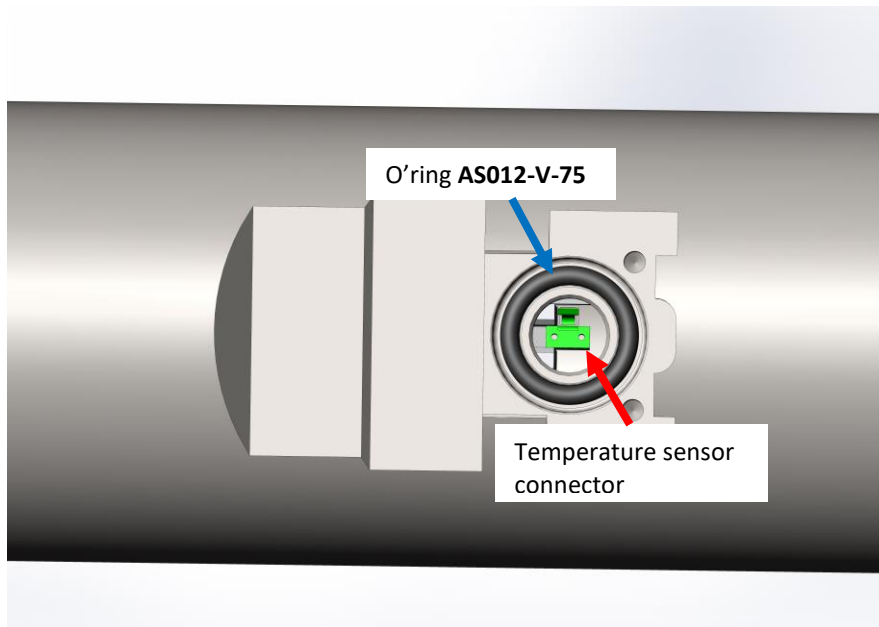
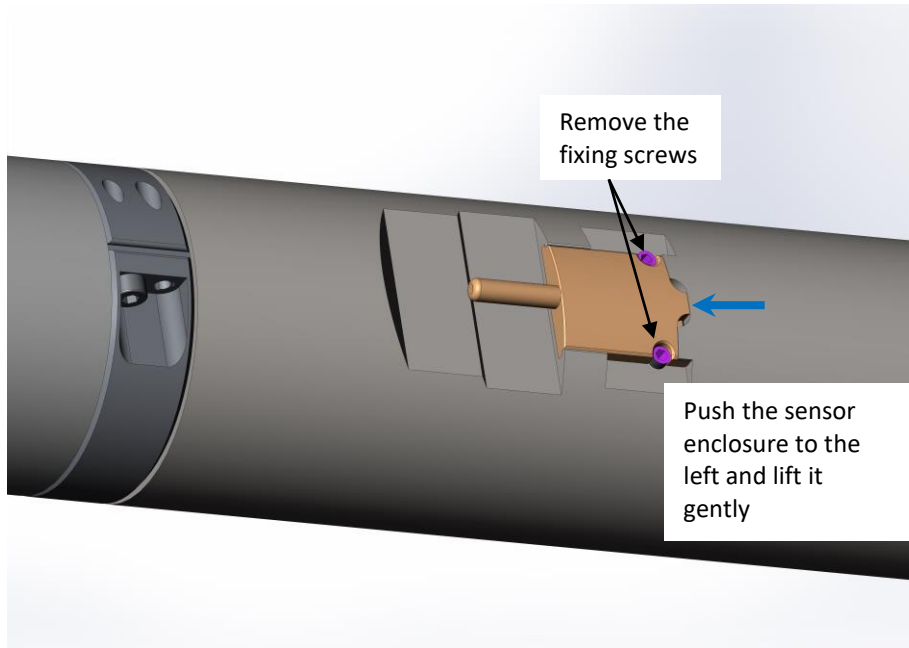

Schematic drawing of the process – Figure 5-32

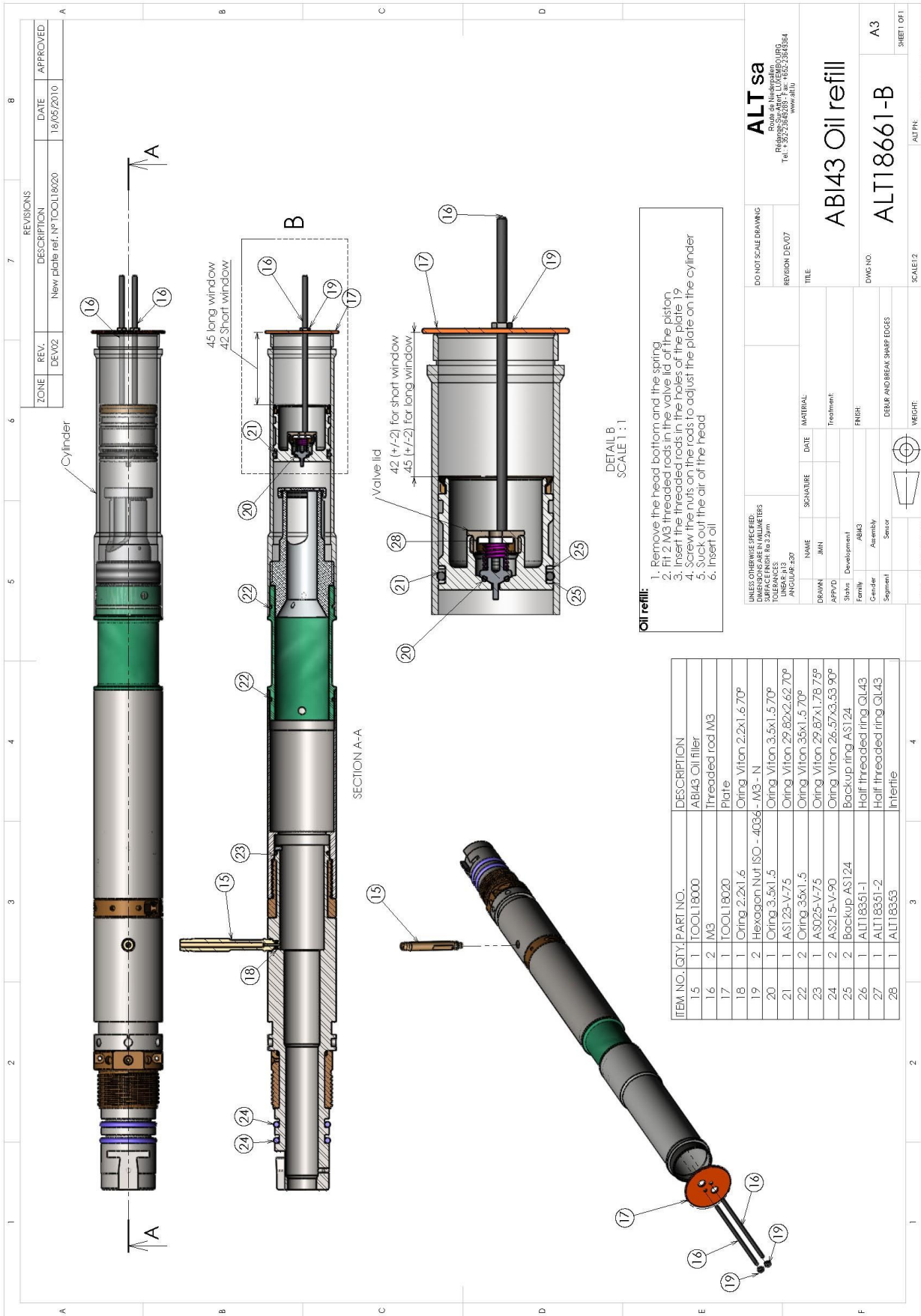

5.3 Handling the electronic cartridge

5.3.1 Extracting the electronic cartridge from the pressure housing

The following instructions describe how to extract the electronic cartridge from the pressure housing.

The O-rings replacement must always be carried out as mentioned in 5.4 to prevent damage of the new O-rings on other parts.

Step 1:

Set the cartridge extractor delivered with your QL43 probe in the inferior connection.

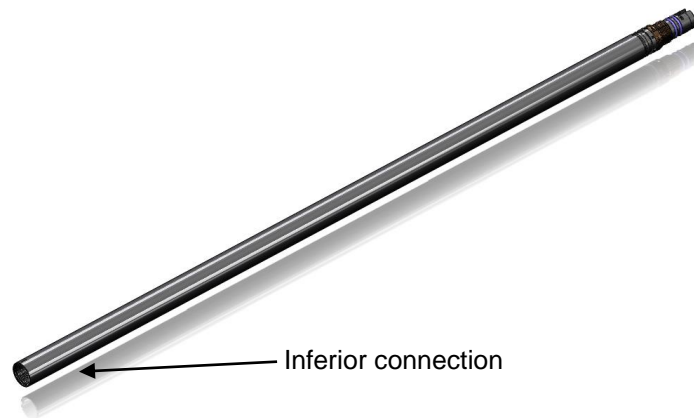

Figure 5-34 QL43ABI cartridge

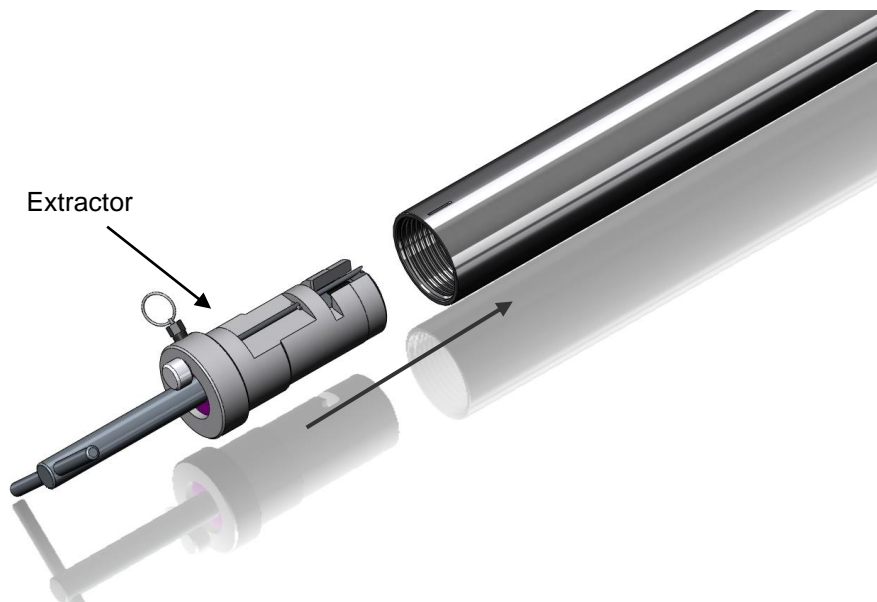

Figure 5-35 Extractor

Step 2:

Push the extractor handle and turn it clockwise until the locking pin is set. Then, push the lowering pin to unlock the inferior connector from the pressure housing.

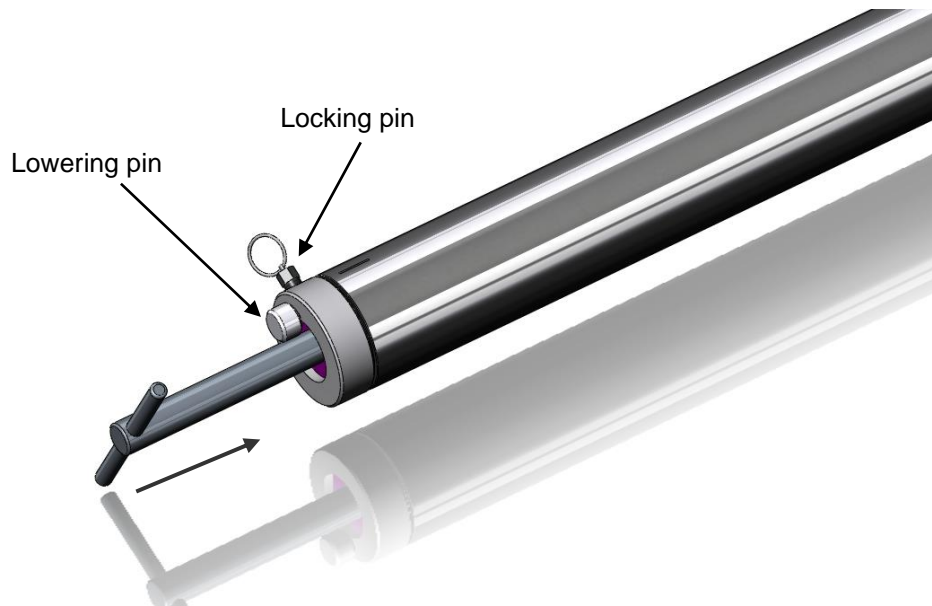

Figure 5-36 Extractor locking

Step 3:

Pull the extractor handle. Now, the electronic cartridge can be completely extracted from the pressure housing.

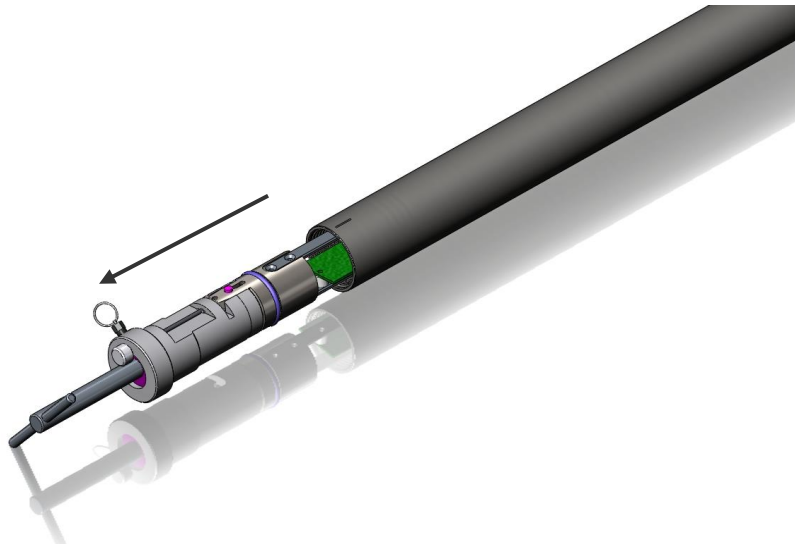

Figure 5-37 Removing of the cartridge

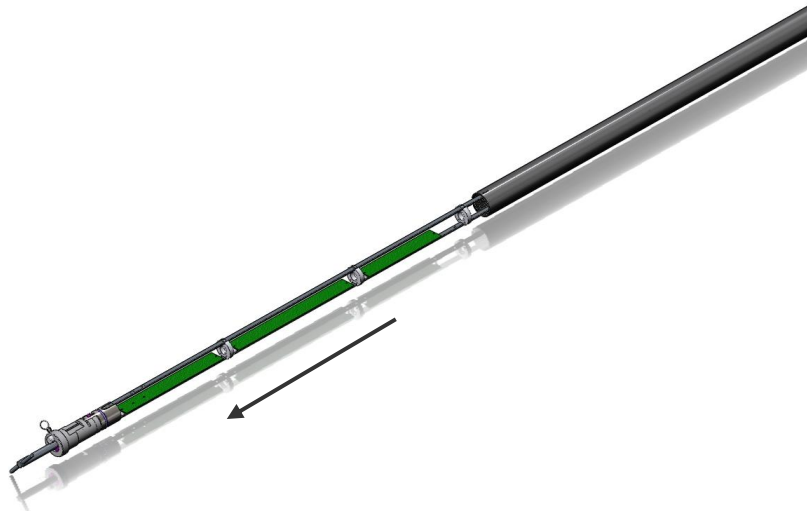

Figure 5-38 Removing of the cartridge

5.3.2 Inserting the electronic cartridge into the pressure housing

The following procedure describes how to install the electronic cartridge in the pressure housing.

Step 1:

Insert the electronic cartridge into the pressure housing and slide it in until it is completely engaged on the extractor.



Figure 5-39 Inserting the electronics into the pressure housing

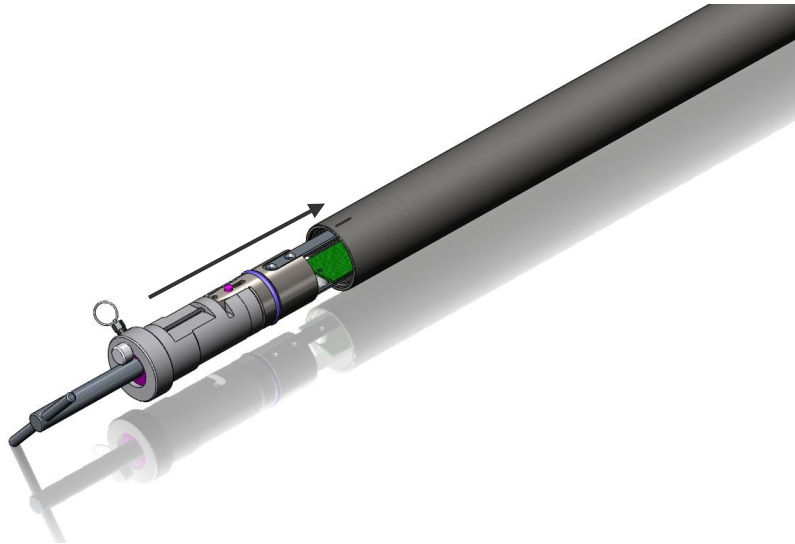

Figure 5-40 Inserting the electronics into the pressure housing

Step 2:

Pull the lowering pin of the extractor to release the finger and lock the inner connector in the pressure housing.

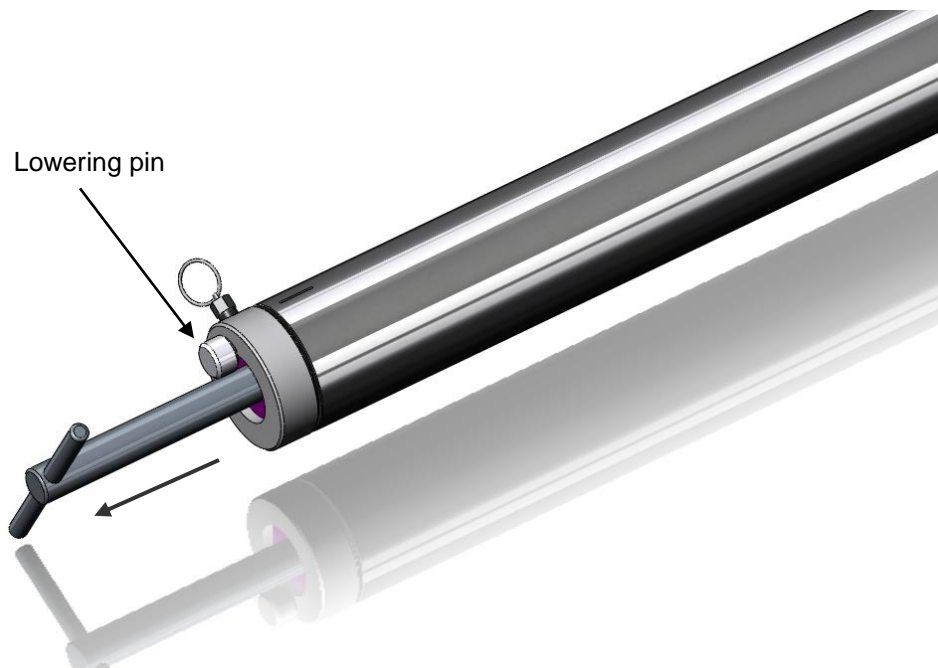

Figure 5-41 Unlocking the inner connector

Step 3:

Once the electronic cartridge is locked in the pressure housing, pull the ring of the locking pin and rotate the handle counter-clockwise to disconnect the extractor from the inferior connector. Remove the extractor.

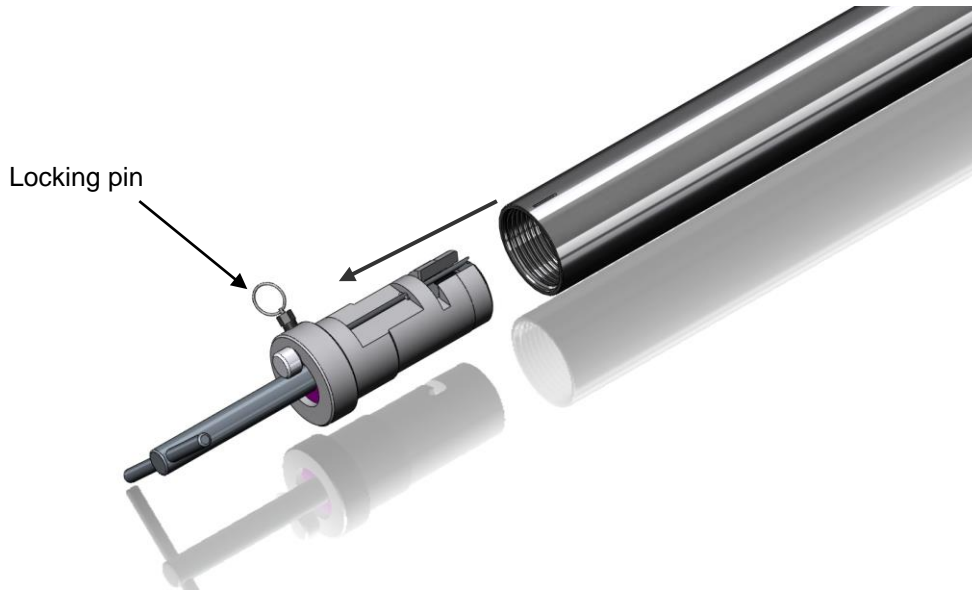

Figure 5-42 Removing of the extractor

5.4 Changing the Quick Link connection O-rings

The following section describes how to replace the Orings of the Quick Link connections.

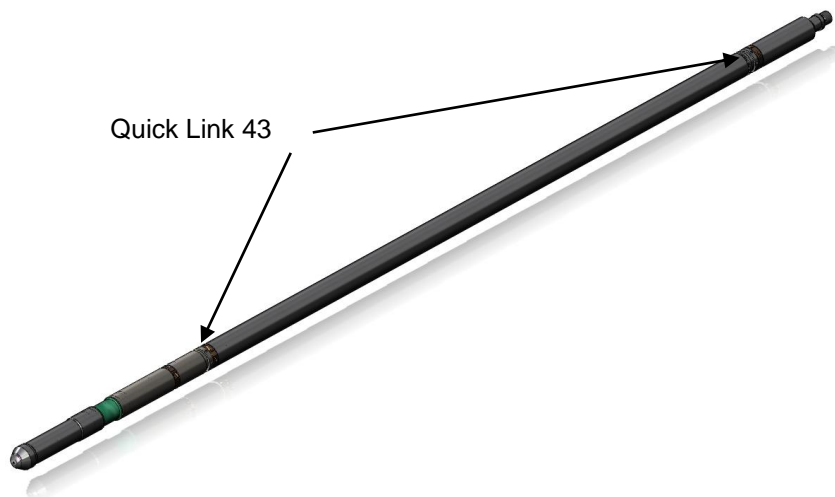

Figure 5-43 Quick Link connections of the QL43AB1

Step 1:

Unscrew the threaded ring with the C-spanner supplied with the probe (Figure 5-23).

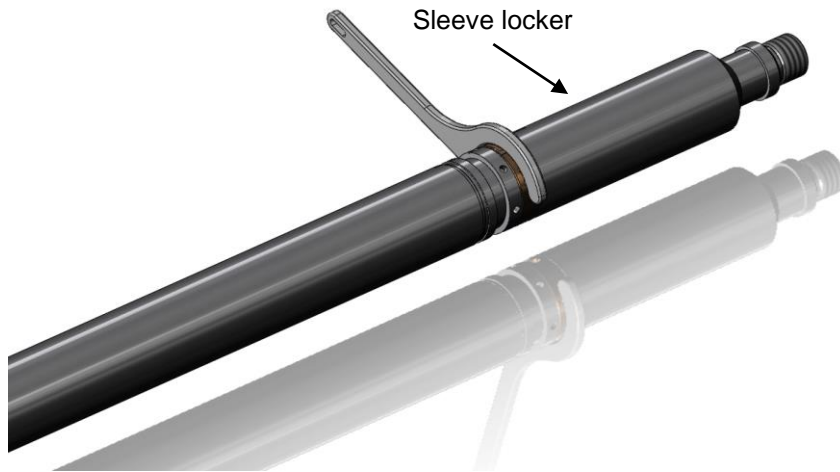

Figure 5-44 Quick Link disconnection

Step 2:

Once the threaded ring is unscrewed, pull on both parts of the link.

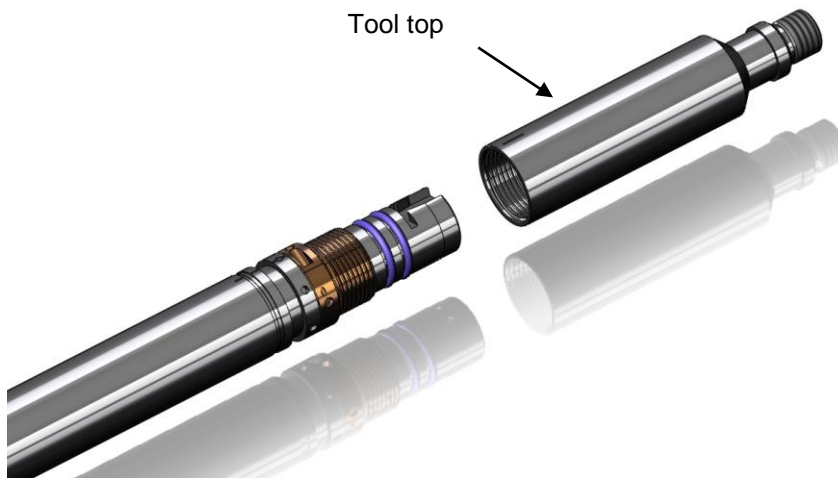

Figure 5-45 Quick Link disconnection

Step 3:
Remove the O-rings.



Figure 5-46 Quick link O-rings

Step 4:
Set the new Orings (AS215, Viton, shore 90) primed with silicon grease.



Figure 5-47 Quick link O-rings

6 Troubleshooting

Observation	To Do
<i>Tool not listed in Tool panel drop down list.</i>	<ul style="list-style-type: none"> - Do you have a configuration file? - Has the configuration file been copied into the .../Tools folder (refer to LoggerSuite manuals about details of the directory structure)?
<i>Tool configuration error message when powering on the tool.</i>	<ul style="list-style-type: none"> - Check all connections. - Adjust the telemetry settings for your wireline configuration (see chapter 3.2 or 3.3) and store the new settings as default. Apply the appropriate tool settings for your logging run (see chapter 3.4).
<i>Tool panel - No current.</i>	<ul style="list-style-type: none"> - Verify that the wireline armour is connected to the logging system. Test your interface cable between winch and data acquisition system. - Verify cable head integrity. - Verify voltage output at the cable head.
<i>Tool panel - Too much current (red area).</i>	<p>! Immediately switch off the tool !</p> <ul style="list-style-type: none"> -Possible shortcut (voltage down, current up): Check for water ingress and cable head integrity - wireline continuity. - Verify the interface cable between winch slip ring and data acquisition system is not loose at the connectors. Check for possible source of a shortcut. - If the above shows no issues, use test cable provided by ALT to verify tool functionality. - If the problem still occurs, please contact service centre.
<i>Telemetry panel - status shows red.</i>	<ul style="list-style-type: none"> - Verify the telemetry settings for your wireline configuration (see chapter 3.2 or 3.3). - If problem cannot be resolved contact support@alt.lu .
<i>Telemetry panel - memory buffer shows 100%.</i>	<ul style="list-style-type: none"> - Indicates that the systems internal memory buffer is full. PC can't receive incoming data streams fast enough. Ensure your PC has enough resources available.
<i>Telemetry panel – bandwidth usage shows 100%. (Overrun error message.)</i>	<ul style="list-style-type: none"> - Set the baudrate to highest value allowed by your wireline configuration. - Reduce logging speed, decrease azimuthal resolution and/or increase vertical sample step.
<i>Telemetry panel - large number of errors.</i>	<ul style="list-style-type: none"> - Verify the telemetry settings for your wireline configuration (see chapter 3.2 or 3.3). - Check bandwidth usage and telemetry error status.

Observation	To Do
<p><i>Permanent No Sync message and red led status in MChNum browser.</i></p> <p><i>Motor stalled and increase of current drawn by the tool.</i></p>	<p>! Immediately switch off the tool !</p> <p>- Stepper motor and mirror synchronization issue. Contact ALT for Acoustic Head service.</p>

7 Notes on Data Processing

The processing of data acquired with the QL43 ABI tool is usually performed using the WellCAD software. We would like to refer the user to the WellCAD user guides for a detailed description of the software's functionality. In particular *Book 3 - Image & Structure Module* should be of help when processing image data.

The following paragraphs will focus on three processes to process traveltime data for which the input of correct units and parameters is crucial in order to obtain accurate results.

7.1 Estimation of Fluid Velocity

The procedure described below outlines the estimation of the borehole fluid velocity which can be used as input for the computation of caliper data described hereafter.

1. From the **Process > Image Module > Image Logs** menu in WellCAD select the **Estimate Fluid Velocity** entry. The corresponding options dialog box will open (Figure 7-1).

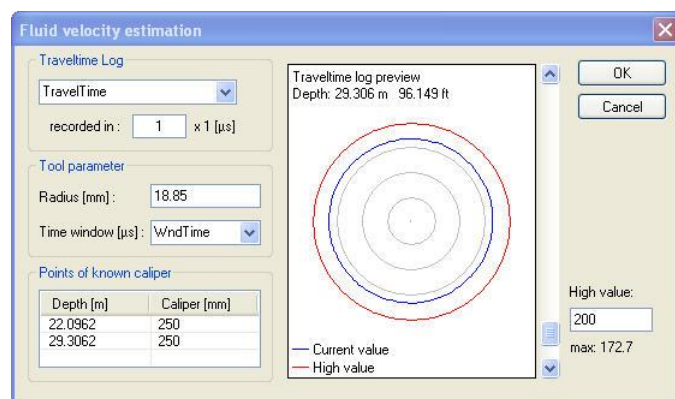
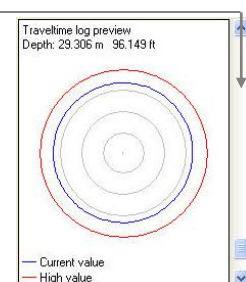
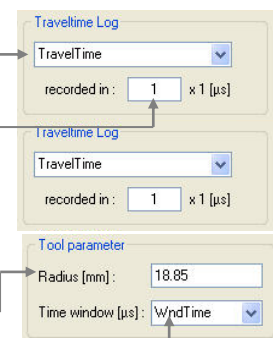

Figure 7-1 Fluid velocity estimation dialog box

2. Select the TravelTime log from the corresponding drop down list in the dialog box.
3. Set the unit the traveltime has been recorded in. For the QL43 ABI tool this manual refers to the unit is 1 μs .
4. Enter the radius of the acoustic head at the measurement point into the corresponding edit box. For the ABI 43 tool described here a value of 18.85 mm is appropriate.
5. Select the Time window channel *WndTime* which contains the traveltimes from transducer to the acoustic head window and back (has been recorded by your tool along with the other measurements).
6. Use the scroll bar next to the preview of the cross sections generated from the traveltime data and find a depth at which the caliper of the pipe or borehole is known and best reflected by the measurement (for example the nominal internal diameter of casing or the bit size).



- Right click into **Points of known caliper** list and add a new row for a reference point. The depth value will automatically set to the depth of the preview. Enter the known caliper value in [mm].

Depth [m]	Caliper [mm]
22.0962	250
29.3062	250

- Try to set a least a reference point at or near the top and base of the well. Click **OK** when finished. A new log containing the estimated velocity profile will be created.

7.2 Computation of Caliper Data

The following steps summarize the steps to compute radius and caliper data from the acoustic traveltime recorded with your ABI tool:

- Select the **Calculate Caliper** process from the **Process > Image Module > Image Logs** menu. The options dialog box (Figure 7-2) will open.

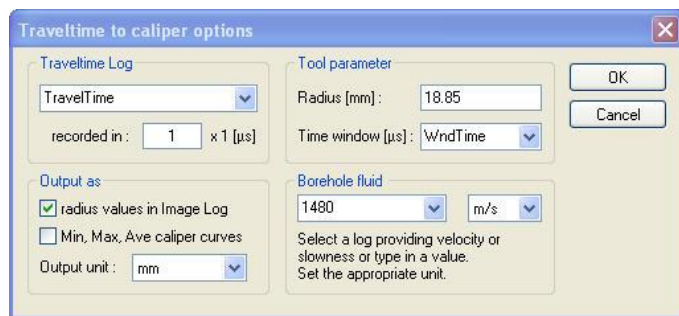

Figure 7-2 Traveltime to caliper conversion dialog box

- Select the TravelTime log from the corresponding drop down list in the dialog box.
- Set the unit the traveltime has been recorded in. For the QL43 ABI tool this manual refers to the unit must be set to 1 μs .
- Enter the radius of the acoustic head at the measurement point into the corresponding edit box. For the ABI 43 tool described here a value of 18.85 mm is appropriate.
- Select the Time window channel *WndTime* which contains the traveltimes from transducer to the acoustic head window and back (has been recorded by your tool along with the other measurements).
- If you estimated a fluid velocity as described in the paragraph above or have measured values extend the drop down list and select the corresponding log. You can also enter a textbook value manually. Ensure the correct unit has been selected.
- Select the output options and unit. You can create a new Image Log containing a radius value for each traveltime measurement. In addition you can create Min, Max and Average caliper curves.
- Click on **OK** to close the dialog box and start the computation.

7.3 Calculation of Casing Thickness

If you made measurements in cased hole mode you will get a log containing the traveltime within the steel casing (thickness travel time). The procedure described below summarizes the conversion of the thickness traveltime into a true thickness value.

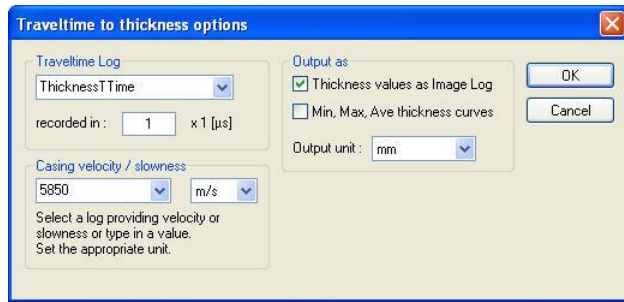
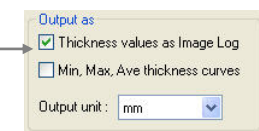
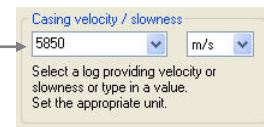
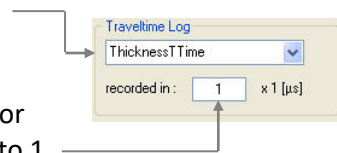

Figure 7-3 Travelttime to casing thickness conversion dialog box

- From the **Process > Image Module > Image Logs** menu in WellCAD select the Calculate Thickness... entry. The corresponding options dialog box will open (Figure 7-3).
- Select the ThicknessTTime log from the corresponding drop down list in the dialog box.
- Set the unit the thickness traveltime has been recorded in. For the QL43 ABI tool this manual refers to the unit must be set to 1 μs .
- Enter the velocity of sound in steel into the corresponding edit box. A typical value for steel is 5850 m/s. If you have a velocity profile available in a log extend the drop down list and select the corresponding channel.
- Choose the output option and unit. The thickness values can be given as a Image Log with on thickness value for each traveltime thickness measurement and as curve of the minimum, maximum and average thickness determined.
- Click on **OK** to close the dialog box ad start the computation.



8 Appendix

8.1 Tool Communication with OPAL/SCOUT

The telemetry provided through the OPAL-SCOUT systems implementing the ALT MODEM adapter is self-tuning. In case communication status is not valid the user has different options to adjust manually the telemetry settings from the telemetry panel of the dashboard:

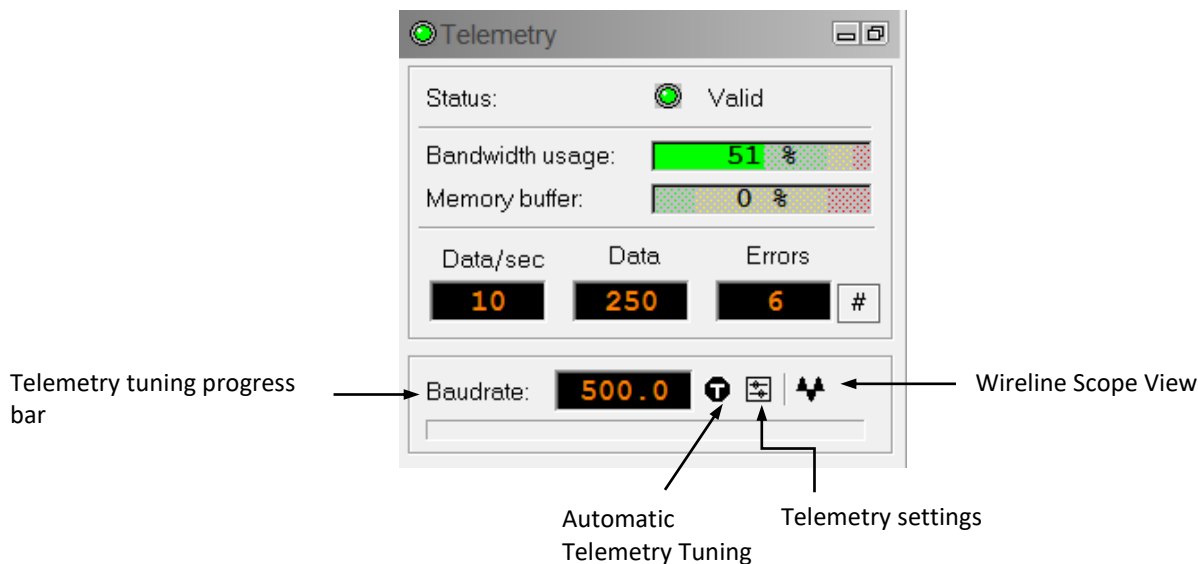

Baud rate:

Indicates the default baud rate or optimal baud rate in kbps found by the system for the selected winch/telemetry scheme

Automatic Telemetry Tuning:

The Tune button  resets the telemetry tuning automatically. This process defines:

- the optimum baud rate for the winch configuration selected
- a transfer function and a filter to re-construct at the surface the shape of the pulse trains distorted by the wireline.⁴ Refer to the **Equalizer** paragraph for more details.

The Automatic Tuning is very useful on wireline over 1000m length to optimize the telemetry performance and logging speed.

A **progress bar** at the bottom of the telemetry window shows the progression of the telemetry tuning. At the end of the process the baud rate display is refreshed with the optimal baud rate value.

⁴ The transfer function and filter concept are only valid for tools implementing the latest generation of ALT MODEM telemetry board (i.e. QL40-ABI2G, ABI-GR-2G, QL40-OBI2G, OBI-GR-2G, QL43-ABI2G,...)

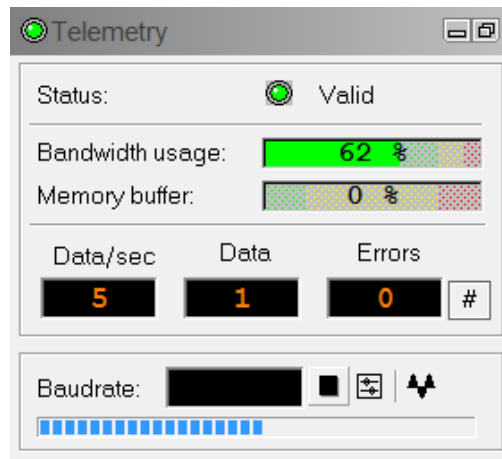

Scope:

Pressing the scope button  on the **Telemetry Panel** brings up a **Wireline Scope** view (Figure x), which displays the pulse strings transmitted through the wireline and received by the system at the surface.

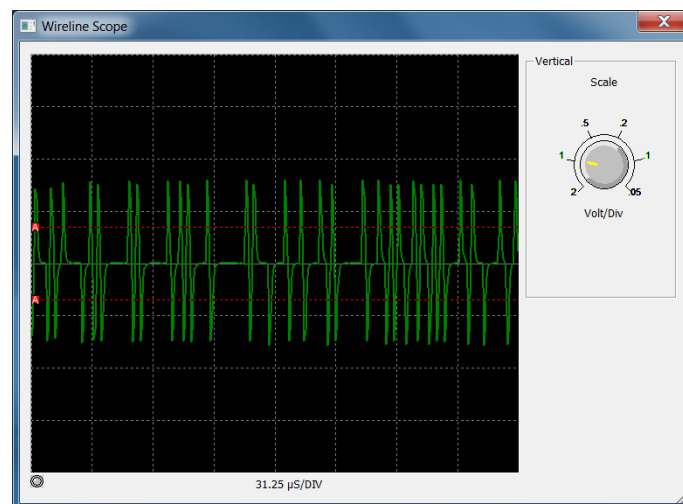

The two red-dashed horizontal lines help to visualize the position of the discriminator levels set for detecting the pulses at the surface. Discriminator levels can be tuned in the **Telemetry Settings** dialog – refer to section 3.6.1 for more information.

The Scale knob can be adjusted to show more or less vertical details. This view has no effect on the communications and is a visual aid only.

Telemetry Settings:

The Telemetry Settings button  opens a **Telemetry** control panel summarizing the telemetry status and configuration.

If the system cannot establish a stable communication with the tool, the **Settings and Equalizer tabs** allow the user to modify the telemetry settings and to apply a telemetry filter (Equalizer option)

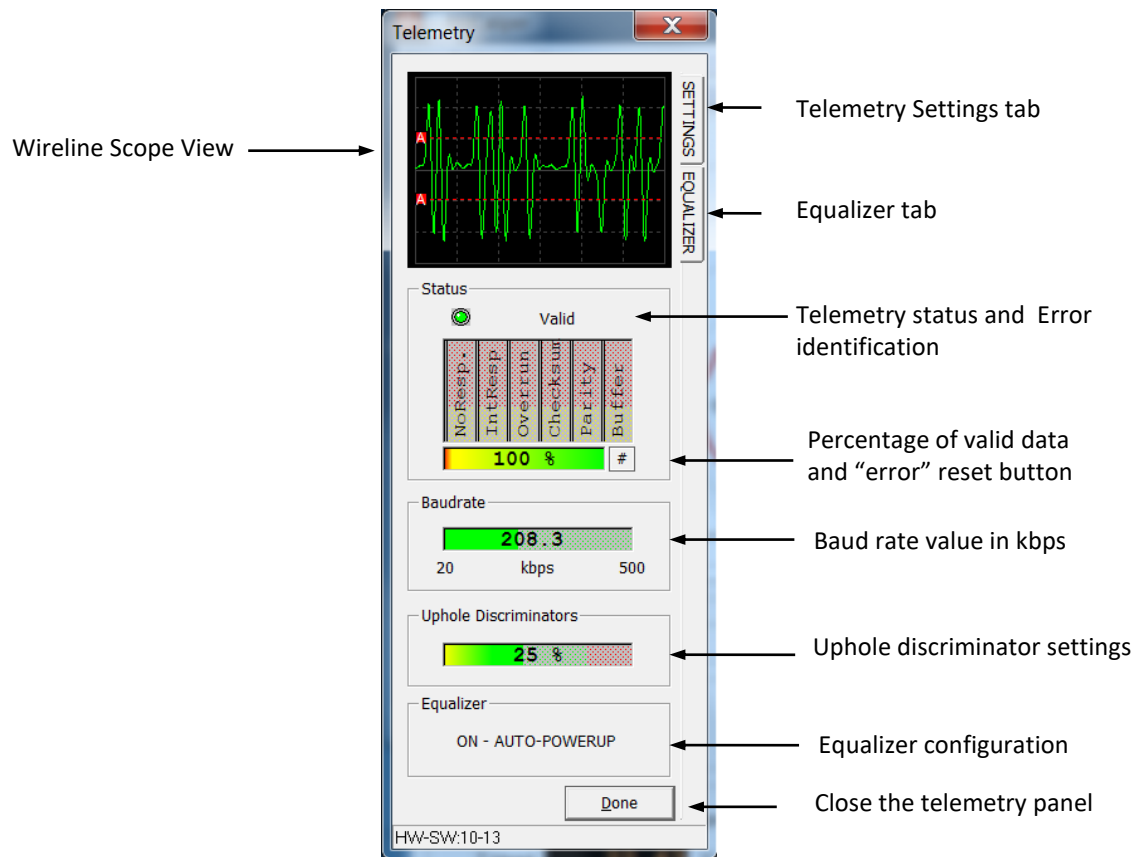

Adjusting the Telemetry Settings:

By default the telemetry settings are set to Automatic mode and should stay in this configuration. When more advanced tuning is required (i.e. long wirelines having a limited bandwidth) the manual mode can be activated.

In Automatic mode the uphole discriminators are set automatically to detect the pulse strings.

The position of the discriminator levels are visible on the Scope and Analysis views and are represented by two red dashed lines – one for the positive pulses and the other for the negative pulses.

The “A” letter on the red square means that the discriminators are set in automatic mode. The **Scale knob** controls the scale for the Analysis and Scope displays.

Position of the discriminator lines should be set as illustrated below.

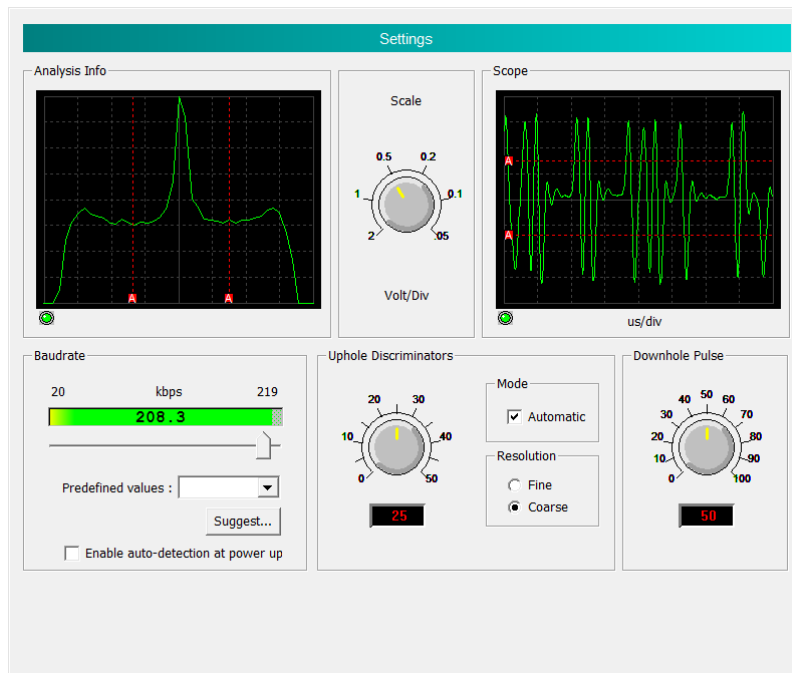

When the automatic mode is unchecked user has the option to adjust manually the uphole discriminators using either the discriminator knob or by moving interactively the red dashed lines in the Analysis and Scope displays. The red triangles located at the extremities of the red dashed lines refer to manual mode. For fine tuning of the discriminators the **Fine resolution** can be chosen.

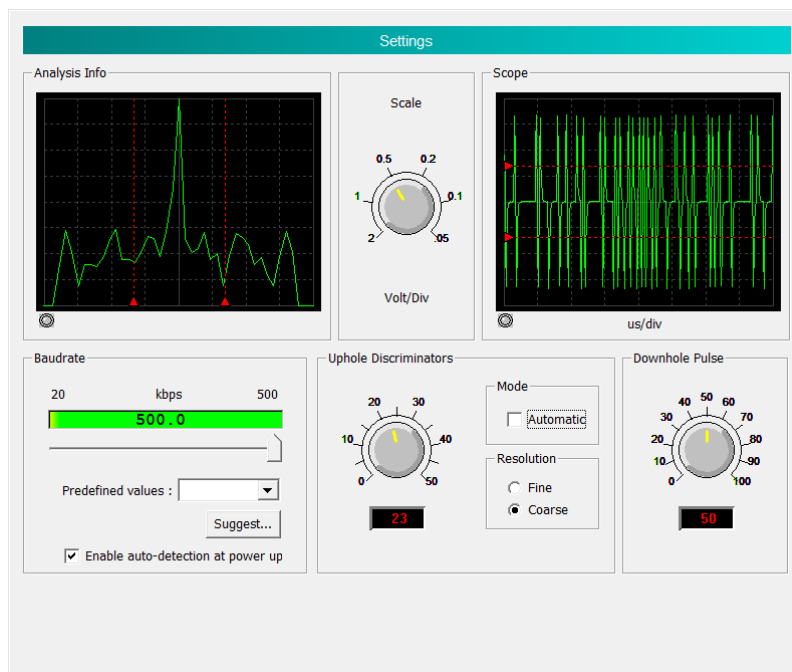

The **Downhole Pulse knob** controls the width of the pulse commands sent to the tool. It is set on 50 as a default value. This value is the preferred one and is suitable for a wide range of wirelines. For long wireline increasing the pulse width could help to stabilize the communication. The reverse for short wireline.

The **Baudrate** is generally set to the maximum value for which the communication status stays valid in order to optimize the logging speed for the wireline configuration. The baudrate can be adjusted by moving the cursor below the baudrate bar meter or by selecting a predefined baudrate value from the select box.

When clicking the **Suggest** button the system is searching for the optimum baudrate value and keeps this value for the data transmission.

The **Enable auto-detection at power-up** configures the system such a way that the baudrate is reset to its optimum value each time a tool is powered up.

Applying the Equalizer

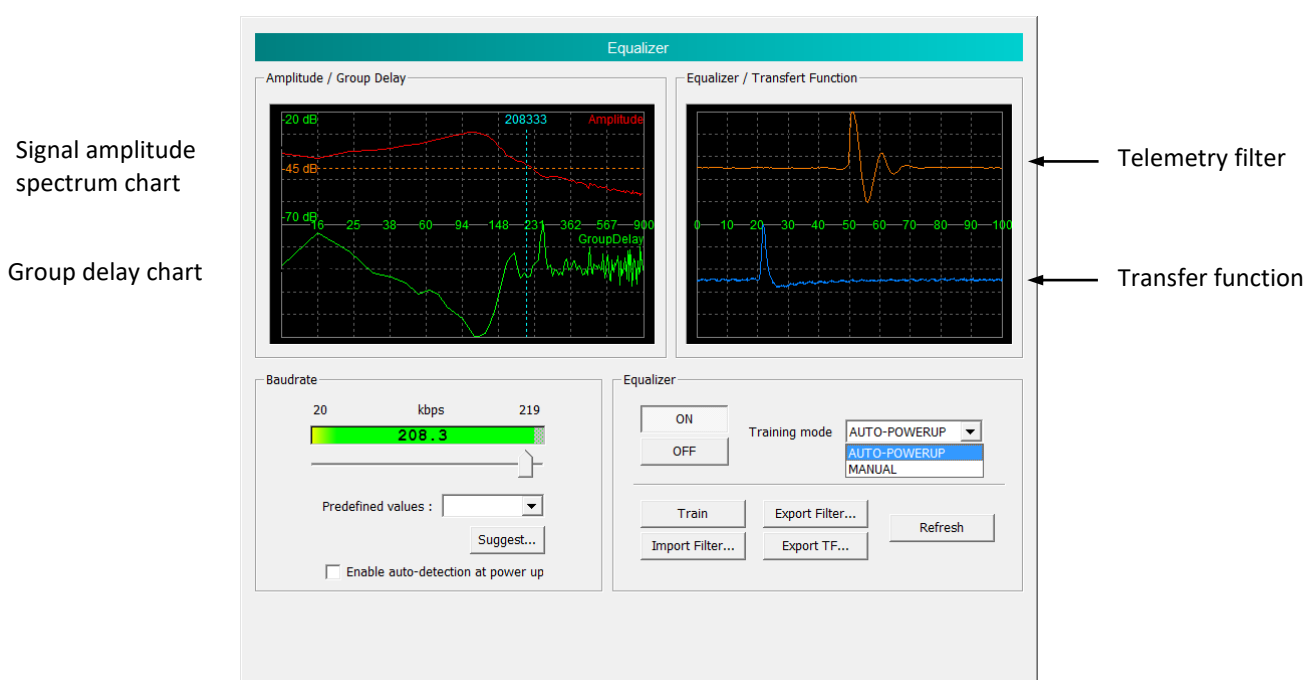

The **Equalizer** dialog provides some advanced telemetry settings described hereafter.

- The **Train** button computes the transfer function of a wireline - refer to the blue signal. When clicking on Train the tool sends a pilot pulse frame to the surface. The received signal at the surface is compared with the original pilot pulse frame to measure the distortion of the signal through the wireline. The result of this process is the definition of a transfer function specific to the wireline used.

A filter is then derived from the transfer function - refer to the orange signal. The filter will be applied on the telemetry signal to counteract the distortion of the pulse strings through the wireline.

Applying the filter will thus improve the telemetry performance of the system and logging speed on wirelines with unfavorable band width.

- The **Equalizer ON/OFF** buttons enables or disables the filter. The activation of the equalizer can be configured to **MANUAL** mode or to **AUTO-POWERUP**.

The AUTO-POWERUP feature applies the telemetry filter upon tool power-up.

- The **Export TF** option exports the **Transfer Function** defined by the wireline training process in a ASCII file format
- The **Export Filter** option exports the **Filter** derived from the transfer function in a ASCII format
- The **Import Filter** option loads a saved filter configuration
- The **refresh** button is refreshing the Equalizer/transfer function display

The **Amplitude/Group Delay** charts are mostly used by ALT developers for telemetry signal and performance analysis.

The Equalizer dialog repeats the **Baudrate** settings already discussed in the previous paragraph "Adjusting telemetry settings".

8.2 Parts list

8.2.1 QL43 O-ring Spares kit (ref. 209-007)

Reference	Description	Qty
AS215-V-90	O-ring Viton 514320 26.57x3.53-90°	10

8.2.2 QL43 ABIHEAD – maintenance kit (ref. 209-006)

Reference	Description	Qty
OR2x1.6-V-75	O-ring Viton 51414 R00 2.2x1.6-75°	5
OR3.5x1.5-V-75	O-ring Viton 51414 3.5x1.5-75°	5
OR35x1.5-V-75	O-ring Viton 51414 35x1.5-75°	5
AS123-V-75	O-ring Viton 51414 29.82x2.62-75°	5
AS215-V-90	O-ring Viton 514320 26.57x3.53-90°	10
BACKUP AS124 SP	Backup ring PTFE SP AS124	5
IFLMP2M02B0P0050G	IKV-FLUOR MPA 2H (50g)	1

Index

A, 30
AbiCaliper, 34
AbiSurfacelmg, 31
AbiThicknesslmg, 33
Acoustic head, 40
Acoustic head operation, 10
ALT Logger, 15
Azimuth, 30
Azimuth accuracy, 8
Azimuthal Resolution, 17, 26
Baudrate, 15
Calculation of Casing Thickness, 71
Caliper Browser Window, 34
cartridge extractor, 59
Cleaning the acoustic head bottom section, 43
Computation of Caliper Data, 70
Configuring Tool Parameters, 17
Diameter, 7
Dimensions, 6
discriminators, 15
Downhole Pulse width, 15
electronic cartridge, 59
Estimation of Fluid Velocity, 69
Extracting the electronic cartridge, 59
Functionality test, 37
General Information, 5
Gravity, 30
head, 10
impedance, 10
Inclination accuracy, 8
Inserting the electronic cartridge, 61
Length, 7
Level 1 maintenance, 43
Level 2 maintenance, 46
Magn.Field, 30
Maintenance, 39
MATRIX, 15
Max. Temp, 7
Max.Pressure, 7
MChNum Browser Window, 31
Measurement Principle, 9
Mirror rotation, 37
Motor Period, 30
Motor Status, 30
MotSpeed, 30
Mroll, 30
Notes on Data Processing, 69
Oil, 53

Oil filler, 54
Operating Procedure, 13
O-rings, 63
Overview, 5
Parts list, 78
Performance Check & Calibration, 37
Piston cleaning, 48
Quick Start, 13
R, 30
RBR, 30
Refilling oil, 53
Reflection coefficient, 10
Removing oil from the head, 47
Removing the ABI43 acoustic head, 41
Roll, 30
Rolling test, 37
RThead, 30
RTmotor, 30
S, 30
Schematic drawing, 57, 58
Surface Image Browser Window, 31
T, 30
T APS, 30
T CPU, 30
T Head, 30
T Motor, 30
Technical drawings, 78
Technical Specification, 7
Telemetry, 15
Thickness Image Browser Window, 33
Tilt, 30
Tool Communication with ALT Logger, 15
Tool Communication with MATRIX, 15
Tool Head Adapter, 39
Trouble Shooting, 66
VT CPU, 30
Weight, 7
WndAmpl, 30
WndTime, 30