

User Guide

QL40 ABI (2G) Acoustical Borehole Imager



Advanced Logic Technology sa

Bat A, Route de Niederpallen
L-8506 Redange-sur-Attert
Luxembourg

Phone : +352 23 649 289
Fax : +352 23 649 364
Email : support@alt.lu
Web : www.alt.lu

Mount Sopris Instruments Co., Inc.

4975 E. 41st Ave.
Denver, CO 80216
USA

Phone : +1 303 279 3211
Fax : +1 303 279 2730
Email : tech.support@mountsopris.com
Web : www.mountsopris.com

Table of Contents

1	General Information	1
1.1	Overview	1
1.2	Dimensions	2
1.3	Technical Specification	3
2	Measurement Principle	5
2.1	Reflection coefficient	5
2.2	Acoustic head operation	6
3	Notes on QL tool assembly	9
3.1	QL40 stack assembly	9
4	Operating Procedure	13
4.1	Preliminary note	13
4.2	Quick Start	14
4.3	Tool Communication with OPAL/SCOUT (ALT MODEM)	15
4.4	Tool Communication with ALT Logger	15
4.5	Tool Communication with MATRIX	16
4.6	Configuring Tool Parameters	17
4.6.1	Operating Modes	17
4.6.2	Azimuthal resolution	27
4.6.3	Additional notes on the waveform preview	27
4.6.4	Advanced Settings	28
4.6.5	Tool details	29
4.7	Recorded Parameters and Browsers	30
4.7.1	Recorded parameters	30
4.7.2	MChNum Browser Window	31
4.7.3	Surface Image Browser Window (AbiSurfaceImg)	32
4.7.4	Thickness Image Browser Window (AbiThicknessImg)	33
4.7.5	Caliper Browser Window (AbiCaliper)	34
5	Performance Check & Calibration	36
5.1	Mirror rotation	36
5.2	Functionality test of the deviation system	36
5.2.1	Functionality test	36
5.2.2	Rolling test – azimuth and tilt check	36

6	Maintenance	37
6.1	Tool Top Adapter	38
6.2	Acoustic head	40
6.2.1	Cleaning the acoustic head bottom section	41
6.3	Pressure Housing	42
6.4	Upgrading ABI firmware	42
6.4.1	Checking the communication	42
6.4.2	Upgrading the firmware	43
7	Troubleshooting.....	47
8	Notes on Data Processing.....	49
8.1	Estimation of Fluid Velocity.....	49
8.2	Computation of Caliper Data.....	50
8.3	Calculation of Casing Thickness.....	51
9	Appendix	53
9.1	Tool Communication with OPAL/SCOUT	53
9.2	Parts list	58
9.3	Technical drawings	58
	Index.....	59

1 General Information

The QL40 ABI is the latest generation of acoustic televiewer. Based on 20 years of experience and market leadership with BHTV technology, the new system consists of a completely redesigned acoustic sensor and new electronics. The electronic architecture uses a 96 dB-10Mps A/D converter directly coupled to a 150 Mflops DSP digital signal processor. The DSP is performing complex data processing operations in real time on each individual ultrasonic wave train and that allows a wider dynamic range of signal detection and easy field operation in a wide variety of logging applications.

The QL40 ABI tool is supplied as a bottom sub of the Quick Link (QL) product line and can be combined with other QL40 tools to form a tool string or it can be run as a stand alone tool. The ABI40 is the standalone - non stackable - version.

1.1 Overview

Acoustic borehole scanner tools generate an image of the borehole wall by transmitting ultrasound pulses from a fixed transducer with rotating mirror and recording the amplitude - travel time of the signals reflected at the interface between borehole fluid and the formation (borehole wall). The QL40 ABI has multi-echo capability. This is achieved by digitally recording the reflected acoustic wave train. On line analysis of the acoustic data is made by the DSP. Sophisticated algorithms allow the system to detect the reflection from the acoustic window and to separate and classify all subsequent echoes. Minimum input from the operator is needed to enable:

- Automatic or manual adaptation to variable borehole conditions.
- Improved dynamic range of signal detection.
- Very high travel time resolution.
- The implementation of different operating modes. For example, when run inside PVC casing, the tool can record both the echo of the PVC casing and that of the borehole wall. With multi-echoes processing, application of the tool may be extended to steel casing thickness and corrosion evaluation.

Remark:

Tools manufactured from year 2020 benefit of the latest firmware developments making the Thickness measurement more robust in adverse borehole conditions where the signal over noise ratio is defavorable.

1.2 Dimensions

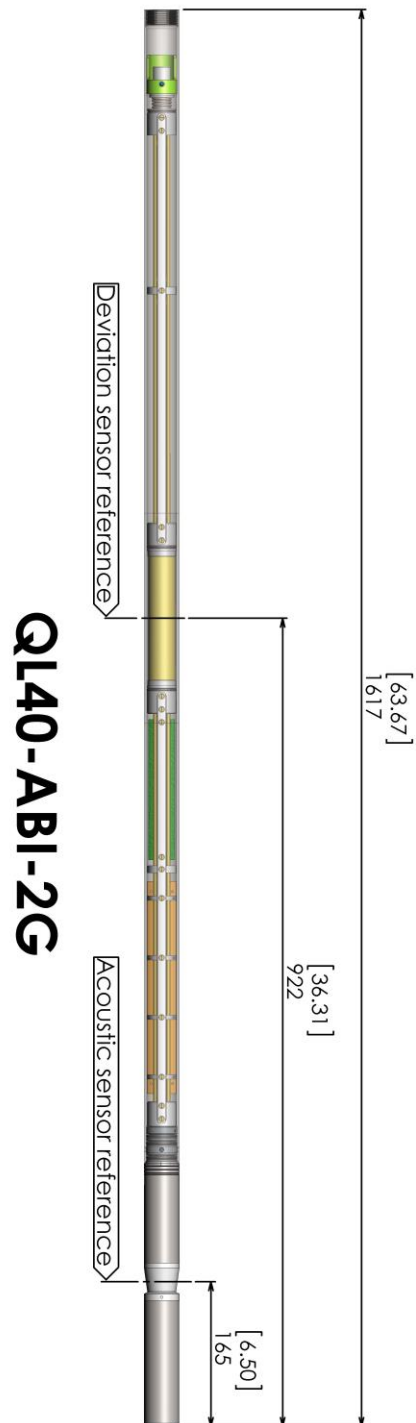

Figure 1-1 QL40-ABI-2G dimensions

1.3 Technical Specification

Tool

Diameter:	40mm
Length:	1.62m (63")
Measurement point:	0.165m (from probe bottom)
Weight:	6.7 kg (14 .7 lbs)
Max. Temp:	70°C
Max.Pressure:	200bar

Cable:

Cable type:	Mono, Coaxial, 4 or 7 conductor
Digital data transmission:	Up to 500 Kbits per second depending on wireline
Compatibility:	ALTlogger – BBOX – Matrix

Acoustic sensor:



Figure 1-2 Acoustic head

Acoustic sensor:	Fixed transducer and rotating focusing mirror
Measurement range ¹ :	2.5" – 20" (64mm-500mm)
Focusing diameter ² :	6" (152mm)
Frequency:	1.2 Mhz
Acoustic beam width:	1.5 mm (at focal point)
Rotation speed:	Up to 35 revolutions per second - automatic
Azimuthal resolution:	Open Hole Mode - 72, 144, 216, 288, 360 operator defined
	Cased Hole Mode - 72, 144 operator defined
Caliper resolution:	0.08mm

¹ Diameter range of the hole in which the measurement is possible (depends on borehole conditions).

² Diameter of the hole where the focusing of the acoustical beam is optimum.

Orientation sensor:

LoggerSuite:	11.1.1227 or higher
WellCAD	4.4.3303/13303 or higher
Sensor:	APS544
Location:	Middle point of sensor located at 0.92m from tool bottom
Orientation:	3 axis fluxgate magnetometer, 3 accelerometers
Inclination accuracy:	0.5 degree
Azimuth accuracy:	1.2 degree

Software requirements:

LoggerSuite	11.1.1227 or higher
WellCAD	4.4.3303/13303 or higher

Logger firmware requirements:

Matrix	113 – 117 - 100
Jazz - BBOX	108

2 Measurement Principle

An understanding of the basic principles of operation of the televiewer is essential for successful use of the tool. The ABI produces images of the borehole wall which are based on the amplitude and time of travel of an ultrasonic beam reflected from the formation wall. The ultrasonic energy wave is generated by a specially designed piezoelectric ceramic crystal and has a frequency of around 1.2MHz. On triggering, an acoustic energy wave is emitted by the transducer and travels through the acoustic head and borehole fluid until it reaches the interface between the borehole fluid and the borehole wall. Here a part of the beam energy is reflected back to the sensor, the remainder continuing on into the formation medium at a changed velocity (Figure 2-1). By careful time sequencing the piezoelectric transducer acts as both transmitter of the ultrasonic pulse and receiver of the reflected wave. The travel time for the energy wave is the period between transmission of the source energy pulse and the return of the reflected wave measured at the point of maximum wave amplitude. The magnitude of the wave energy is measured in dB, a unit less ratio of the detected echo wave amplitude divided by the amplitude of the transmitted wave.

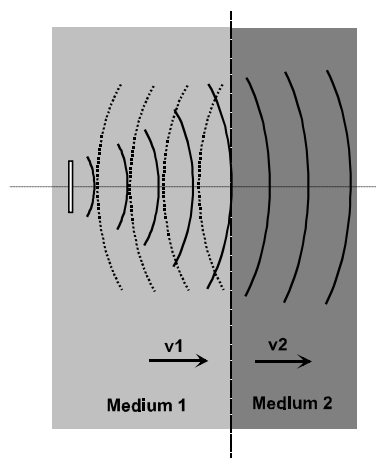

Figure 2-1 Wave propagation

2.1 Reflection coefficient

The strength of the reflected signal depends principally on the impedance contrast between the borehole fluid and the formation (Figure 2-1).

The reflection coefficient r is given by the following equation:

$$r = (\rho_b v_b - \rho_m v_m) / (\rho_b v_b + \rho_m v_m)$$

where ρ_b = density of formation
 ρ_m = density of borehole fluid
 v_b = velocity of sound of formation
 v_m = velocity of sound of borehole fluid

The larger the reflection coefficient is the greater is the signal reflection and thus the ability to detect the signal. From the equation above it may be seen that when the properties of the borehole fluid and borehole wall are similar, i.e. $\rho_b v_b \approx \rho_m v_m$, the reflection coefficient r approaches zero and there is negligible reflection. In this situation determination of the true reflected wave is made more difficult.

2.2 Acoustic head operation

The acoustic wave is generated by applying a high voltage pulse across the two faces of a piezo ceramic disc. The applied voltage causes deformation within the crystal structure, either an expansion or contraction depending on the polarity of the applied voltage, with a resultant energy wave emitted normal to the free surface. It has been shown that the beam generated by this process has a maximum energy at a distance of twice the diameter of the disc and that after this point the beam tends to diverge. In order to optimize the beam energy at the point of investigation the ALT televiewer head has been designed as illustrated below (Figure 2-2).

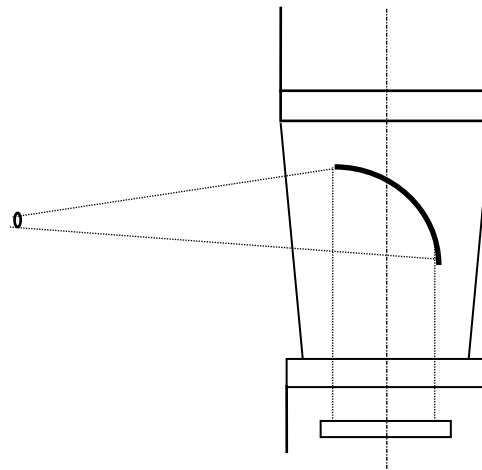

Figure 2-2 Focussing arrangement

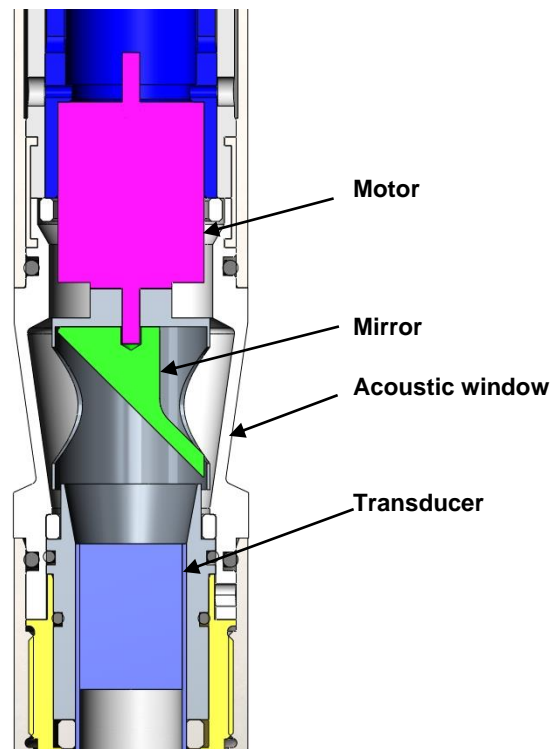

Figure 2-3 QL40 ABI acoustic head architecture

The acoustic wave propagates along the axis of the tool body and is then reflected perpendicular to this axis by a special reflector that focuses the beam to a high-energy point of ± 1.5 mm diameter. The radial distance of the focal point from the axis of the tool is determined by the focal length of the mirror, ± 75 mm (for an acoustic head with a 6" focusing mirror).

The frequency of the transmitted wave is determined amongst other factors such as ceramic composition by the diameter of the piezo transducer, a smaller diameter giving a higher frequency. The ALT televiewer operates around 1.2MHz.

The reflector is mounted on the drive shaft of a stepper motor. This enables the position of measurement to be rotated through 360°. Sampling rates of 72, 144, 216, 288 and 360 measured points per revolution are available, thus at maximum resolution a near continuous image of the borehole wall is made. The higher sampling rate can be used for better resolution in larger diameter boreholes but is less useful in small diameters due to overlap of the sampling points.

3 Notes on QL tool assembly

The following explanations are only valid for the QL40 ABI tool versions. ABI40 “standalone” users can skip this chapter.

QL stands for **Quick Link** and describes an innovative connection between logging tools (subs) allowing to build custom tool stacks. QL40 describes a specific family of logging tools. Each sub is equipped with its own Telemetry board, Power supply element and A/D converter allowing an operation as stand-alone tool or as a stack in combination with other subs of the QL product family.

The QL40 probe line deals with two types of subs - Bottom Subs and Mid Subs.

Bottom Sub

A bottom sub is a tool that must have one or more sensors located at the bottom. It can be operated in combination with other QL subs connected to the top but it is not possible to connect another sub below. When used in stand-alone mode the bottom sub only needs a QL40 tool top adaptor, which fits the cable head.

Mid Sub

A mid sub is a tool that can be integrated anywhere within a stack of tools. When used at the bottom of a tool string a QL40 bottom plug must be used to terminate the string. If the mid sub is used as a stand-alone tool it needs a QL40 bottom plug at the lower end and a QL40 tool top adaptor at the top.

3.1 QL40 stack assembly

QL40 tool stacks are terminated by either a QL40 bottom sub or a QL40 bottom plug. At the top of the stack a QL40 tool top is required to connect the tool string to the cable head. Several tool tops are already available, special ones can be made on request.

To assemble and disassemble the subs the C-spanner delivered with the tool must be used (Figure 3-1). It is recommended that before each assembly the integrity of the O-rings (AS216 Viton shore 75) is verified. Prime the O-rings with the silicon grease that was supplied with the subs.

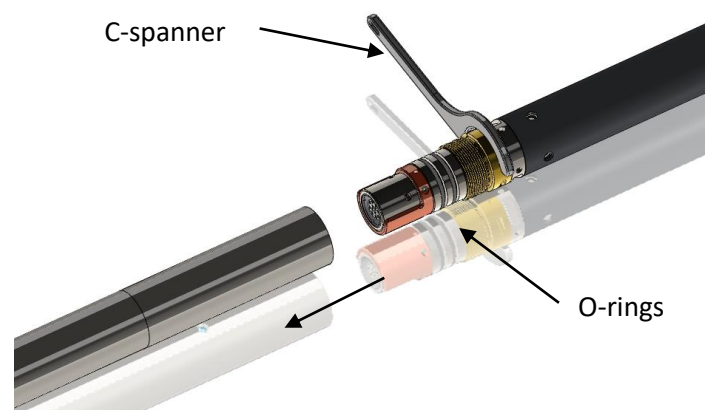

Figure 3-1 C-spanner and O-rings of QL connection

The following example of a QL40-ABI, QL40-GAM and QL40-GO4 (Figure 3-2) describes how to replace the QL40-ABI with a QL40-Plug in order to run the QL40-GAM sub stand-alone.

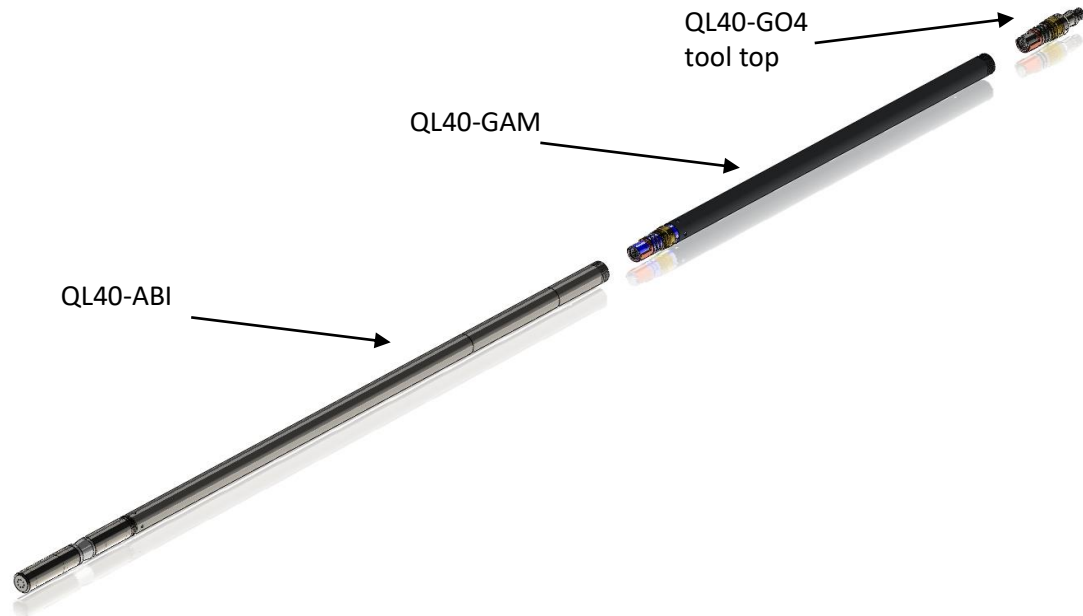

Figure 3-2 Tool stack example

To remove the QL40-ABI bottom sub attach the C-spanner to the thread ring as shown in Figure 3-3, unscrew the thread ring and remove the QL40-ABI bottom sub.

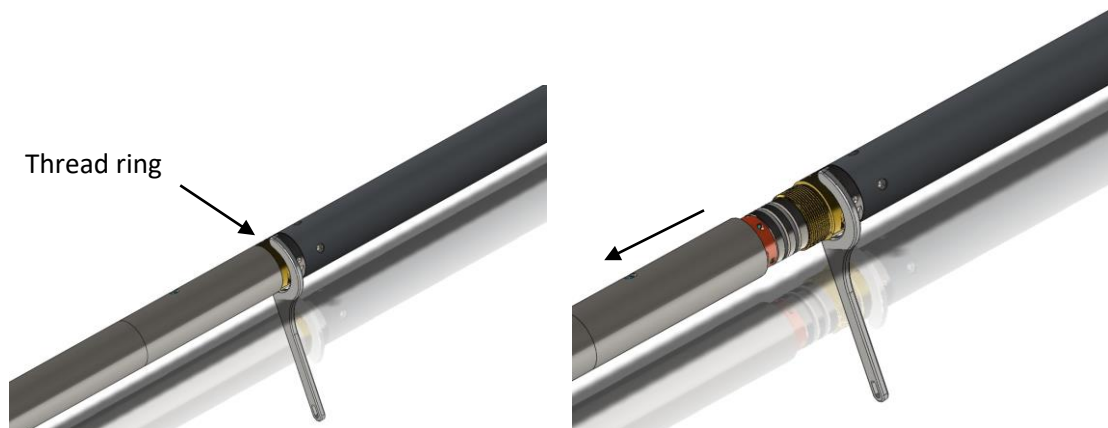

Figure 3-3 Unscrewing the thread ring and removing the bottom sub

After checking the O-ring integrity slip the QL40-Plug over the exposed QL connector (Figure 3-4) attach the C-spanner and screw the thread ring until the plug fits tight.



Figure 3-4 Attaching the QL40-Plug

The QL40-GAM can now be run stand-alone (Figure 3-5).



Figure 3-5 QL40-GAM mid sub with tool top and bottom plug

4 Operating Procedure

4.1 Preliminary note

Acoustic televiewer image quality is highly dependent upon tool centralisation.

One set of centralisers is supplied with the QL40 ABI and is suitable for all tools with an external diameter of 40mm. The standard assembly comprises upper and lower mounting rings with sets of 3", 5" and 6" bowsprings. Two C spanners are provided for tightening the locking ring. Bowsprings for other borehole diameters are available on request.

The following points relating to the use of centralisers should be considered:

The centralisers should be fitted before mating the tool with the wireline cable head and should always be fitted from the cable head end to avoid damaging the acoustic window.

The compression ring of the centraliser, i.e. the one that is screwed tight, should always be fixed toward the **top** end of the sonde. This is to avoid catching on a downhole obstruction when winching up.

Use the C spanner to fasten the fixing rings but take care not to cross thread or over tighten them as this could damage the pressure housing

(The weak point of the bowsprings is the welded bearing pin. Take care during assembly as the weld can be broken by reverse bending.)

The QL40 ABI enables inspection behind PVC casing. In this situation, the PVC casing must be properly centred in the borehole and the tool correctly centralised in the casing to obtain satisfactory results.

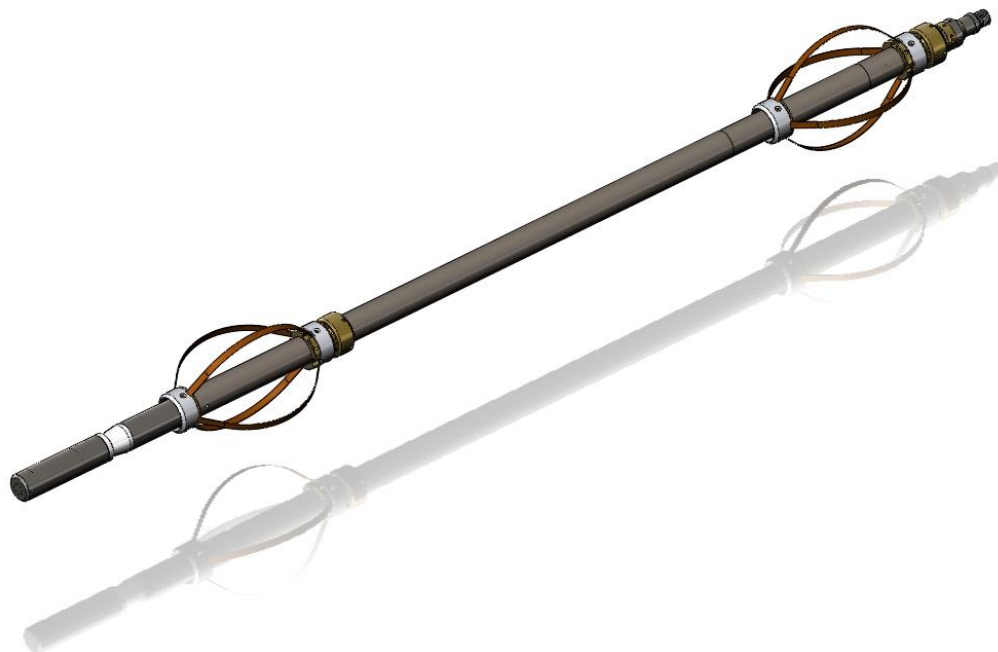

Figure 4-1 QL40 ABI with mounted centralizers.

4.2 Quick Start

Note: Parts of the topics discussed in these sections below assume that the user is familiar with the data acquisition software. Refer to the corresponding operator manuals for more details. Information about assembly and configuration of tool stacks can be found in the same manuals.

1. Connect the tool to your wireline and start the data acquisition software.

2. Select the relevant QL40 ABI tool from the drop down list (Figure 4-2) in the software's **Tool** panel (if your tool is not listed check that your tool configurations file is stored in the designated folder on your computer).

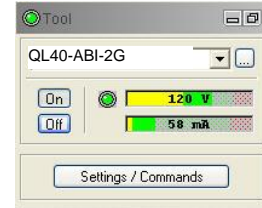

Figure 4-2 Tool panel

3. In the **Tool** panel switch on the tool (click **On** button) and verify that the power indicator shows a valid (green) level. The system goes through a short initialization sequence which sets the default parameters and communication settings held in the tool configuration file. The configuration returned by the tool is also checked during this procedure. (Setup tool communication as explained in chapter 4.5 if error message is displayed.)
4. On the **Tool** panel (Figure 4-2) click the **Settings / Commands** button to configure your tool for open hole/cased hole logging (see chapter 4.3 and 4.4 for details).

5. In the **Acquisition** panel (Figure 4-3) select the sampling mode ("depth" recommended). Click on **Settings** and specify the corresponding sampling rate. Switch on the sampling (click the **ON** button).



Figure 4-3 Acquisition panel

6. Press the **Record** button in the **Acquisition** panel (Figure 4-3), specify a file name and start the logging.

7. During logging observe the controls in the **Telemetry** panel:

- Status must be valid (green light);
- Bandwidth usage in green range;
- Memory buffer should be 0%;
- Number of **Data** increases and number of **Errors** negligible.
- Verify motor status (synchronization) in MChNum browser is valid.
- Do not log too fast! The **Data/sec** parameter must not exceed the speed of the motor rotating the mirror. Check against the **MotSpeed** displayed in the MChNum window.

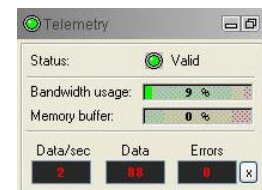

Figure 4-4 Telemetry panel

8. To end the logging procedure press the **Stop** button in the **Acquisition** panel and turn off the sampling (click **OFF** button).

9. In the **Tool** panel power off the tool.

4.3 Tool Communication with OPAL/SCOUT (ALT MODEM)

The telemetry provided through the **OPAL-SCOUT** systems implementing the **ALT MODEM** controls and configures **AUTOMATICALLY** the telemetry settings for any wireline. In case communication status is not valid the user has different options to adjust manually the telemetry settings from the telemetry panel of the dashboard:

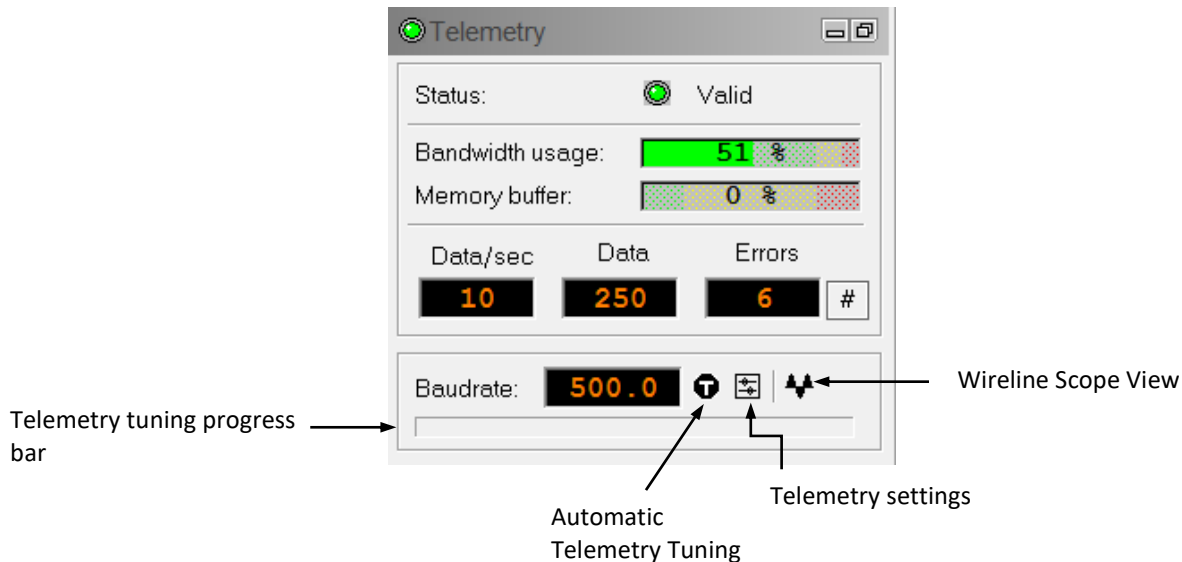

Baud rate:

Indicates the default baud rate or optimal baud rate in kbps found by the system for the selected winch/telemetry scheme

Automatic Telemetry Tuning:

The Tune button  resets the telemetry tuning automatically. This process defines:

- the optimum baud rate for the winch configuration selected
- a transfer function and a filter to re-construct at the surface the shape of the pulse trains distorted by the wireline.

A **progress bar** at the bottom of the telemetry window shows the progression of the telemetry tuning. At the end of the process the baud rate display is refreshed with the optimal baud rate value.

Refer to **Appendix** at the end of this manual for more information on the **advanced telemetry settings**.

4.4 Tool Communication with ALT Logger

The telemetry provided through the ALTLogger is self-tuning. In case communication status is not valid the user can manually adjust the settings. In the **Telemetry** panel of the dashboard click on **Settings** to display the **Configure Tool Telemetry** dialog box (Figure 4-5). A procedure to achieve valid communication is given below:

- Change the **Baudrate** to 41666 kbps.

- Verify that the **Downhole Pulse width** knob is set on 20 (default value). This value is the preferred one and is suitable for a wide range of wirelines. For long wireline (over 2000m), increasing the pulse width could help to stabilize the communication. The reverse for short wireline (less than 500m).
- Set the **Uphole** discriminators in the middle of the range for which the communication status stays valid.
- Increase the **Baudrate**, check the communication status stays valid and the **Bandwidth usage** (in **Telemetry** panel of the dashboard) is below the critical level.
- When **Uphole** discriminators are properly set, store the new configuration as default. The tool should go through the initialisation sequence the next time it is turned on.

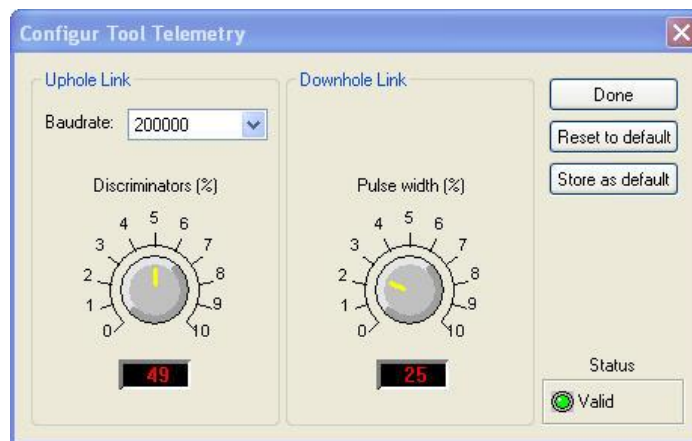

Figure 4-5 Tool communication settings

4.5 Tool Communication with MATRIX

The tool telemetry can be configured through the **Telemetry** panel of the Matrix dashboard. By clicking on **Settings**, the operator has access to the **Configure ALT Telemetry** dialog box (Figure 4-6) providing various controls to adjust the telemetry settings and monitor its current status.

The **Analysis View** displays the current discriminator levels (vertical yellow lines) and a histogram of the up-hole data signal. The scales of the **Analysis View** can be adjusted using the **Vertical Scale** and **Horizontal Scale** knobs and the **linear / logarithmic** scale buttons. The status of the configuration should be flagged as Valid (indicated by the LED being green). In any other case (LED red) the telemetry should be adjusted (we assume a pulse signal is displayed in the analysis view). Click on the **Advanced** button to display additional controls to tune the telemetry.

The Automatic settings option is the preferred mode and should allow the telemetry to be configured for a wide range of wirelines without operator input. For wirelines with a more limited bandwidth, the operator might need to turn off the automatic mode and adjust the telemetry settings manually.

For each wireline configuration, the discriminators (vertical yellow lines) for the **positive** and **negative** pulses must be adjusted in order to obtain a valid communication status (see Figure 4-6) for an example of a suitable discriminator position). There is also the option to alter the **baudrate** in order to optimize the logging speed. The input **gain** can be increased

(long wirelines) or decreased (short wirelines) in order to set up the discriminator levels correctly.

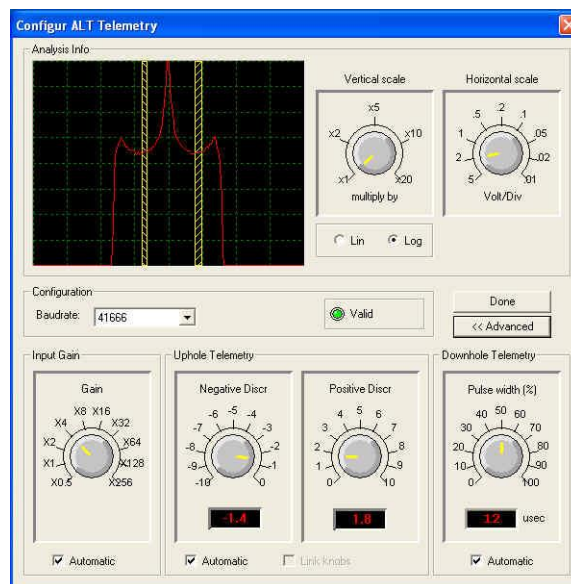

Figure 4-6 Matrix telemetry settings

Once the telemetry is correctly set, store the new settings as default. The tool should go through the initialization sequence in “Valid” status the next time the power is turned on.

4.6 Configuring Tool Parameters

The **Configure ABI Tool Parameters** dialog box (Figure 4-7) can be accessed by clicking on the **Settings / Command** button on the dashboard’s **Tool** panel or by clicking on the tool’s bitmap located in the **Tool Stack Manager** window.

4.6.1 Operating Modes

Three operating modes are possible for recording acoustic images with the QL40 ABI:

- Open hole mode
- Behind PVC mode
- Cased hole mode

4.6.1.1.1 Open hole mode

This record mode is used in open-hole conditions or to record the inner face of a casing.

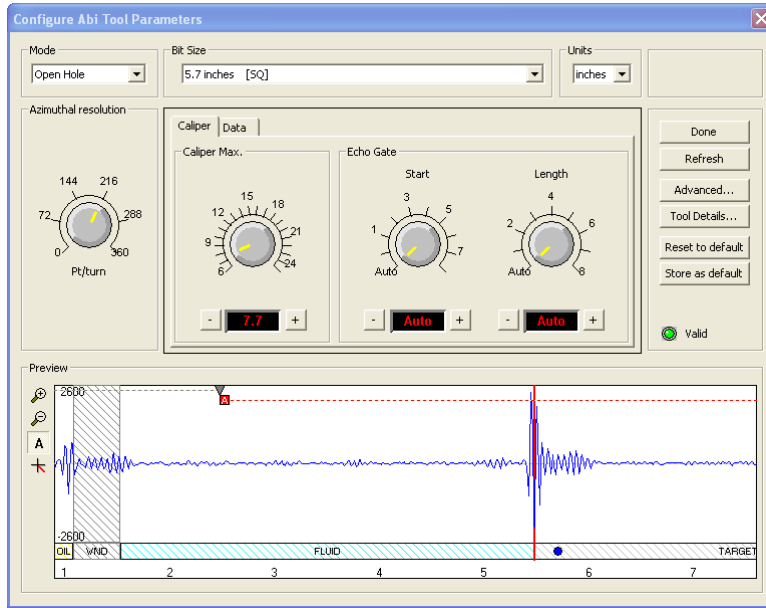

Figure 4-7 Example of tool settings – Open hole mode

When selecting a predefined bit size from the **“Bit Size”** dropdown list, the system configures in an automatic way the most adequate tool settings – azimuthal resolution, caliper max, echo gates - for the selected bit size or borehole nominal diameter. Note that User has always the choice to modify the tool settings as per his own requirements.

Imperial or **metric units** can be used for displaying the wave form preview and for configuring the caliper/echo gate settings.

The **“Open Hole”** mode gives access to two main tabs – **Caliper** and **Data** - for configuring the record:

Caliper tab:

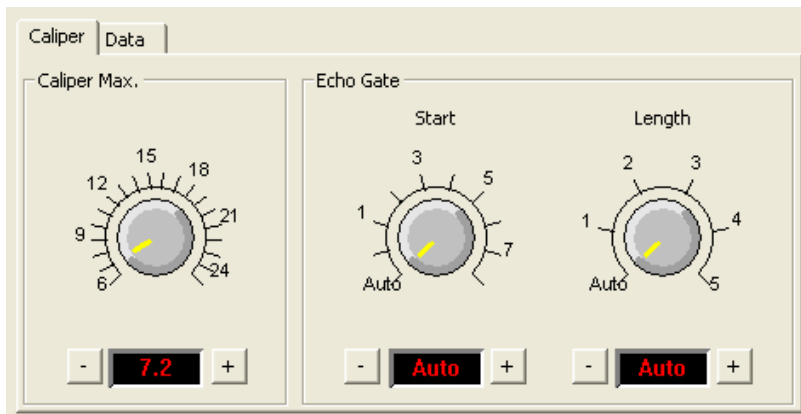

Figure 4-8 Caliper and Echo Gate settings

In the **Caliper** page, the **Caliper Max.** knob (Figure 4-8) controls the extension of the real time preview of the ultrasonic waveform. It must be adjusted for the borehole diameter to investigate to allow detection and recording of the main echo.

Echo Gate settings are set in the “Auto” mode by default. If required, User can define a “**Start**” gate and specify the “**Length**” interval for recording the reflected echo. The tool firmware will pick up the strongest amplitude in the signal train within the Echo Gate and records amplitude and tavel time of the borehole echo.

Note that the **Echo Gate** settings can also be adjusted interactively in the waveform preview.

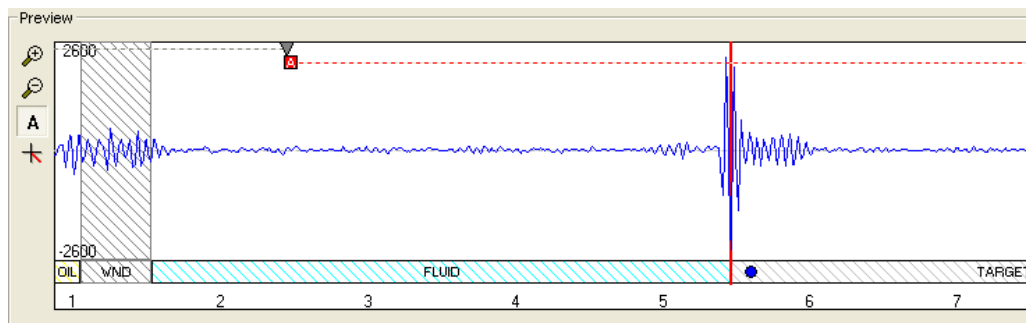



Figure 4-9 Waveform preview - Echo gate Automatic setting

For the open hole mode, the waveform preview allows the user to adjust the limits of two gates – the **Acoustic Window gate** and the **Echo Gate**. The Acoustic Window is represented by a grey dashed line while the Echo Gate is shown as red dashed line.

The Acoustic Gate allows determination of the tool’s acoustic window reflection time.

The **Echo Gate “Start”** limit can be determined automatically or adjusted interactively in the preview. Square and triangle symbols indicate whether the limit of the “**Start**” gate is automatically set (square symbol - ) or if the user can adjust the limit with the mouse cursor (triangle - )

Three modes are supported to set the **Start** time of the Echo Gate - To toggle from one mode to another **right click** on the square or triangle symbol.

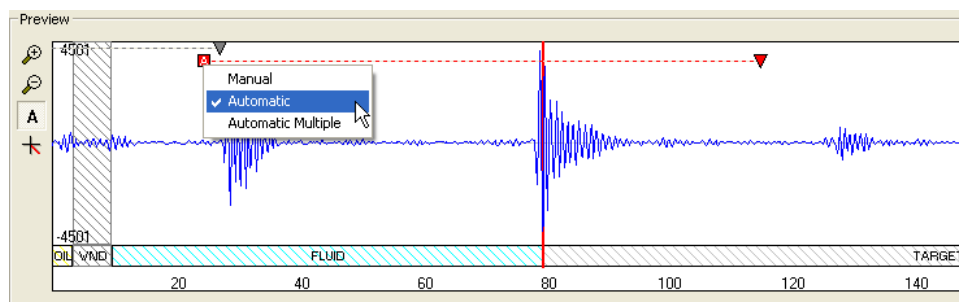

Figure 4-10 Toggling between Echo Gate detection modes

- **Automatic:** the system will automatically detect and record the highest amplitude occurring after the Acoustic Window Gate and the upper limit of the Echo Gate (Figure 4-11). Automatic is the recommended setting.

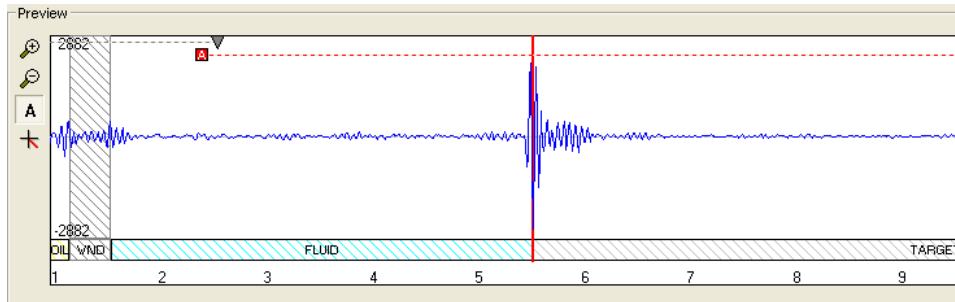

Figure 4-11 Start gate set in automatic mode

- **Automatic Multiple:** the system will automatically adjust the start time of the Echo Gate so that the first multiple of the Acoustic Window reflection is skipped. This setting is useful for large diameter boreholes when the amplitude of the first multiple of the Acoustic Window reflection is higher and arrives earlier than the echo from the borehole wall (Figure 4-12).

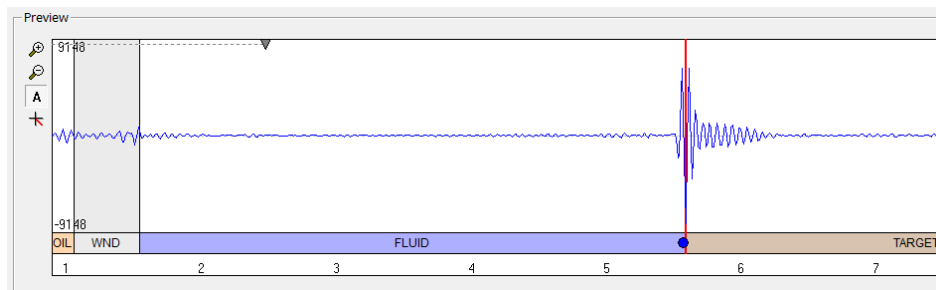

Figure 4-12 Start gate set in automatic multiple mode

- **Manual:** Manual adjustment of the Echo Gate start time is useful to exclude noise with amplitudes higher than the formation signal (e.g. exclude the reflection from the inside of a PVC casing) – (Figure 4-13).

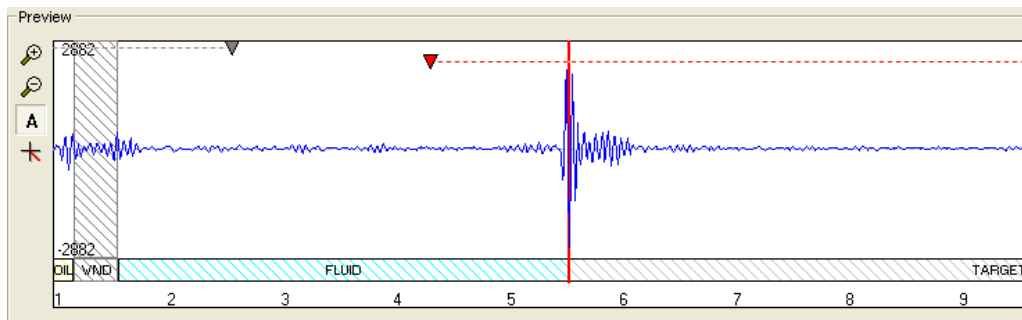

Figure 4-13 Start gate set in manual mode

Interactive adjustment in the waveform preview of the Echo Gate **Length** is also possible. It could be useful when multiple reflections with large amplitudes arrives towards the end of the gate period (e.g. exclude Acoustic Window reflection multiples when logging in soft formations).

To toggle the Echo Gate **Length** from the automatic to the manual mode, place your cursor at the right end of the red dashed line to display the double arrows symbol. Drag then the length limit to the desired position on the wave form preview.

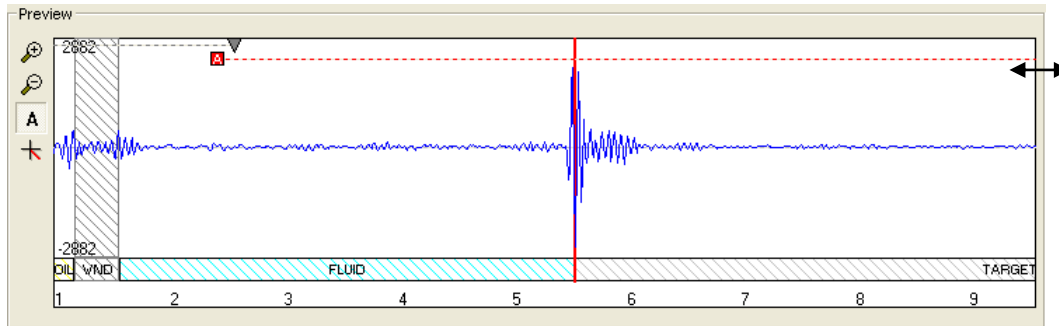

Figure 4-14 Toggling the Echo Gate Length between automatic and manual mode

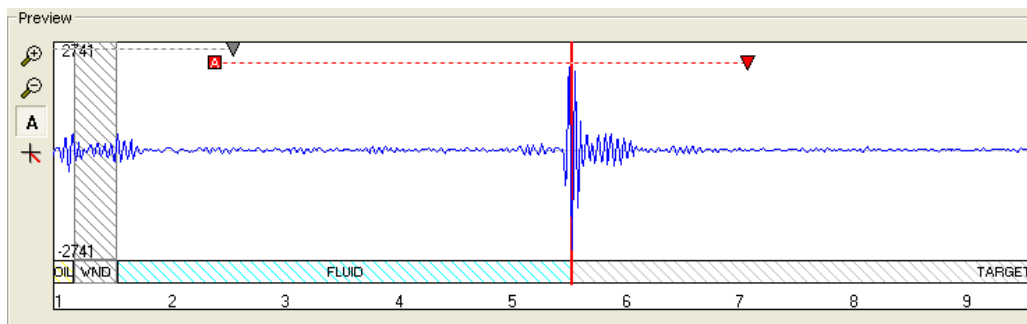

Figure 4-15 Echo Gate Length set in manual mode

To toggle the Echo Gate **Length** from manual to automatic mode, right click on the corresponding triangle symbol.

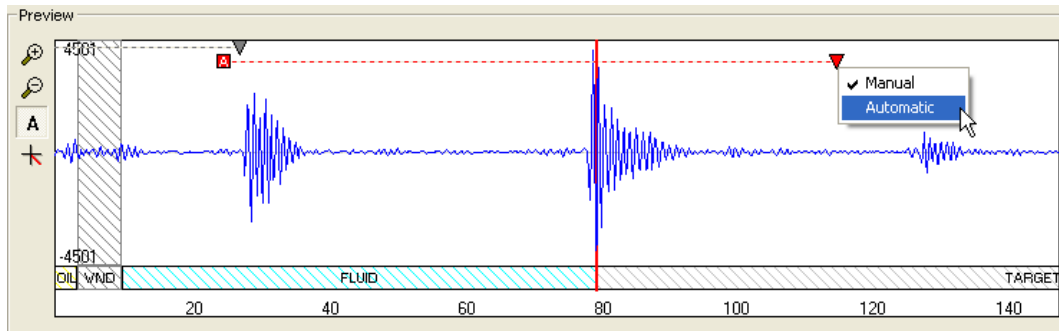

Figure 4-16 Toggling the Echo Length setting from manual to automatic

Data tab:

Figure 4-17 Data record options for the Open hole mode

The **“Target/Formation”** record option must always be checked. If unchecked, no acoustic image will be recorded and the warning message below will be displayed.

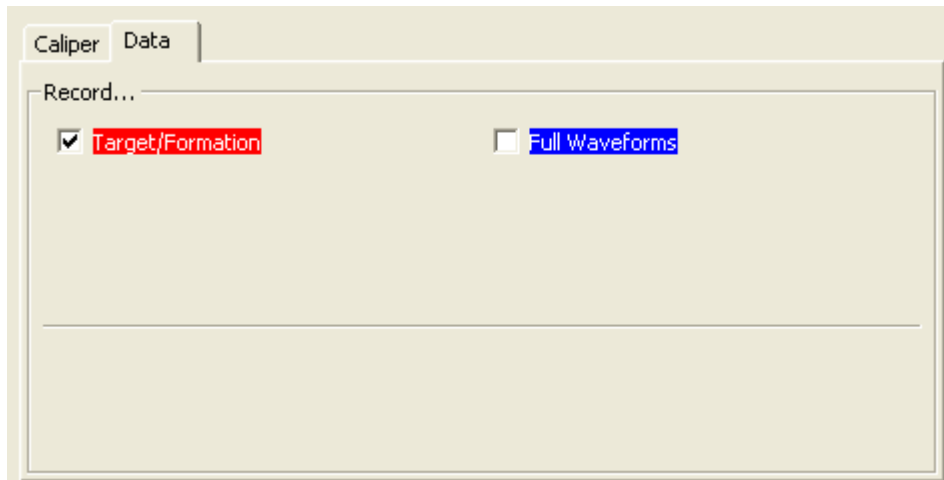
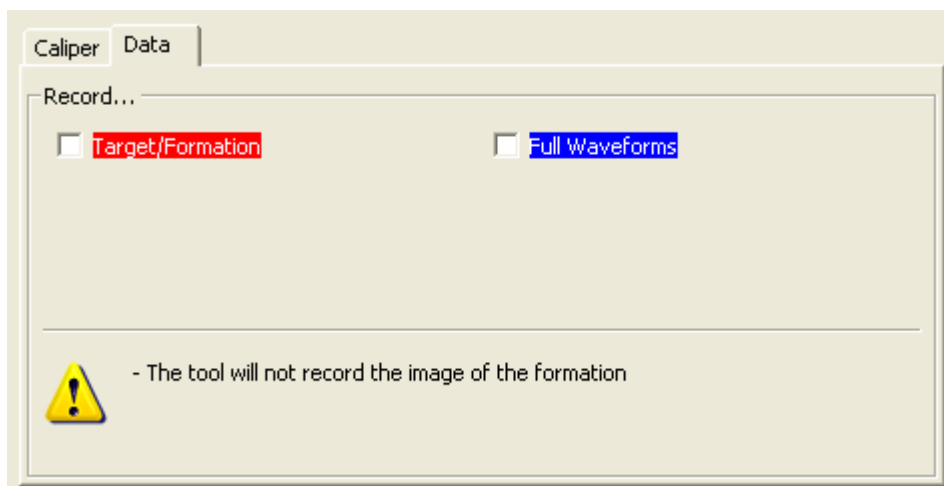

Figure 4-18 Warning message when Target/Formation record is not checked

For diagnostic purposes or advanced processing, the **“Full Waveforms”** record option can be activated. The system will record the complete ultrasonic waveform shown in the preview window.

Note that recording the ultrasonic waveform will affect the telemetry performance and will slow down the logging speed.

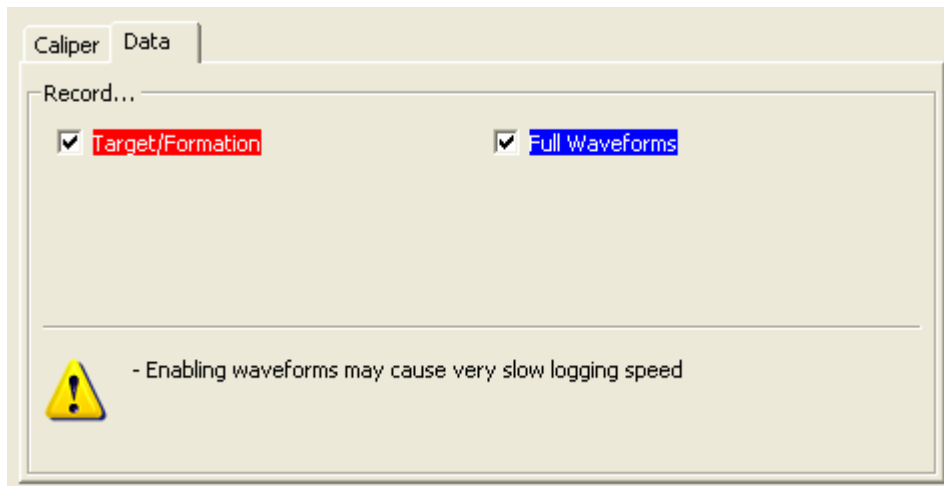

Figure 4-19 Full Waveforms record option selected

4.6.1.1.2 Behind PVC Mode

The “Behind PVC” mode is used in PVC cased boreholes. The main purpose is to log the borehole wall image located behind a PVC casing.

The algorithms implemented in the tool firmware detect and record all existing echoes on the ultrasonic waveforms. The detected echoes are then sorted and interpreted as a reflection from the casing or from the borehole wall (Figure 4-20).

Remind that for such application, the PVC casing must be properly centred in the borehole and the tool correctly centralised in the casing to obtain satisfactory results.

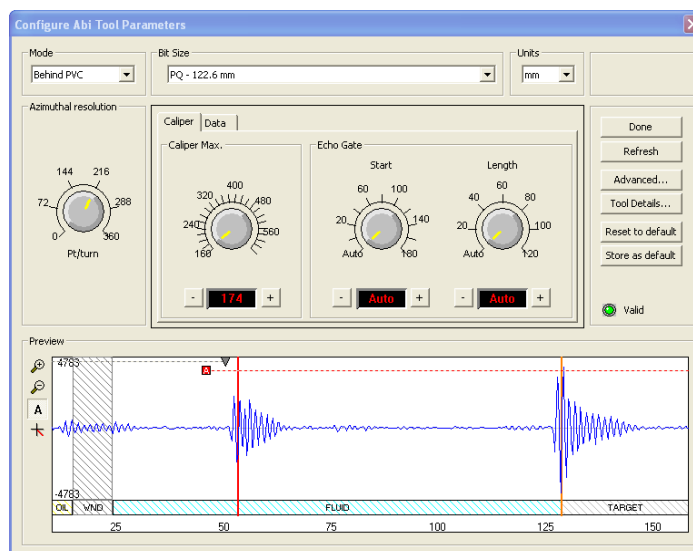

Figure 4-20 Behind PVC settings – automatic settings

The “Behind PVC” mode gives access to two main tabs – **Caliper** and **Data** - for configuring the record:

Caliper tab:

The caliper settings described in section 4.5.1.1 are applicable for the “Behind PVC” mode.

Mainly two major echoes are detected on the waveform preview. The first one is the reflected echo from the inner side of the casing. It is highlighted by the red vertical line. The second reflected echo, corresponding to the borehole wall, is highlighted by the orange vertical line.

Data tab:

Figure 4-21 Data record options for the Behind PVC mode

By default, the system records both the PVC and the Target/Formation images.

The **“Target/Formation”** record option must always be checked. If unchecked, no acoustic image from the borehole wall will be recorded.

Option is given to the user to record or not the image of the inner face of the PVC casing. Recording the PVC image might be interesting to check the casing integrity or for looking at eventual encrustations.

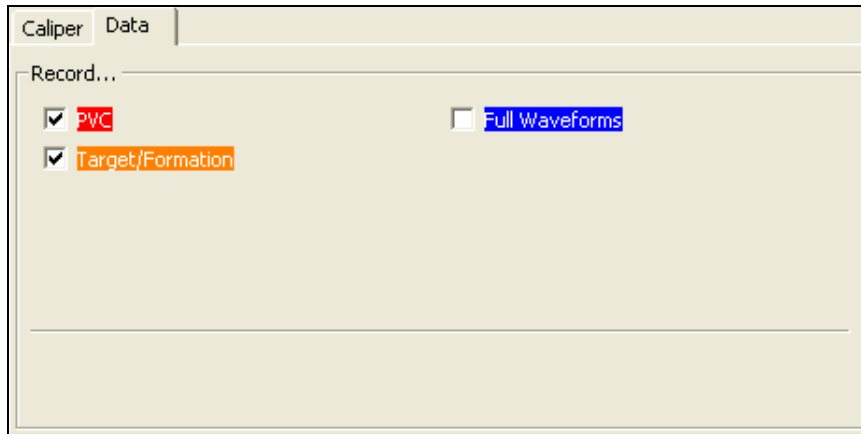
For diagnostic purposes or advanced processing, the **“Full Waveforms”** record option can be activated. The system will record the complete ultrasonic waveform shown in the preview window.

Note that recording the ultrasonic waveform will affect the telemetry performance and will slow down the logging speed.

4.6.1.1.3 Cased hole mode

This acquisition mode is used to perform casing thickness measurements and corrosion evaluation in steel casings.

The operator will need to select from the dropdown casing list the nominal specifications of the casing under investigation (Figure 4-22).

When selecting a predefined **“Casing size”**, the system configures in an automatic way the most adequate tool settings – azimuthal resolution, caliper max, echo gate, thickness, echo gate length - for the casing external diameter and weight chosen.

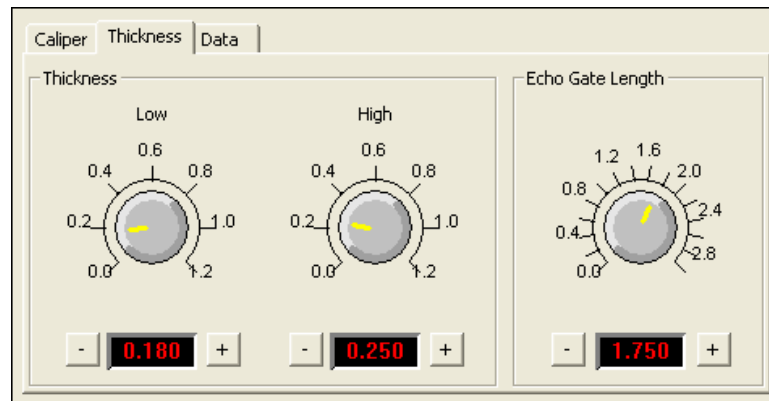

Figure 4-23 Thickness and Echo Gate Length settings

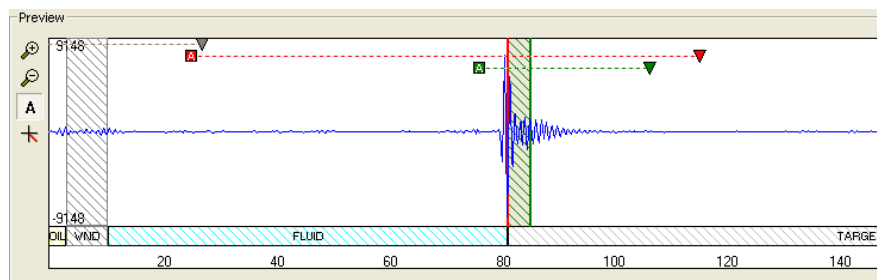

Figure 4-24 Waveform preview – Thickness Echo Gate

For cased hole application, in addition to the Acoustic Window and Echo Gates, a third gate - the **Thickness Echo Gate** (green dashed line – Figure 4-24) - is available for which only the end limit is user adjustable. Reduction of the gate length may be necessary if the ringing signal from the casing is superimposed by noise (e.g. multiples of the inner reflection) towards the end of the gate period.

The greyed - green hatched interval overlapping the recorded echo on the wave form preview is representing the casing thickness measured by the system for this specific ultrasonic trace and orientation.

Data tab:

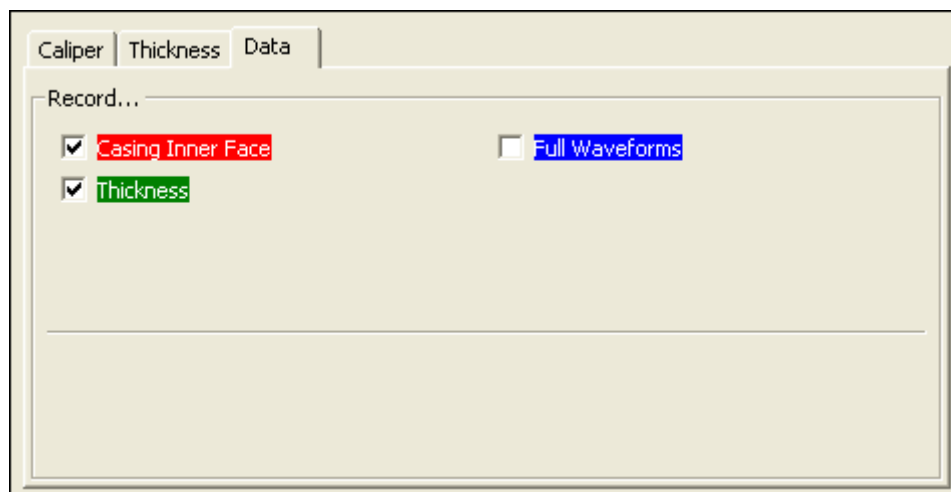

Figure 4-25 Data record options for the Cased hole mode

Option is given to the user to record or not the image of the inner face of the steel casing. Recording the casing inner face image is required for further internal caliper processing and for casing thickness/corrosion evaluation.

For diagnostic purposes or advanced processing, the **“Full Waveforms”** record option can be activated. The system will record the complete ultrasonic waveform shown in the preview window.

Note that recording the ultrasonic waveform will affect the telemetry performance and will slow down the logging speed.

4.6.2 Azimuthal resolution

The azimuthal resolution allows the operator to choose the number of points sampled per revolution of the focusing mirror. Sampling rates of 72, 144, 216, 288 and 360 measured points per revolution are available with the Open Hole Mode. For the Cased Hole Mode the azimuthal sampling rate is limited to 72 and 144 points per revolution.

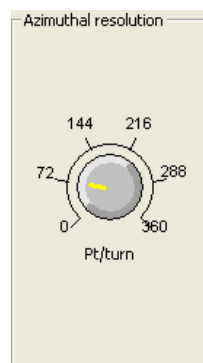





Figure 4-26 choice of azimuthal resolutions

The higher sampling rate can be used for better resolution in larger diameter boreholes but it might be less useful in small diameter hole as it would cause an overlap of sample points. The speed of rotation of the focusing mirror is directly linked to the azimuthal resolution and echo mode chosen.

4.6.3 Additional notes on the waveform preview

Beside the interactive settings of the echo gates, the waveform preview is offering other tools to enhance the display of the ultrasonic trace:

-  Zoom in the vertical scale of the echo amplitude
-  Zoom out the vertical scale of the echo amplitude
-  Set the vertical scale automatically with the best fit for the echo display
-  Display the wave azimuth control knob and scan option

- Theoretical position of the main reflector for the corresponding bit or casing size selected

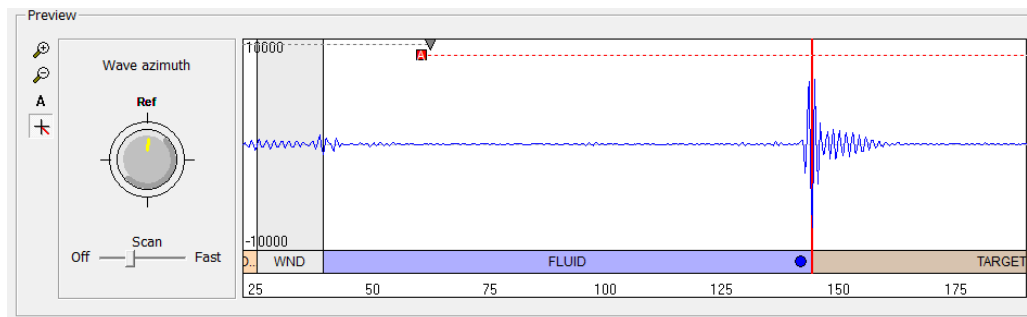

Figure 4-27 Display of the wave azimuth control knob and scan option

The **Wave Azimuth** knob in the full waveform preview box (Figure 4-27) gives the possibility to display the ultrasonic wave train in a preferential direction other than the reference position of the mirror.

The preview of the full waveform of the received signal is generated at the position indicated by the **Wave Azimuth** control knob. By turning the control knob, a different position relative to the tool internal reference side can be chosen.

To turn on an **automatic scan** move the slider bar handle from the **Off** position towards **Fast**. In that case the azimuthal scan position will continuously change with the azimuthal step increasing if the slider position is set towards **Fast**.

4.6.4 Advanced Settings

By clicking on **Advanced** in the “Tool Parameters” dialog box (Figure 4-28) the operator can edit the “Fluid and Casing velocity” constants to convert the acoustic travel time from μs to metric or imperial units. The default values are 1480 m/s for the fluid velocity and 5850 m/s for the steel velocity.

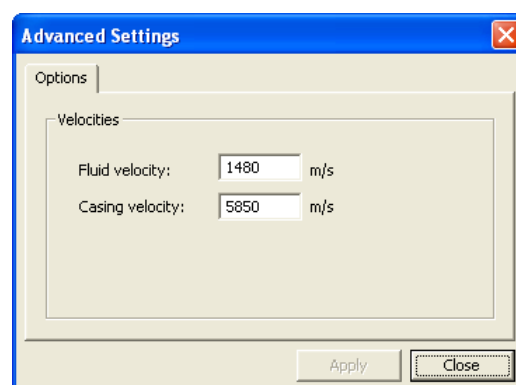

Figure 4-28 Advanced settings

4.6.5 Tool details

By clicking on the **Tool Details** button in the **Configure ABI Tool Parameters** dialog box four tabs (Figures 4-29 to 4-32) become available summarizing tool serial number, acoustic head details, deviation sensor model and analog front end. If necessary, newer tool firmware versions can be uploaded. The upgrade procedure will be explained in a later chapter.

Note: All the information displayed in the following dialog boxes can't be edited

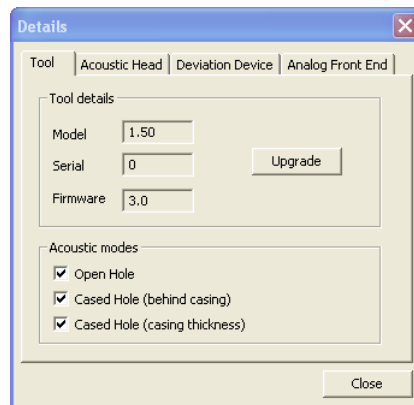

Figure 4-29 Tool details

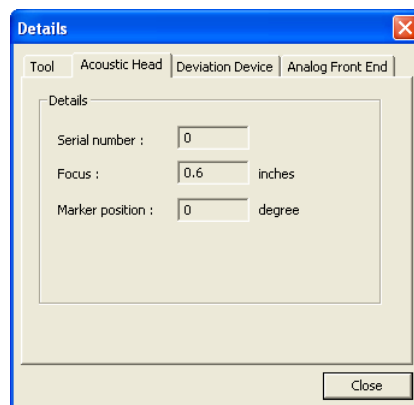

Figure 4-30 Acoustic head details

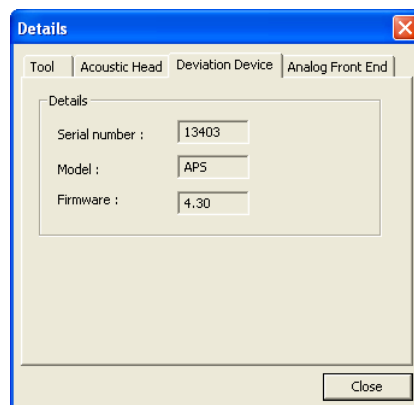

Figure 4-31 Deviation sensor details

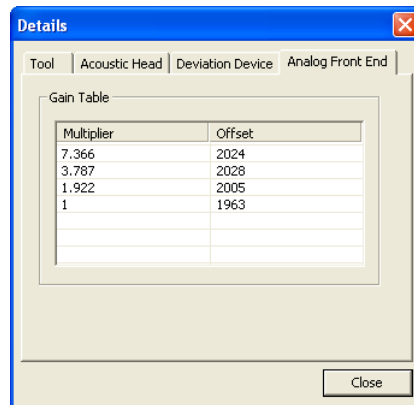

Figure 4-32 Analog Front End

4.7 Recorded Parameters and Browsers

4.7.1 Recorded parameters

The following data channels are recorded by the tool:

TravelTime (1 st echo):	Two Way Traveltime 1 st echo - μ sec
Amplitude (1 st echo):	Amplitude 1 st echo (NM = North Magnetic, HS = High Side)
TravelTime2 (2 nd echo):	Two Way Traveltime 2 nd echo - μ sec
Amplitude2 (2 nd echo):	Amplitude 2 nd echo (NM = North Magnetic, HS = High Side)
ThicknessTTime:	Two Way Traveltime within casing - μ sec
Score:	Quality Index for thickness signal detection
Azimuth:	Azimuth from Magnetic North – deg
Tilt:	Inclination from verticality – deg
Roll:	Tool relative bearing calculated from accelerometers - deg
Mroll:	Tool relative bearing calculated from magnetometers – deg
Magn.Field:	Magnetic field surrounding the borehole - μ T
Gravity:	Absolute value of the Earth gravity – g
Orientation:	Orientation diagnostic code
WndTime:	Two way traveltime of acoustic window reflection – μ sec
WndAmpl:	Amplitude of acoustic window reflection
System Status	General system diagnostic code
VTool:	Tool head voltage - V
V12:	Internal tool voltage - V
RTHead :	Temperature sensor resistance - ohms
TCPU :	CPU temperature - °C
T APS:	Temperature inside the deviation sensor - °C
T Head :	Acoustic head internal temperature - °C
MotSpeed:	Motor - Speed of rotation – rps
Motor:	Diagnostic code
Motor Period:	Time for a single revolution – sec

4.7.2 MChNum Browser Window

Figure 4-33 and 4-34 show typical examples of the numerical values displayed in the MChNum browser window during logging.

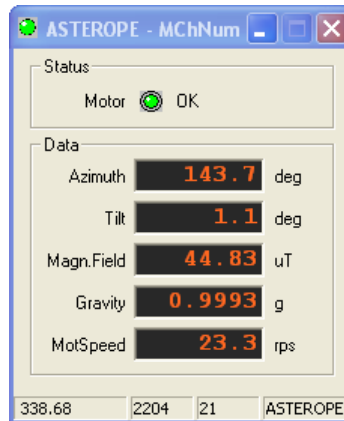

Figure 4-33 MChNum browser display – example 1

Motor:	Motor synchronisation status
Azimuth:	Azimuth from Magnetic North - deg
Tilt:	Inclination from verticality - deg
Magn.Field:	Magnetic field surrounding the borehole - μ T
Gravity:	Absolute value of the earth gravity - G
MotSpeed:	Motor - Speed of rotation – rps

To display additional parameters in the MChNum browser right click on the MChNum browser title and select **Display Options** to add/remove channels and Led status.

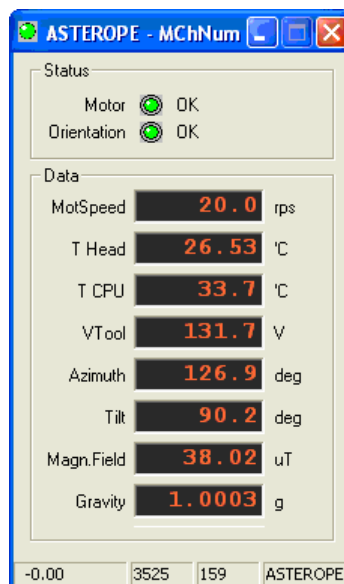

Figure 4-34 Multi Channel Browser for Numerical Data (MChNum) displaying additional channels

4.7.3 Surface Image Browser Window (AbiSurfacelmg)

The system returns an unwrapped image of the borehole wall based on the caliper and amplitude values of the recorded acoustic signal (Figure 4-35). The left column shows the caliper image and the right column the amplitude image.

These images consist of a succession of variable density colors. By double clicking on the log titles Minimum and Maximum scale values may be adjusted to enhance the log appearance.

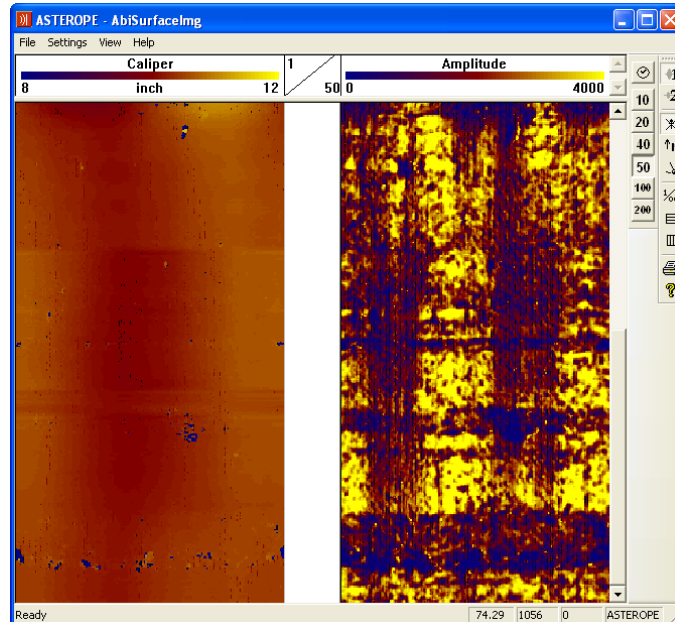

Figure 4-35 ABI Surface Image browser window

Note that the displayed units for the caliper log can be converted to either metric or imperial units via the menu bar's **Settings** option or by double clicking on the log title.

Echo selection :





-  Echo1 is displayed (borehole wall or inner side of the casing)
-  Display Echo2 (borehole wall behind a PVC casing)

Image orientation:

-  Image is non-oriented
-  Orient image to magnetic North
-  Orient image to High Side of the tool

There are two modes of tool data orientation: orientation to High Side and orientation to North. Orientation to High Side is used in inclined boreholes when magnetometers data are unavailable (for example in a cased hole).

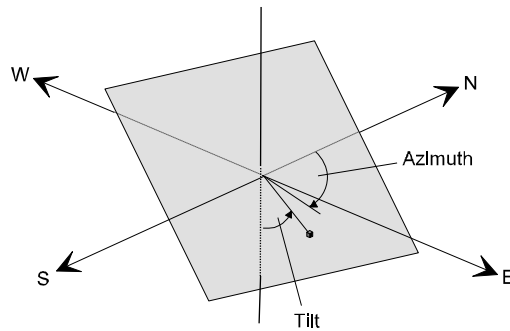

Figure 4-36 Orientation to Magnetic North

Vertical scales and grids:

- 10 Depth mode display and pre-defined depth scales
- 20
- 40
- 50
- 1/100 Operator defined depth scales, interval spacings and settings
- Time mode display

4.7.4 Thickness Image Browser Window (AbiThicknessImg)

In Cased Hole Mode, the ABI Thickness browser displays on the left column an unwrapped color coded image of the **casing thickness** processed by the system (Figure 4-37). The right column is a color-coded image of the **score**. The **score** is a **quality index** on the thickness measurement. In a general way, high score values mean high reliability of the thickness measurement and the reverse.

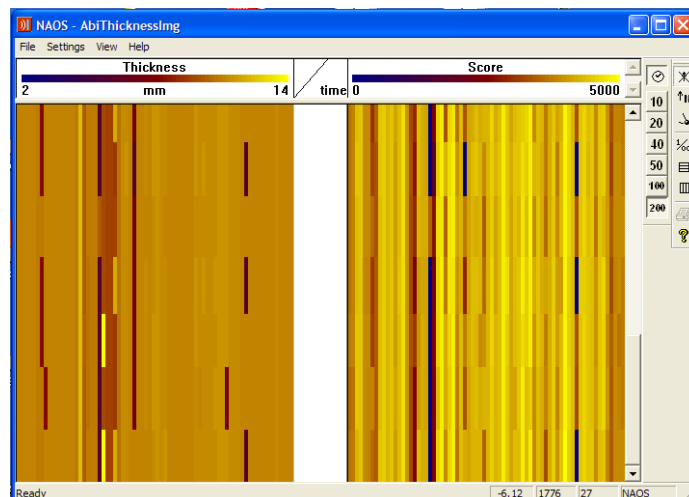

Figure 4-37 ABI Thickness Image

As for the Surface image browser, scales and units of the displayed parameters can be adjusted by double clicking on the log title or from the **Settings** option of the menu bar.

4.7.5 Caliper Browser Window (AbiCaliper)

Caliper browser - Open Hole Mode

The open hole caliper view (Figure 4-38) shows in real-time a cross-section of the acoustic caliper. Scaling, concentric gridding and displayed units are adjustable from the tool bar “Settings” option.

The black circle shows the external limit of the acoustic window.

The red circle is the cross section of the acoustic caliper corresponding to the main reflector detected by the system (borehole wall or inner surface of a casing).

As for the image browsers, the caliper view can be oriented to Magnetic North, High side or displayed without orientation.

During the acquisition, it is possible to centralize the caliper cross section to remove the effect of decentralization of the tool in the borehole.

Clicking the symbol  can do this.

Statistical caliper figures (Min, Max, Average) are displayed on the left side of the dialog box.

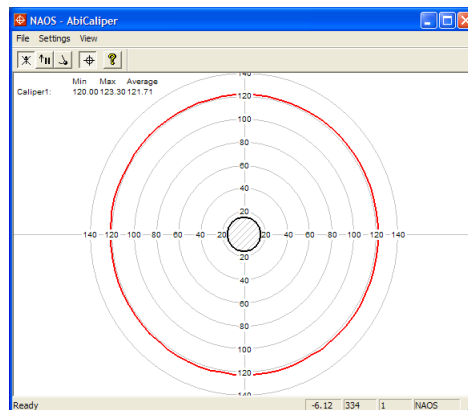

Figure 4-38 ABI Caliper – Open Hole Mode

Caliper browser – Behind PVC mode

The “Behind PVC” caliper view (Figure 4-39) shows in real-time a cross-section of the acoustic caliper of the PVC casing and borehole wall. Scaling, concentric gridding and displayed units are adjustable from the tool bar “Settings” option.

The red circle is the cross section of the acoustic caliper corresponding to the inner side of the PVC casing.

The orange circle is the cross section of the acoustic caliper corresponding to the borehole wall reflection.

As for the image browsers, the caliper view can be oriented to Magnetic North, High side or displayed without orientation.

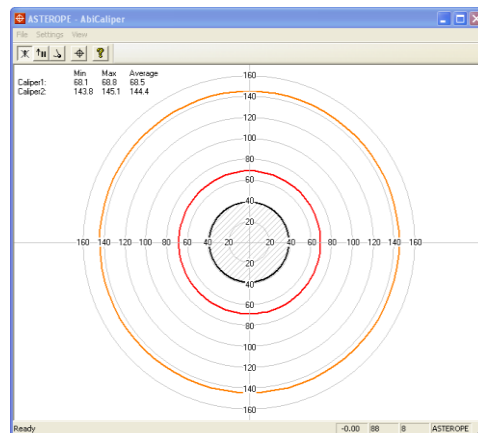

Figure 4-39 ABI Caliper – Behind PVC Mode

Caliper browser - Cased Hole Mode

Cross sections of both of the inner (red circle) and outer (orange circle) surface of the casing are shown in this browser (Figure 4-40), giving a good visualization of the casing thickness in real-time. The space between the 2 circles is filled with the corresponding color coded score values.

Orientation, scaling, concentric gridding and displayed units are adjustable from the menu bar's **Settings** option.

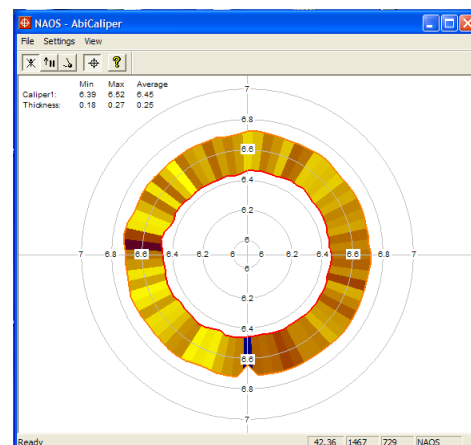

Figure 4-40 ABI Caliper – Cased Hole Mode

5 Performance Check & Calibration

5.1 Mirror rotation

Direction of motor rotation is **clockwise viewed from top of tool** (Figure 5-1):

Placing 2 fingers³ on the acoustic window may check mirror rotation. In time mode, record the 2 finger traces shown⁴ on the Abi surface browser. Remove your right finger from the acoustic window; the corresponding right finger trace on the Abi surface image should disappear.

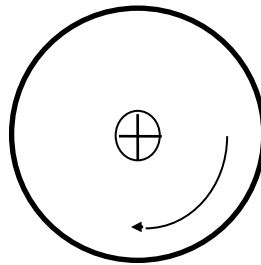

Figure 5-1 Direction of mirror rotation

5.2 Functionality test of the deviation system

5.2.1 Functionality test

The ABI's deviation system is factory calibrated and does not require further calibration. The functionality tests subsequently described have to be done to check that the tool is giving the correct deviation outputs:

To verify inclination at 0° and 90°, position the probe vertical (acoustic head pointing down) for 0° inclination and horizontal for 90° inclination. Note that uphole measurement is possible with the APS544 deviation system as it includes 3 accelerometers. In uphole, the inclination will be between 90° and 180° (probe vertical, acoustic head pointing up).

To verify azimuth accuracy, a good compass and an area free of magnetic materials must be used. Use a compass to orient North with the probe horizontal and verify that the azimuth reading is 0° ± 1°. Repeat the procedure for East, South and West directions.

5.2.2 Rolling test – azimuth and tilt check

Azimuth and tilt could be tested by rotating the tool about its long axis while maintaining both a constant inclination to the vertical, say 15°, and a fixed azimuth. The data imported into WellCAD should show a deviation of the azimuth less than the limit of ±1.5° and a deviation of the tilt less than the limit ±0.5°.

³ Wet your fingers first for a better coupling

⁴ Adjust the amplitude scale to enhance the finger traces

6 Maintenance

Warning: Removing the electronic chassis from pressure housing without prior consultation with ALT will void the tool warranty.

The ABI televiewer is a delicate instrument and should be treated with care at all times. Excessive shock or extreme temperatures should be avoided and the tool should always be transported in its transport case or a similarly cushioned enclosure. Never support the tool on the acoustic head. Experience shows that with attention to these points the QL40 ABI will give several years fault free operation.

The ABI televiewer separates into four basic parts

- The tool top adaptor
- The pressure housing
- The electronic chassis
- The acoustic head.

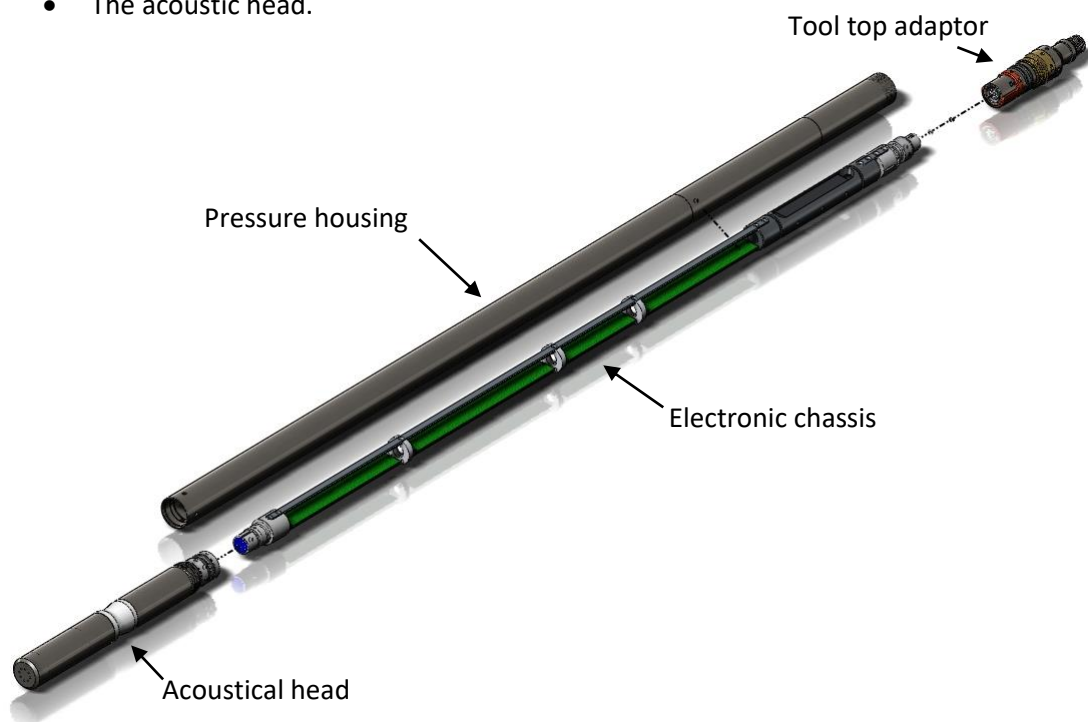

Figure 6-1 ABI and tool top, exploded view

Should it become necessary to open the tool, the tool parts must be separated in the following sequence:

1. Remove the tool top adapter
2. Remove the acoustic head
3. Remove the pressure housing

Disassembly of the electronic chassis from the pressure housing should never be attempted in the field.

6.1 Tool Top Adapter

The tool top adapter provides the connection between wireline cable head and chassis electronics and can be provided to suit 7 conductors, 4 conductors, mono or special wireline configurations. The adapter is fixed by the means of a threaded ring screwed in the pressure housing. To remove the tool top adapter, use the correct C spanners provided with the tool - see picture below (Figure 6-2).

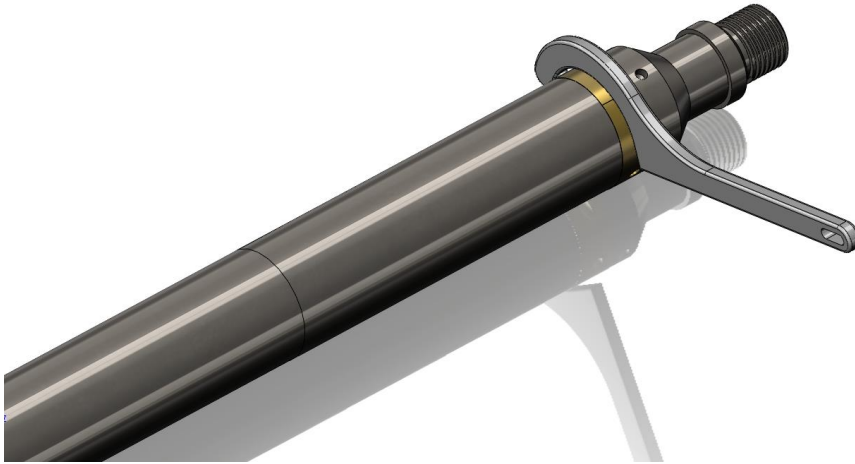

Figure 6-2 Removing the tool top

The wireline cable head socket and tool top adapter connector pins should be checked for cleanliness before each use of the tool. The pin inserts, whether 4 or 7 pin, have a locating mark indicating WL1 or A that should line up with the slot mating with the cable head.

Check O-Ring seals and apply silicon grease before re-assembly. Silicon grease of a similar type to RS Components Ref 494-124 is suitable for this and other O-Ring seals.

(Rem: O-Ring reference for tool top and for the quick link 40 is AS215 26,57 x 3,53 Viton Shore 75)



Figure 6-3 QL40-GO4 Tool top adaptor



Figure 6-4 QL40-G07 tool top adaptor



Figure 6-5 QL40-G01 tool top adaptor

6.2 Acoustic head

Warning: The televiewer acoustic head is extremely delicate and must be treated gently at all times. Any laterally applied force on the end of the head is liable to cause damage!

The acoustic head is attached to the electronic chassis of the sonde by three 2.5mm hex set screws. To remove the entire televiewer head the tool top and pressure housing must first be removed as described below. Slacken off the fixing screws and slide the televiewer head off the connector. The connector has a keyway to locate the head with the correct orientation.

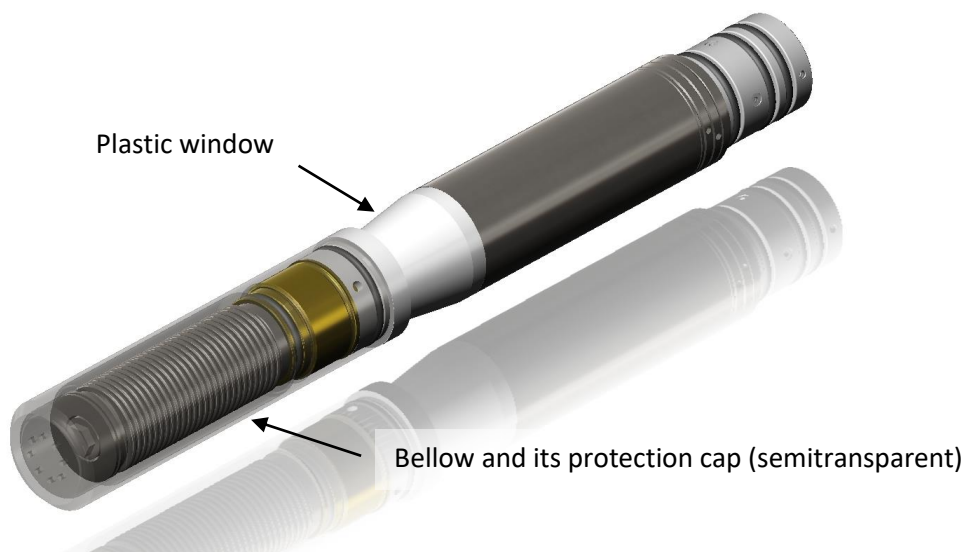

Figure 6-6 Acoustical head

Re-assembly is the same procedure in reverse order, but taking care not to force the head on to the connector. This will result in bent or broken connector pins! Check all “O” ring seals (Orings AS215, 26.57x3.53, viton, shore 75) and apply silicon grease to them.

The acoustic head needs to be properly maintained to give the best image results.

Note the following points:

- Check that there are no air bubbles visible in the acoustic window. Air can separate out of the oil filling the head, notably after airfreight at low pressure, and can also work its way out of the inner parts of the motor. The presence of air in the head is indicated by a spotty image or streaking. These effects may come and go as the orientation of the tool is changed.
- Check that there is not excessive lateral movement on the end of the head. The bellows cap must be screwed up against the acoustic window but not excessively tight.
- If the acoustic signal is lost, check for isolation between pins A&B in the acoustic head. The most common reason for loss of signal is the cutting of the signal coax to the transducer in the head. This happens when the window is rotated relative to the head body. Check with a gentle twisting motion that the window does not rotate more than a degree or two relative to the tool body.

- At very low temperatures the oil in the acoustic head becomes viscous and this may prevent the mirror from rotating. In this case keep the tool and head warm before use.

6.2.1 Cleaning the acoustic head bottom section

The bottom section of the televiewer assembly houses a pressure compensating bellows that must be free to move. For this reason the bellows cover is removable to allow cleaning of the exterior of the bellows. The interior of the bellows and main body of the televiewer head is oil filled. Both, the end of the bellows cover and its side wall, have holes to allow pressure equalization, and these holes must be kept clear. The bellows cover is threaded at the top end and held by a screw thread on the main body below the nylon window. The cover should only be **hand tightened**.

Keep the bellows section clean. This will prevent the deterioration of glue seals and the bellows itself. Grit lodged in the folds of the bellows can cause perforation if left over a period of time.

When removing the cover, it is important to **hold the nylon mirror section only**, which is locked integrally with the main tool, while unscrewing the cover. Wrenches must **NOT** be used (Figure 6-7 and Figure 6-8).

Warning: Any Rotation of the nylon section relative to the main tool pressure housing will result in damage to the head and probable tool failure.

The necessity for cleaning will depend on the borehole fluid and borehole conditions. The bellows should only be cleaned when the sonde was used in heavily contaminated fluids, i.e. heavy muds or sediments, or when the fluid is known to be corrosive. In this case it is important to clean deposits off the bellows where it is glued to the flanges at either end. The bellows wall is thin and can become perforated if allowed to corrode.

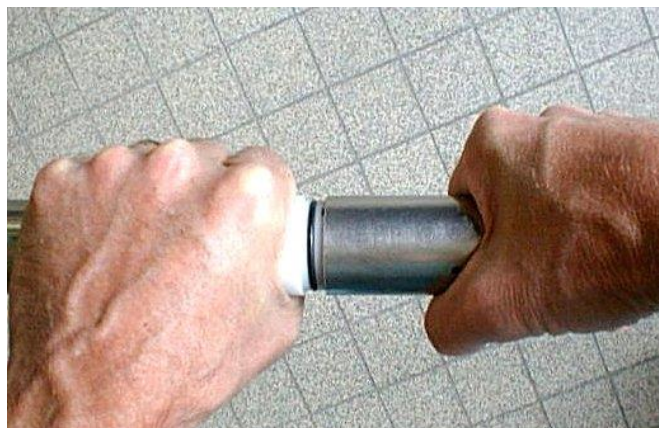

Figure 6-7 Unscrewing the bellows cover



Figure 6-8 Bellows cover removed

6.3 Pressure Housing

The main pressure housing is locked on to the televiewer head by four 2.5mm hex cap screws. After removal of the tool top, the pressure housing can be removed after undoing these screws. When separating the two parts, place the tool on suitable stands, grip the pressure housing with one hand and the acoustic head close to the joint with the other and apply a straight pull. During re-assembly extreme care should be taken not to over tighten the fixing screws which may shear off if overloaded!

The outside of the pressure housing is marked with a Y symbol to indicate the position of the Y axis vertical and upward. The purpose of this is to simplify tool checking.

When re-assembling the pressure housing make sure that the reference mark is correctly aligned with the upper side of the deviation sensor.

6.4 Upgrading ABI firmware

In accordance with the ALT policy of continuous development the ABI has been designed to allow firmware upgrades. The current version of firmware installed in a tool may be verified in the Tool Details window opened from the Tool Settings dialogue box.

Firmware upgrade procedure is as follows:

1. Checking the communication is valid.
2. Upgrading firmware

6.4.1 Checking the communication

1. Connect the ABI tool to your acquisition system.
2. Start ALTLog/Matrix software.
3. In the **Tool** panel select the appropriate tool and turn on the power.
4. In the **Communication** panel, select **Settings**. Check **baud rate** is set to **41666** and **communication status** is **valid** (Figure 6-9 or Figure 6-10).

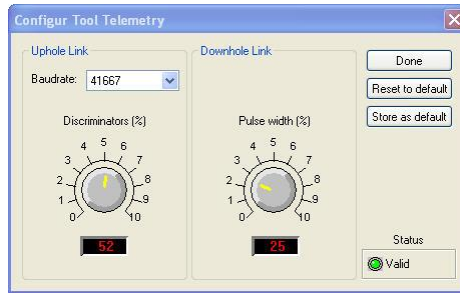

Figure 6-9 Tool communication settings - ALTLog

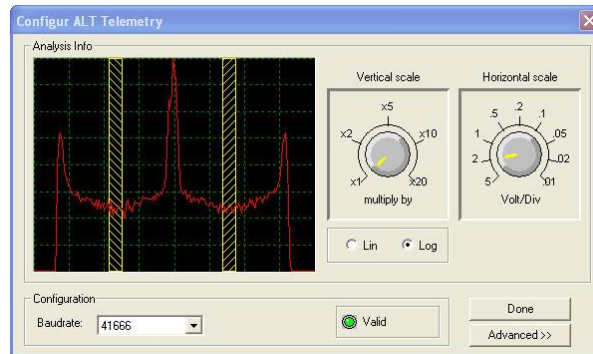

Figure 6-10 Tool communication settings - Matrix

Warning: Telemetry must be tuned properly. Bad communication may abort the upgrade of the firmware!

6.4.2 Upgrading the firmware

In the **Tool** panel, select **Tool settings/commands**. Check that the communication status is valid (Figure 6-11).

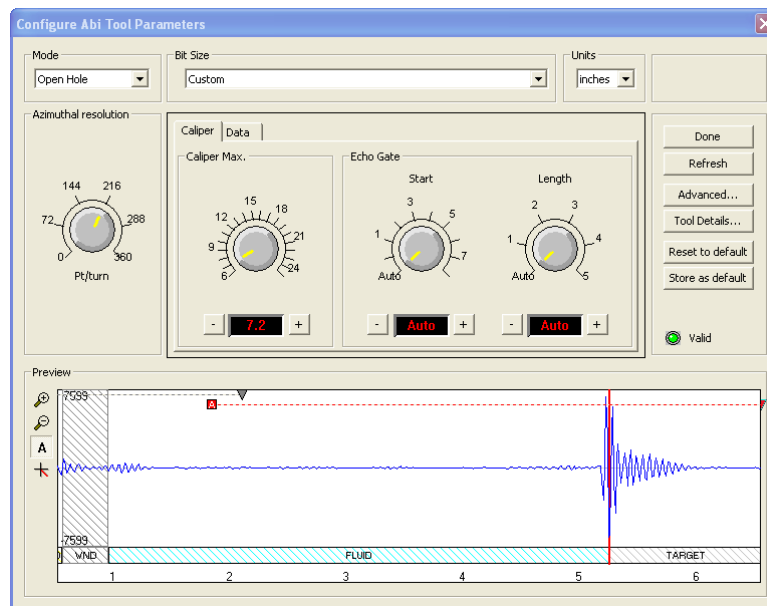

Figure 6-11 Tool settings dialog box

1. Click on **Tool Details**. Note that the firmware version currently in use is displayed in the firmware box. Click on the **Upgrade** button (Figure 6-12).

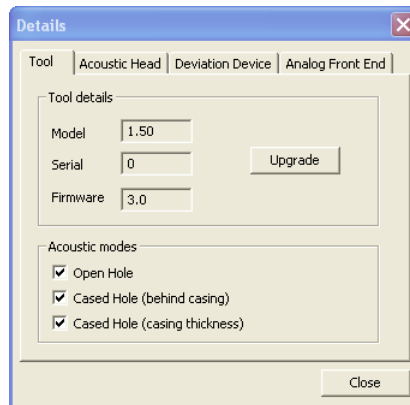

Figure 6-12 Tool Details dialog box

2. The following message will appear (Figure 6-13). Click **Yes** to validate your choice.

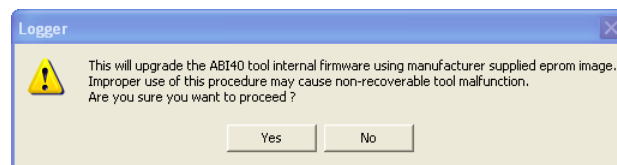

Figure 6-13 Warning Message during firmware upload

3. Select and open the appropriate **.hex** file provided (Figure 6-14). The upgrade will start.

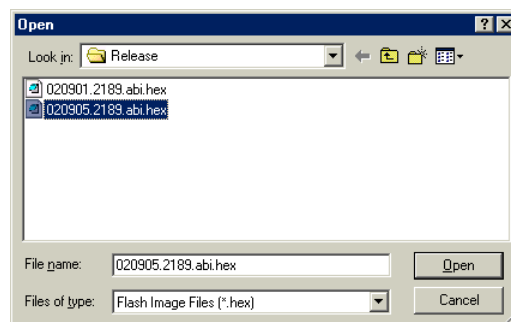

Figure 6-14 Select firmware upgrade

4. During the upgrade procedure, the following message is displayed:

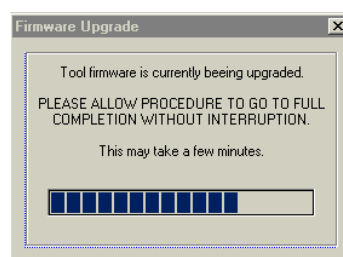

Figure 6-15 Firmware upgrade progress window

5. Once the upgrade has been successfully completed (Figure 6-16), click on **OK** to turn off the tool.



Figure 6-16 Successful upgrade

6. Power on the tool to start the upgraded firmware. Check in **Tool settings/commands** and **Tool details** that the firmware version has been changed with the new one.

Note that this error message (Figure 6-17) will appear at end of the procedure when the tool firmware upgrade has failed or has been aborted. Check tool communication settings.

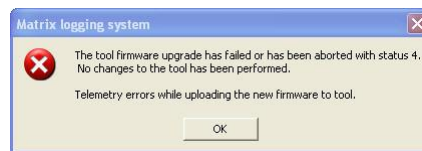

Figure 6-17 Error message

7 Troubleshooting

Observation	To Do
<i>Tool not listed in Tool panel drop down list.</i>	<ul style="list-style-type: none"> - Do you have a configuration file? - Has the configuration file been copied into the ../Tools folder (refer to MATRIX or ALTLog manual about details of the directory structure)?
<i>Tool configuration error message when powering on the tool.</i>	<ul style="list-style-type: none"> - Check all connections. - Adjust the telemetry settings for your wireline configuration (see chapter 4.3 or 4.4) and store the new settings as default. Apply the appropriate tool settings for your logging run (see chapter 4.5).
<i>Tool panel - No current.</i>	<ul style="list-style-type: none"> - Verify that the wireline armour is connected to the logging system. Test your interface cable between winch and data acquisition system. - Verify cable head integrity. - Verify voltage output at the cable head (it should be 120V).
<i>Tool panel - Too much current (red area).</i>	<p>! Immediately switch off the tool !</p> <ul style="list-style-type: none"> - Possible short-circuit (voltage down, current up): Check for water ingress and cable head integrity - wireline continuity. - Verify the interface cable between winch slip ring and data acquisition system is not loose at the connectors. Check for possible source of a short-circuit. - If the above shows no issues, use test cable provided by ALT to verify tool functionality. - If the problem still occurs, please contact service centre.
<i>Telemetry panel - status shows red.</i>	<ul style="list-style-type: none"> - Verify the telemetry settings for your wireline configuration (see chapter 4.3 or 4.4). - If problem cannot be resolved contact support@alt.lu .
<i>Telemetry panel - memory buffer shows 100%.</i>	<ul style="list-style-type: none"> - Indicates that the systems internal memory buffer is full. PC can't receive incoming data streams fast enough. Ensure your PC has enough resources available.
<i>Telemetry panel – bandwidth usage shows 100%. (Overrun error message.)</i>	<ul style="list-style-type: none"> - Set the baudrate to highest value allowed by your wireline configuration. - Reduce logging speed, decrease azimuthal resolution and/or increase vertical sample step.
<i>Telemetry panel - large number of errors.</i>	<ul style="list-style-type: none"> - Verify the telemetry settings for your wireline configuration (see chapter 4.3 or 4.4). - Check bandwidth usage and telemetry error status.

Observation	To Do
<p><i>Permanent No Sync message and red led status in MChNum browser.</i></p> <p><i>Motor stalled and increase of current drawn by the tool.</i></p>	<p>! Immediately switch off the tool !</p> <p>- Stepper motor and mirror synchronization issue. Contact ALT for Acoustic Head service.</p>
<p><i>WellCADimport : acoustic images not imported</i></p>	<p>- Check your WellCAD version (please refer to 1.3 Technical Specifications chapter).</p>
<p><i>WellCAD import : Magnetic North and High Side orientation options not available</i></p>	<p>- Check your WellCAD version (please refer to 1.3 Technical Specifications chapter).</p>

8 Notes on Data Processing

The processing of data acquired with the QL40 ABI and the ABI 40 tools is usually performed using the WellCAD software. We would like to refer the user to the WellCAD user guides for a detailed description of the software's functionality. In particular *Book 3 - Image & Structure Module* should be of help when processing image data.

The following paragraphs will focus on three processes to process traveltime data for which the input of correct units and parameters is crucial in order to obtain accurate results.

8.1 Estimation of Fluid Velocity

The procedure described below outlines the estimation of the borehole fluid velocity which can be used as input for the computation of caliper data described hereafter.

1. From the **Process > Image Module > Image Logs** menu in WellCAD select the **Estimate Fluid Velocity** entry. The corresponding options dialog box will open (Figure 8-1).

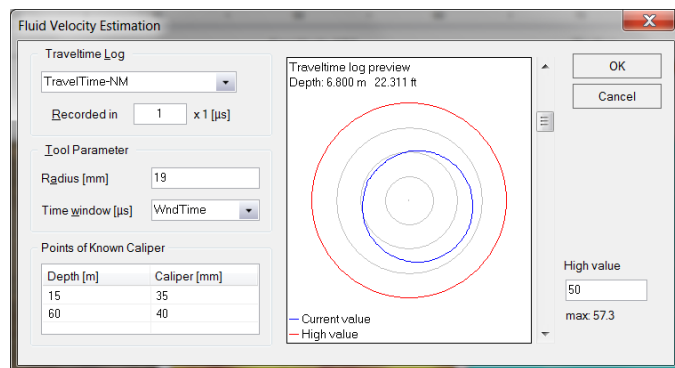
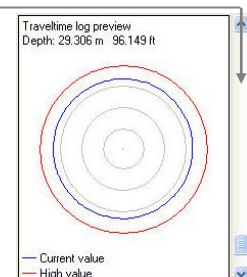
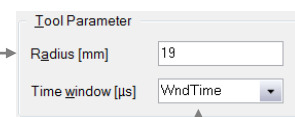
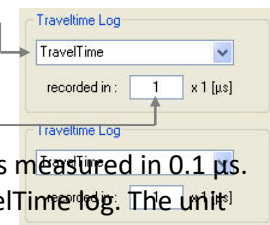

Figure 8-1 Fluid velocity estimation dialog box

2. Select the TravelTime log from the corresponding drop down list in the dialog box.
3. Set the unit the traveltime has been recorded in. For the QL40 ABI or ABI40 tool this manual refers to the unit is $1 \mu\text{s}$. (Older tools measured in $0.1 \mu\text{s}$. You can find out by double left clicking on the log title of the TravelTime log. The unit should show μs . If no unit is shown the measurement was made on $0.1 \mu\text{s}$.)
4. Enter the radius of the acoustic head at the measurement point into the corresponding edit box. For the ABI tools described here a value of 19 mm is appropriate
5. Select the Time window channel *WndTime* which contains the traveltimes from transducer to the acoustic head window and back (has been recorded by your tool along with the other measurements).
6. Use the scroll bar next to the preview of the cross sections generated from the traveltime data and find a depth at which the caliper of the pipe or borehole is known and best reflected by the measurement (for example the nominal internal diameter of casing or the bit size).



- Right click into **Points of known caliper** list and add a new row for a reference point. The depth value will automatically set to the depth of the preview. Enter the known caliper value in [mm].

Depth [m]	Caliper [mm]
22.0962	250
29.3062	250

- Try to set a least a reference point at or near the top and base of the well. Click **OK** when finished. A new log containing the estimated velocity profile will be created.

8.2 Computation of Caliper Data

The following steps summarize the steps to compute radius and caliper data from the acoustic traveltime recorded with your ABI tool:

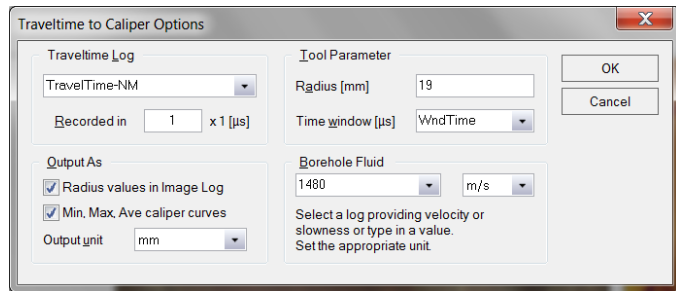
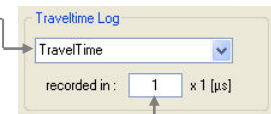

Figure 8-2 Traveltime to caliper conversion dialog box

- Select the **Calculate Caliper** process from the **Process > Image Module > Image Logs** menu. The options dialog box (Figure 8-2) will open.

- Select the TravelTime log from the corresponding drop down list in the dialog box.



- Set the unit the traveltime has been recorded in. For the QL40 ABI or ABI40 tool this manual refers to the unit must be set to 1 μ s. (Older tools measured in 0.1 μ s. You can find out by double left clicking on the log title of the TravelTime log. The unit should show μ s. If no unit is shown the measurement was made on 0.1 μ s.)

- Enter the radius of the acoustic head at the measurement point into the corresponding edit box. For the ABI tools described here a value of 19 mm is appropriate.

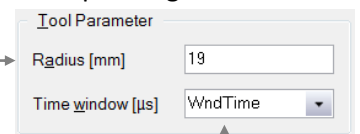

- Select the Time window channel *WndTime* which contains the traveltimes from transducer to the acoustic head window and back (has been recorded by your tool along with the other measurements).

- If you estimated a fluid velocity as described in the paragraph above or have measured values extend the drop down list and select the corresponding log. You can also enter a textbook value manually. Ensure the correct unit has been selected.

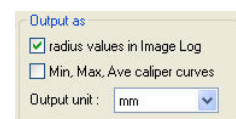
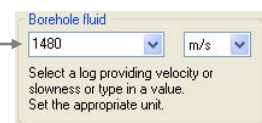

- Select the output options and unit. You can create a new Image Log containing a radius value for each traveltime measurement. In addition you can create Min, Max and Average caliper curves.
- Click on **OK** to close the dialog box and start the computation.

8.3 Calculation of Casing Thickness

If you made measurements in cased hole mode you will get a log containing the traveltime within the steel casing (thickness travel time). The procedure described below summarizes the conversion of the thickness traveltime into a true thickness value.

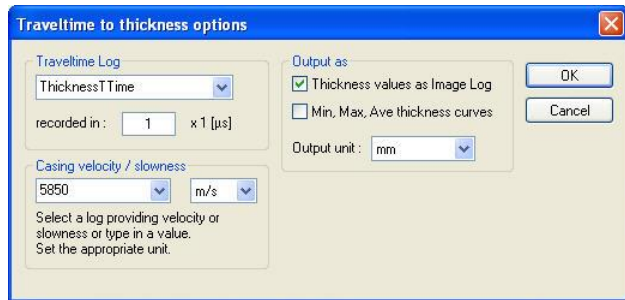

Figure 8-3 Traveltime to casing thickness conversion dialog box

- From the **Process > Image Module > Image Logs** menu in WellCAD select the Calculate Thickness... entry. The corresponding options dialog box will open (Figure 8-3).
- Select the ThicknessTTime log from the corresponding drop down list in the dialog box.
- Set the unit the thickness traveltime has been recorded in. For the QL40 ABI or ABI40 tool this manual refers to the unit must be set to 1 μs . (Older tools measured in 0.01 μs . You can find out by double left clicking on the log title of the ThicknessTTime log. The unit should show μs . If no unit is shown the measurement was made on 0.01 μs .)
- Enter the velocity of sound in steel into the corresponding edit box. A typical value for steel is 5850 m/s. If you have a velocity profile available in a log extend the drop down list and select the corresponding channel.
- Choose the output option and unit. The thickness values can be given as a Image Log with one thickness value for each traveltime thickness measurement and as curve of the minimum, maximum and average thickness determined.
- Click on **OK** to close the dialog box and start the computation.

9 Appendix

9.1 Tool Communication with OPAL/SCOUT

The telemetry provided through the OPAL-SCOUT systems implementing the ALT MODEM adapter is self-tuning. In case communication status is not valid the user has different options to adjust manually the telemetry settings from the telemetry panel of the dashboard:

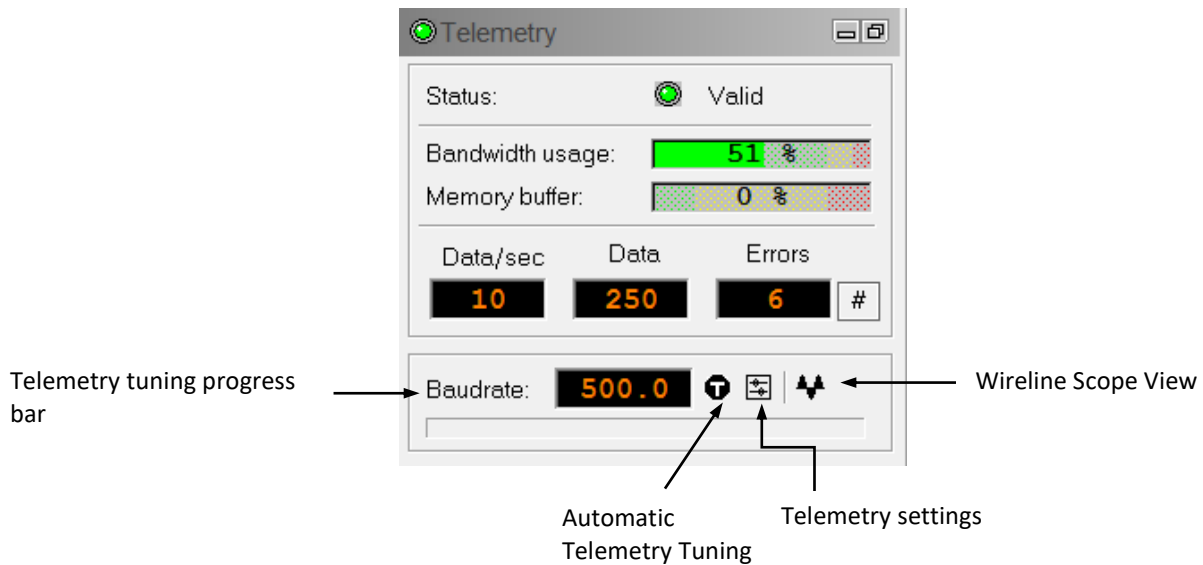

Baud rate:

Indicates the default baud rate or optimal baud rate in kbps found by the system for the selected winch/telemetry scheme

Automatic Telemetry Tuning:

The Tune button  resets the telemetry tuning automatically. This process defines:

- the optimum baud rate for the winch configuration selected
- a transfer function and a filter to re-construct at the surface the shape of the pulse trains distorted by the wireline.⁵ Refer to the **Equalizer** paragraph for more details.

The Automatic Tuning is very useful on wireline over 1000m length to optimize the telemetry performance and logging speed.

A **progress bar** at the bottom of the telemetry window shows the progression of the telemetry tuning. At the end of the process the baud rate display is refreshed with the optimal baud rate value.

⁵ The transfer function and filter concept are only valid for tools implementing the latest generation of ALT MODEM telemetry board (i.e. QL40-ABI2G, ABI-GR-2G, QL40-OBI2G, OBI-GR-2G, QL43-ABI2G,...)

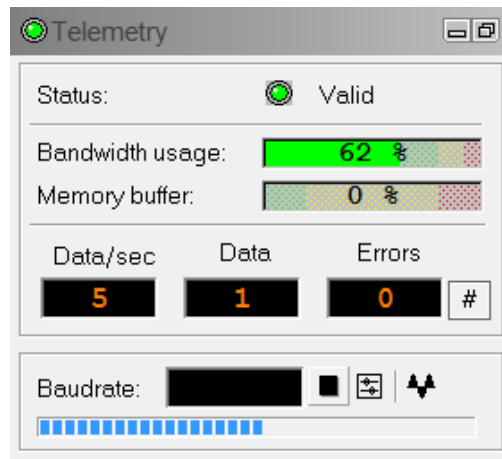

Scope:

Pressing the scope button  on the **Telemetry Panel** brings up a **Wireline Scope** view (Figure x), which displays the pulse strings transmitted through the wireline and received by the system at the surface.

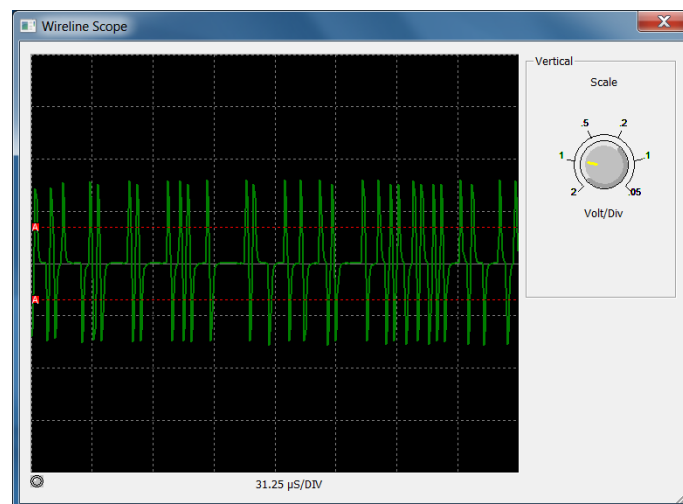

The two red-dashed horizontal lines help to visualize the position of the discriminator levels set for detecting the pulses at the surface. Discriminator levels can be tuned in the **Telemetry Settings** dialog – refer to section 3.6.1 for more information.

The Scale knob can be adjusted to show more or less vertical details. This view has no effect on the communications and is a visual aid only.

Telemetry Settings:

The Telemetry Settings button  opens a **Telemetry** control panel summarizing the telemetry status and configuration.

If the system cannot establish a stable communication with the tool, the **Settings and Equalizer tabs** allow the user to modify the telemetry settings and to apply a telemetry filter (Equalizer option)

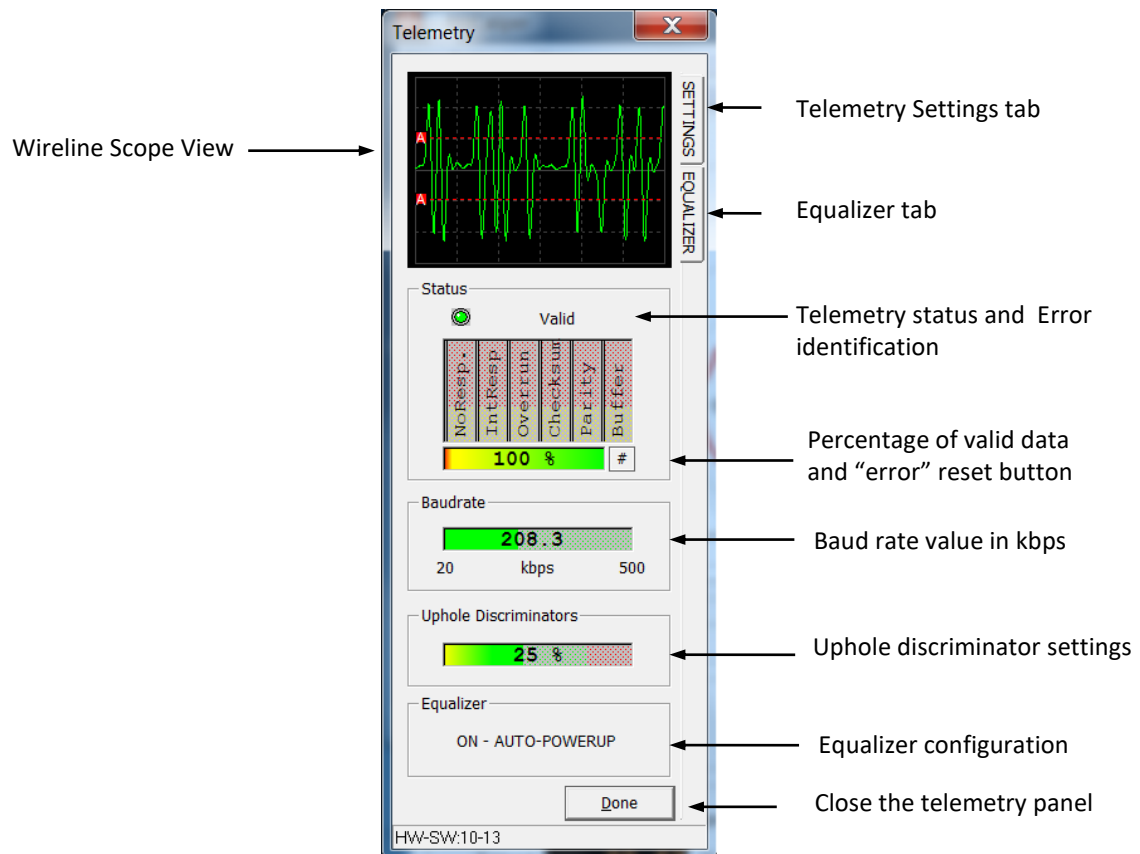

Adjusting the Telemetry Settings:

By default the telemetry settings are set to Automatic mode and should stay in this configuration. When more advanced tuning is required (i.e. long wirelines having a limited bandwidth) the manual mode can be activated.

In Automatic mode the uphole discriminators are set automatically to detect the pulse strings.

The position of the discriminator levels are visible on the Scope and Analysis views and are represented by two red dashed lines – one for the positive pulses and the other for the negative pulses.

The “A” letter on the red square means that the discriminators are set in automatic mode. The **Scale knob** controls the scale for the Analysis and Scope displays.

Position of the discriminator lines should be set as illustrated below.

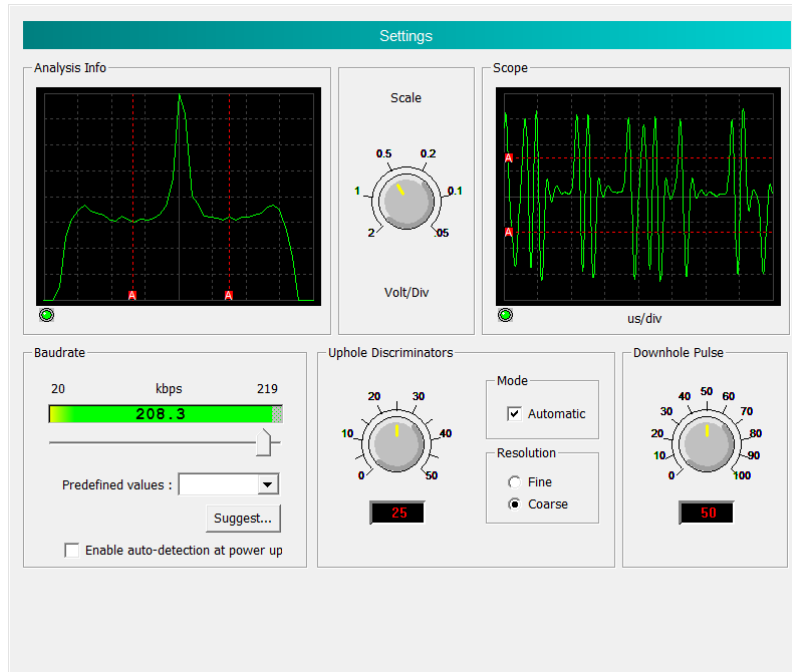

When the automatic mode is unchecked user has the option to adjust manually the uphole discriminators using either the discriminator knob or by moving interactively the red dashed lines in the Analysis and Scope displays. The red triangles located at the extremities of the red dashed lines refer to manual mode. For fine tuning of the discriminators the **Fine resolution** can be chosen.

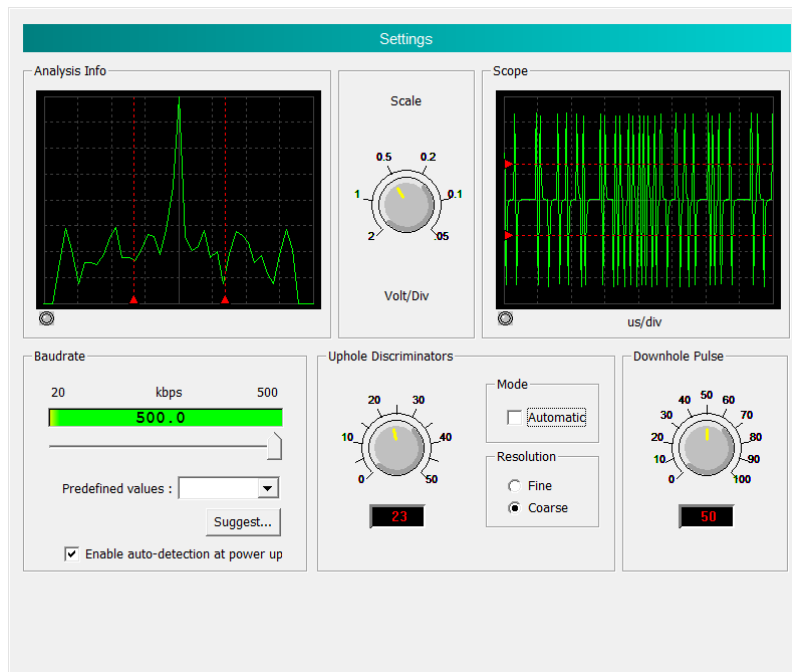

The **Downhole Pulse knob** controls the width of the pulse commands sent to the tool. It is set on 50 as a default value. This value is the preferred one and is suitable for a wide range of wirelines. For long wireline increasing the pulse width could help to stabilize the communication. The reverse for short wireline.

The **Baudrate** is generally set to the maximum value for which the communication status stays valid in order to optimize the logging speed for the wireline configuration. The baudrate can be adjusted by moving the cursor below the baudrate bar meter or by selecting a predefined baudrate value from the select box.

When clicking the **Suggest** button the system is searching for the optimum baudrate value and keeps this value for the data transmission.

The **Enable auto-detection at power-up** configures the system such a way that the baudrate is reset to its optimum value each time a tool is powered up.

Applying the Equalizer

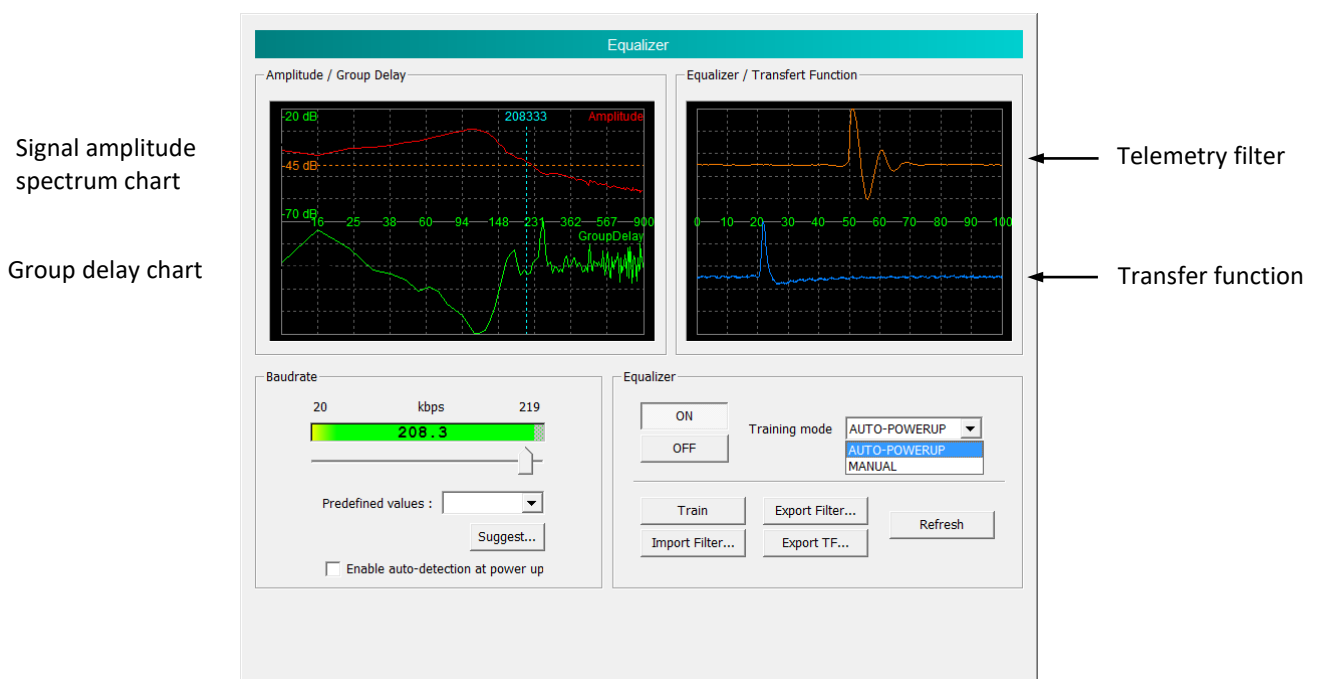

The **Equalizer** dialog provides some advanced telemetry settings described hereafter.

- The **Train** button computes the transfer function of a wireline - refer to the blue signal. When clicking on Train the tool sends a pilot pulse frame to the surface. The received signal at the surface is compared with the original pilot pulse frame to measure the distortion of the signal through the wireline. The result of this process is the definition of a transfer function specific to the wireline used.

A filter is then derived from the transfer function - refer to the orange signal. The filter will be applied on the telemetry signal to counteract the distortion of the pulse strings through the wireline.

Applying the filter will thus improve the telemetry performance of the system and logging speed on wirelines with unfavorable band width.

- The **Equalizer ON/OFF** buttons enables or disables the filter. The activation of the equalizer can be configured to **MANUAL** mode or to **AUTO-POWERUP**.

The AUTO-POWERUP feature applies the telemetry filter upon tool power-up.

- The **Export TF** option exports the **Transfer Function** defined by the wireline training process in a ASCII file format
- The **Export Filter** option exports the **Filter** derived from the transfer function in a ASCII format
- The **Import Filter** option loads a saved filter configuration
- The **refresh** button is refreshing the Equalizer/transfer function display

The **Amplitude/Group Delay** charts are mostly used by ALT developers for telemetry signal and performance analysis.

The Equalizer dialog repeats the **Baudrate** settings already discussed in the previous paragraph "Adjusting telemetry settings".

9.2 Parts list

Detailed part numbers and descriptions are available for tool delivery and spare part kits. Please contact support@alt.lu for further details.

9.3 Technical drawings

The following technical drawings are available on request:

- 19" Rack connection diagram.
- Wiring Diagram.

Index

AbiCaliper, 34
AbiSurfaceImg, 32
AbiThicknessImg, 33
Acoustic head, 40
Acoustic head operation, 6
ALT Logger, 15
Amplitude, 30
Azimuth, 30
Azimuth accuracy, 4
Azimuthal Resolution, 27
Baudrate, 15
bottom sub, 9
Calculation of Casing Thickness, 51
Caliper Browser Window, 34
Cleaning the acoustic head bottom section, 41
Computation of Caliper Data, 50
Configuring Tool Parameters, 17
Diameter, 3
Dimensions, 2
discriminators, 16
Downhole Pulse width, 16
Estimation of Fluid Velocity, 49
firmware, 42
Functionality test, 36
General Information, 1
Gravity, 30
head, 6
impedance, 5
Inclination accuracy, 4
Length, 3
Magn.Field, 30
Maintenance, 37
MATRIX, 16
Max. Temp, 3
Max.Pressure, 3
MChNum Browser Window, 31
Measurement Principle, 5
mid sub, 9
Mirror rotation, 36
Motor Period, 30
Motor Status, 30
MotSpeed, 30
Mroll, 30
Notes on Data Processing, 49
Operating Procedure, 13
Overview, 1
Parts list, 58
Performance Check & Calibration, 36

Pressure Housing, 42
QL, 9
QL tool, 9
Quick Start, 14
Recorded Parameters and Browsers, 30
Reflection coefficient, 5
Roll, 30
Rolling test, 36
Score, 30
stack assembly, 9
Surface Image Browser Window, 32
T APS, 30
T CPU, 30
Technical drawings, 58
Technical Specification, 3
Telemetry, 15, 16
Thickness Image Browser Window, 33
ThicknessTTime, 30
Tilt, 30
Tool Communication with ALT Logger, 15
Tool Communication with MATRIX, 16
Tool Head Adapter, 38
TravelTime, 30
Trouble Shooting, 47
Upgrading ABI40 firmware, 42
VT CPU, 30
Weight, 3
WndAmpl, 30
WndTime, 30