

User Guide

QL40 HM 453 & QL40 HM 453E

Magnetic Susceptibility



Advanced Logic Technology sa

ZAE Solupla
Route de Niederpallen 30H
L-8506 Redange-sur-Attert
Luxembourg

Phone : +352 28 56 15-1
Fax : +352 28 56 15 40
Email : support@alt.lu
Web : www.alt.lu

Mount Sopris Instruments

4975 E. 41st Avenue
Denver, CO 80216
USA

Phone : +303 279 3211
Email: sales@mountsopris.com
Web : www.mountsopris.com

Table of Contents

1	General Information	1
1.1	Dimensions	2
	Figure 1-1 Tool general arrangement	2
1.2	QL40-HM-453 Technical Specifications	3
2	Measurement Principle	4
2.1	Magnetic Susceptibility	4
	Figure 2-1 Diagram of Mag. Susc. and Induction tools with corresponding ranges of measurement.....	4
3	QL40 HM 453 Assembly and Set up.....	5
3.1	QL40 Tool Stack Assembly	5
4	Operating Procedure.....	8
4.1	Quick Start	8
4.2	Tool Communication with OPAL/SCOUT (ALT MODEM)	9
4.3	Tool Communication with MATRIX	10
4.4	Recorded Parameters, Processors and Browsers.....	11
4.4.1	Recorded parameters.....	11
4.4.2	MChNum Browser	12
4.4.3	MChCurve Browser.....	13
4.5	Performance Check and Calibration	14
4.5.1	Calibration Steps	15
5	Maintenance	18
5.1	General maintenance	18
5.2	Locking Ring Assembly Maintenance	18
6	Troubleshooting.....	20
7	Appendix	21
7.1	Replacement Parts.....	21
7.2	Other Parts	21
8	Probe Tops - Standard Configurations.....	22
8.1	QL40-GO4 Four Conductor Tool Top	22
8.2	QL40-MS1 and QL40-GO1 Single Conductor Tool Tops	23

1 General Information

The QL40-HM-453 Magnetic Susceptibility bottom sub is a versatile wireline tool that can be used in a wide variety of logging applications.

It is designed for measurement of magnetic susceptibility of rocks in both liquid filled and dry boreholes. The QL40-HM-453 is capable of logging inside PVC or other non-metallic casings. It is characterized by high stability and exceptionally wide dynamic range. The magnetic susceptibility measurement uses a 2 kHz frequency.

The HM-453 probe uses a 2-coil array with 25 cm spacing between the transmitter coil and receiver coil for the magnetic susceptibility measurement.

This probe is also available in two other models: a QL40-HM-453E extended range probe, and a QL40-HMM-453 dual range probe (see **Figure 2-1**). All probes operate the same way, but the ranges and physical dimensions are different.

A combination QL40-HMI Magnetic Susceptibility and Induction probe is also available, but tool details and specifications are found in a separate manual.

QL40 Stackable Logging Tool Overview

QL stands for Quick Link and describes the latest line of stackable logging tools. This development is a joint venture of Mount Sopris Instruments (MSI) and Advanced Logic Technology (ALT). Innovative connections between tool elements (subs) allow users to build their own tool strings in the field. The Tool Stack Factory – a sophisticated extension of the acquisition software – provides a convenient way to configure tool strings for operation. For more information about the Tool Stack Factory, see the LoggerSuite Manual.

Each sub has a Telemetry and Power supply element, TelePSU, allowing stand-alone operation. A GenCPU card in each sub handles Analog to Digital conversion and/or counting of the measurement signal and formatting data for transmission up hole.

The QL40-HM-453 bottom sub can be operated as a stand-alone probe or can be stacked below inline subs. The stack is completed by adding a Tool Top sub. Varied tool top subs are available. Top subs include an MSI single conductor, GO4 conductor, GOI Single conductor and GO7 conductor. Consult the factory for additional options.

The number 40 indicates a nominal probe OD of 40mm and tool joint connection diameter, but some probes in the 40mm probe line can have larger diameters. This probe, the QL40-HM-453 is a 45mm diameter probe with the 40mm QL tool connection.

For a more detailed discussion of QL subs and their connections, please refer to **Chapter 3**.

1.1 Dimensions

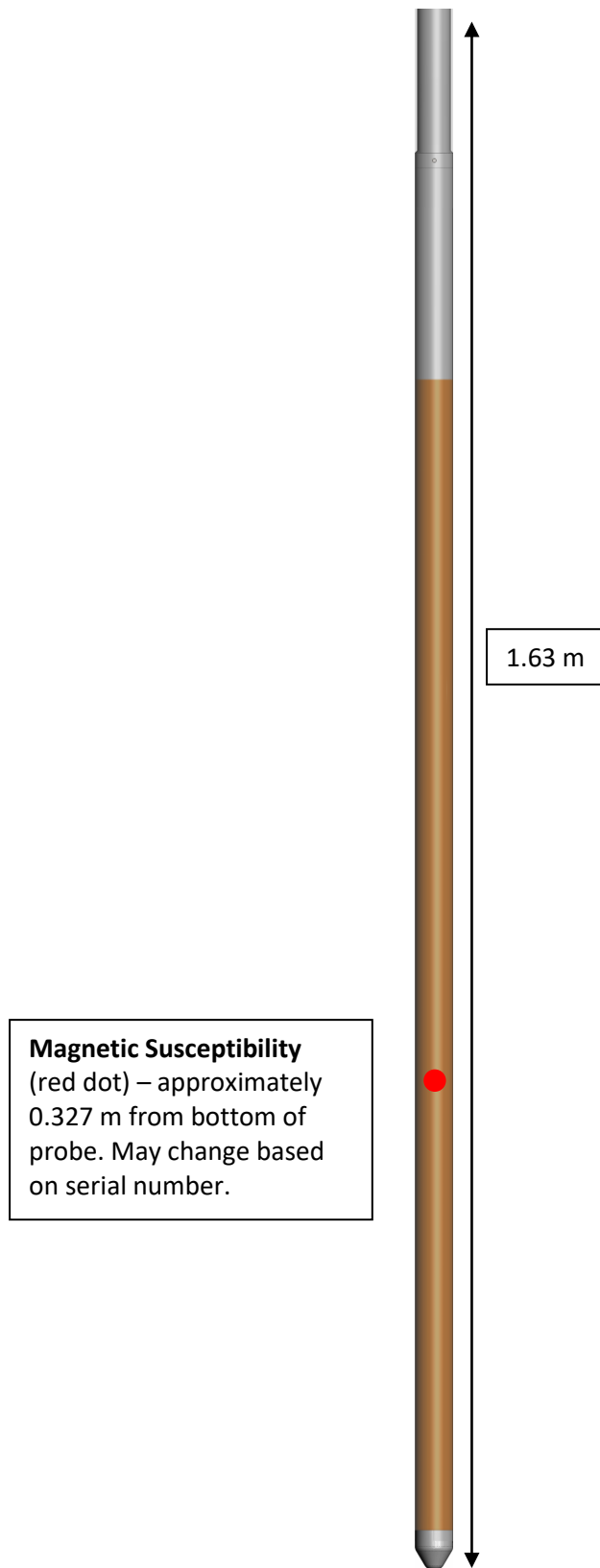

Figure 1-1 Tool general arrangement

1.2 QL40-HM-453 Technical Specifications

Tool:

Diameter:	45 mm (1.77 in.)
Length:	1.632 m (64.25 in.) *May vary by tool type
Weight:	5.7 kg (12.5 lbs)
Max. Temperature:	70 °C (158 °F)
Max. Pressure:	200 bar (2900 PSI)

Cable:

Cable type:	Mono, Coaxial, 4 or 7 conductor
Digital data transmission:	Up to 500 Kbits per second depending on wireline
Compatibility:	ScoutPro – Scout – Matrix – BBox – OPAL

Measurement:

Sensor:	HM-453 and HM-453E, Two coil system HMM-453, Four coil system
Intercoil Spacing:	HM-453, 25 cm HM-453E, 30 cm HMM-453, 25 cm and 30 cm
Operating Frequency:	1935 Hz
Estimated Range:	HM-453, 10^{-5} – 0.5 SI HM-453E, 10^{-4} – 2 SI HMM-453, 10^{-5} – 0.5 SI and 10^{-4} – 2 SI
Range (Real):	See W&R Technical Data Manual
Accuracy:	< 3%
Zero Temperature Stability:	< $0.5 * 10^{-5}$ SI/°C
Communication (Negative Pulse):	0 – 35,000 cps

Power:

DC voltage at probe top:	Min 80 VDC Max 160 VDC Nominal 120 VDC
Current:	Nominal 25mA

2 Measurement Principle

2.1 Magnetic Susceptibility

The magnetic susceptibility (MS) of a volume of rock is a function of the amount of magnetic minerals, mainly magnetite and pyrrhotite, contained within the rock. MS measurements can provide a rapid estimate of the ferromagnetism of the rock. These measurements can be interpreted to reflect lithological changes, degree of homogeneity, and/or the presence of alteration zones in the rock mass. During the process of hydrothermal alteration, primary magnetic minerals (e.g. magnetite) may be altered or oxidized to weakly- or non-magnetic minerals (e.g. hematite). Anomalously low susceptibilities within an otherwise homogeneous high susceptibility (ferromagnetic) rock unit may indicate altered zones.

Basic flows and diabase dikes containing higher concentrations of magnetic minerals can be easily outlined with magnetic susceptibility measurements when they occur within a sedimentary sequence that normally contains little or no magnetic minerals (from NRCAN.GS.CA website).

The QL40-HM-453 probe uses a pair of coils spaced 25 cm apart, and it generates a 1.9345 kHz square wave which is transmitted into the surrounding rock material. The signal measured by the receiver coil is proportional to the magnetic susceptibility of the host rock.

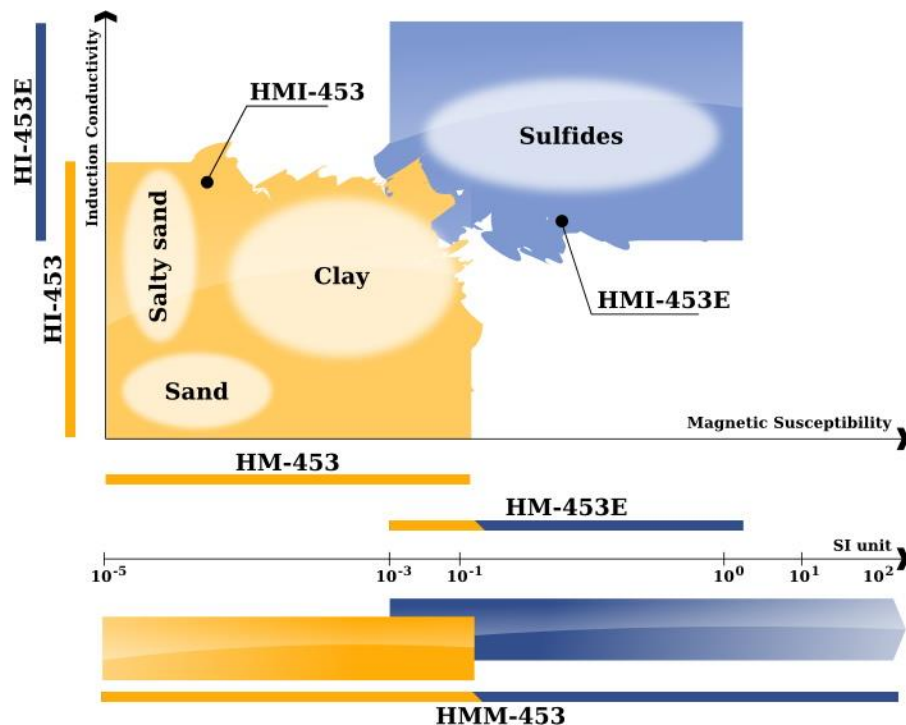

Figure 2-1 Diagram of Mag. Susc. and Induction tools with corresponding ranges of measurement.

3 QL40 HM 453 Assembly and Set up

QL stands for **Quick Link** and describes an innovative connection between logging tools (subs) allowing for custom built tool stacks. QL40 describes a specific family of logging tools. Each sub is equipped with its own Telemetry board, Power supply element and A/D converter allowing an operation as stand-alone tool or as a stack in combination with other subs of the QL product family.

The QL40 probe line deals with two types of subs - Bottom Subs and Mid/Inline Subs.

Bottom Sub

A bottom sub is a tool that must have one or more sensors located at the bottom. It can be operated in combination with other QL subs connected to the top but it is not possible to connect another sub below. When used in stand-alone mode the bottom sub only needs a QL40 tool top adaptor, which fits the cable head.

Mid/Inline Sub

A mid/inline sub is a tool that can be integrated anywhere within a stack of tools. When used at the bottom of a tool string a QL40 bottom plug must be used to terminate the string. If the mid/inline sub is used as a stand-alone tool it needs a QL40 bottom plug at the lower end and a QL40 tool top adaptor at the top.

3.1 QL40 Tool Stack Assembly

A QL40 tool stack may be terminated by either a QL40 bottom sub or a QL40 bottom plug. The QL40-HM-453 is a bottom sub, so it does not require a QL40 bottom plug.

At the top of the stack a QL40 tool top is required to connect the tool string to the cable head. Several tool tops are already available; special ones can be made on request. Common tool tops include the QL40-GO4 for Gearhart-Owen 4 conductor cable heads, the QL40-MS1 for single conductor Mount Sopris cable heads, and the QL40-GO1 for Gearhart-Owen single conductor cable heads.

To assemble and disassemble the subs or top, the C-spanner delivered with the tool must be used (**Figure 3-1**). It is recommended that before each assembly the integrity of the O-rings (AS216 Viton shore 75) is verified. Prime the O-rings with a small amount of the silicon grease that was supplied with the subs.

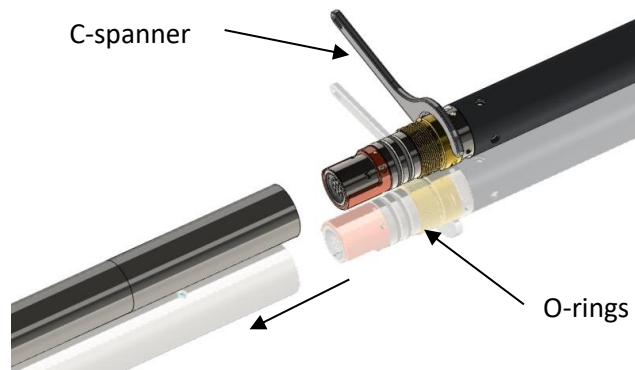

Figure 3-1 C-spanner and O-rings of QL connection

The following example of a QL40-ABI-2G, QL40-GR, and QL40-GO4 (**Figure 3-2**) describes how to replace the QL40-ABI-2G with a QL40-Plug to run the QL40-GR sub stand-alone.

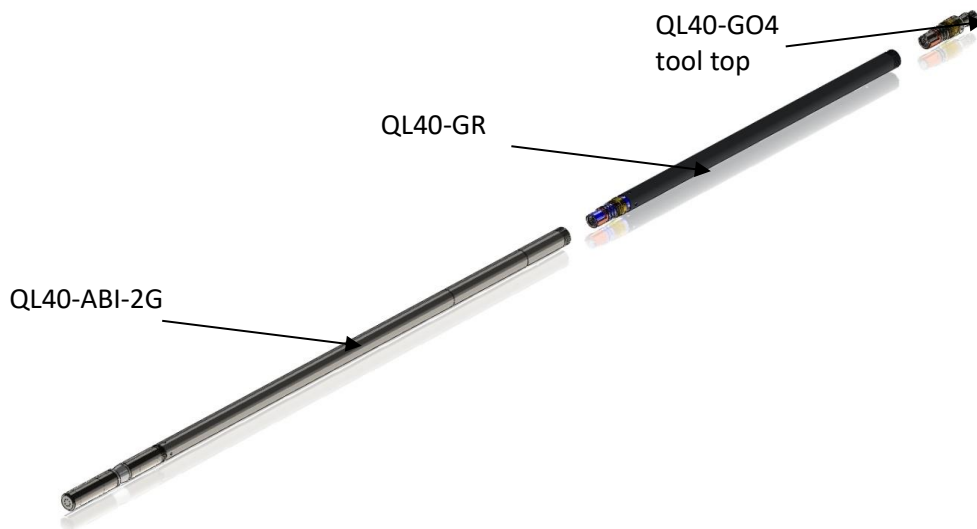

Figure 3-2 Tool stack example

To remove the QL40-ABI-2G televiewer sub from the QL40-GR gamma sub, attach the C-spanner to the thread ring as shown in **Figure 3-3**, unscrew the threaded ring, (counter-clockwise about the tool axis when looking towards the bottom of the tool), and remove the QL40-ABI-2G bottom sub.

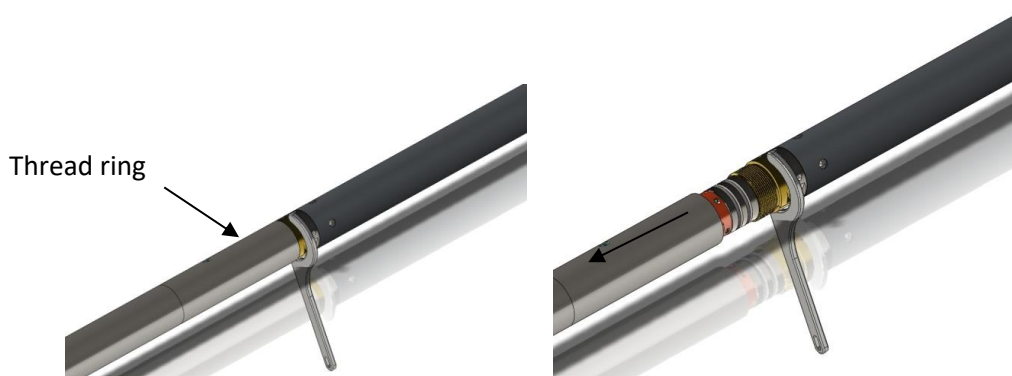

Figure 3-3 Unscrewing the thread ring and removing the bottom sub

After checking the O-ring integrity, align and slip the QL40-Plug, also known as the QL40-BOT, over the exposed QL connector (**Figure 3-4**). Attach the C-spanner wrench and screw the threaded ring until the plug draws up tight to the ring. **Do not** overtighten the threaded ring.



Figure 3-4 Attaching the QL40-Plug

The QL40-GR can now be run stand-alone (**Figure 3-5**).



Figure 3-5 QL40-GR with top and bottom

4 Operating Procedure

Note: Parts of the topics discussed in these sections below assume that the user is familiar with the **LoggerSuite** acquisition software. LoggerSuite is the collection of Logger, LoggerSettings and TFD2LAS software. Refer to the corresponding operator manuals for more details. Information about assembly and configuration of tool stacks can be found in the same manuals.

4.1 Quick Start

1. Connect tool to cable head and lower into the borehole. Start Logger acquisition software.

2. Select the relevant QL40-HM-453 tool stack from the drop down list (**Figure 4-1**) in the Tool panel (if your tool stack is not listed, check that your tool configuration file is stored in the designated folder on your computer or create a new file using the Tool Stack Factory).

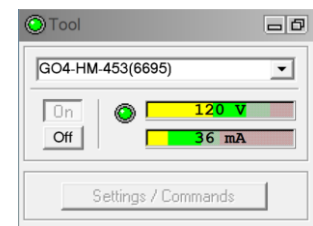



Figure 4-1 Tool panel

3. In the **Tool** panel switch on the tool (click **On** button). Verify that the voltage indicator shows a valid green level (shown as 120 V in **Figure 4-1**). The current indicator should also be green and greater than 10 mA (shown as 36 mA in **Figure 4-1**). The system goes through a short initialization sequence which sets the default parameters and communication settings held in the tool configuration file. The configuration returned by the tool is also checked during this procedure (Setup tool communication as explained in **Chapters 4.2 and 4.3**).

4. Click the extend icon  in the **Depth** panel and press **Zero Tool** (**Figure 4-2**).

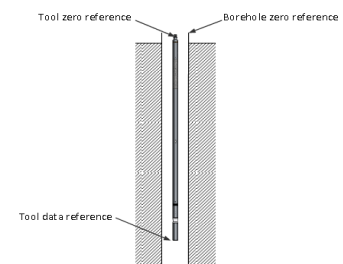





Figure 4-2 Correct tool positioning when zeroing depth

5. The tool should be allowed to warm-up in the borehole fluid for at least 15 minutes before calibrating, so it is at the borehole temperature. This will provide the most accurate calibrations.
6. Remove the tool from the borehole. Calibrate the QL40-HM-453 tool by following the steps outlined in **Chapter 4.5**. Place the tool into the borehole.
7. In the **Acquisition** panel (**Figure 4-3**) select the sampling mode (**Depth Down** or **Depth Up** depending on logging direction). Click on **Settings** and specify the corresponding sampling rate. Switch on the sampling (click the **ON** button). Note: The sampling button needs to be set to **OFF** before changing modes. **Time** mode is used for calibration and verifying tool operation at the surface.

8. If desired, complete a **Header**  in the **Acquisition** panel (**Figure 4-3**). Press the **Record**  button, specify a file name, and start the logging.
9. During logging observe the controls in the **Telemetry** panel (**Figure 4-4**):
 - Status must be Valid (green light);
 - Bandwidth usage in green range, usually below 80%;
 - Memory buffer should be 0%;
 - Number of **Errors** negligible as **Data** increases.
10. To end the logging procedure, press the **Stop**  button in the **Acquisition** panel and turn off the sampling (click **OFF** button).
11. In the **Tool** panel, power off the tool (click **OFF** button).

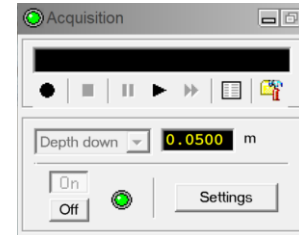

Figure 4-3 Acquisition panel

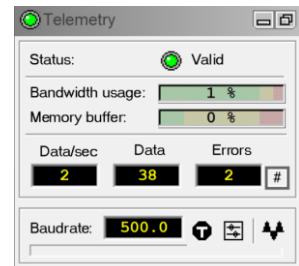
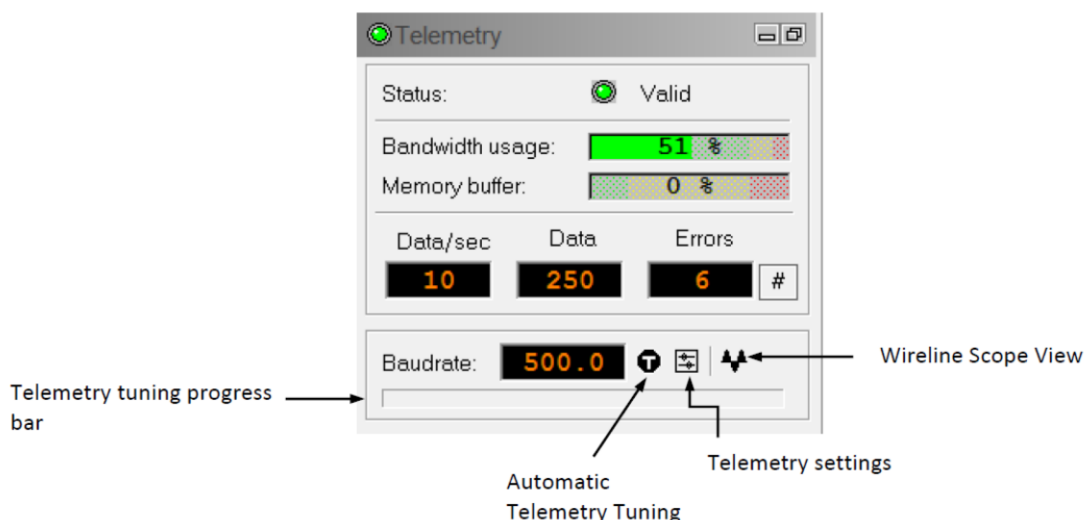

Figure 4-4 Scout Telemetry panel

4.2 Tool Communication with OPAL/SCOUT (ALT MODEM)

The telemetry provided through the **OPAL-SCOUT** systems implementing the **ALT MODEM** controls and configures **AUTOMATICALLY** the telemetry settings for any wireline. In case communication status is not valid the user has different options to adjust manually the telemetry settings from the telemetry panel of the dashboard:



Baud rate:

Indicates the default baud rate or optimal baud rate in kbps found by the system for the selected winch/telemetry scheme.

This tool does not require baud rates higher than 100.0 kbps. Manual adjustment might be necessary to lower the baud rate using the  **Telemetry Settings** button and then the **Settings** tab.

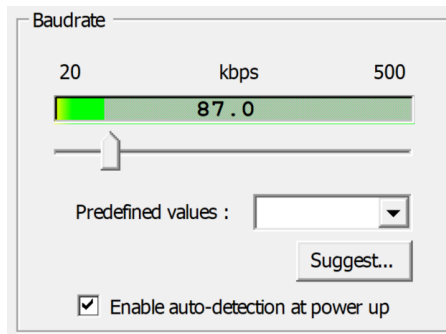



Figure 4-2 Scout baud rate settings

Automatic Telemetry Tuning:

The Tune button  resets the telemetry tuning automatically. This process defines:

- The optimum baud rate for the winch configuration selected
- A transfer function and a filter to re-construct at the surface the shape of the pulse trains distorted by the wireline.



A **progress bar** at the bottom of the telemetry window shows the progression of the telemetry tuning. At the end of the process the baud rate display is refreshed with the optimal baud rate value.

Refer to **LoggerSuite manual** for more information on the advanced telemetry settings.

4.3 Tool Communication with MATRIX

The tool telemetry can be configured through the **Telemetry** panel of the Matrix dashboard. By clicking on , the operator has access to the **Configure ALT Telemetry** dialog box (**Figure 4-5**) providing various controls to adjust the telemetry settings and monitor its current status.

The **Analysis View** displays the current discriminator levels (vertical yellow lines) and a histogram of the up-hole data signal. The scales of the **Analysis View** can be adjusted using the **Vertical Scale** and **Horizontal Scale** knobs and the **linear / logarithmic** scale buttons.

The status of the configuration should be flagged as  **Valid**. In any other case (e.g.  Int. resp.) the telemetry should be adjusted (we assume a pulse signal is displayed in the analysis view). Click on the **<<Advanced** button to display additional controls to tune the telemetry.

The Automatic settings option is the preferred mode and should allow the telemetry to be configured for a wide range of wirelines without operator input. For wirelines with a more limited bandwidth, the operator might need to turn off the automatic mode and adjust the telemetry settings manually.

In general, the gain setting should not be left in the automatic mode once a valid setting has been determined. Uncheck the box to disable automatic gain.

For each wireline configuration, the discriminators (vertical yellow lines) **Positive Discr** and **Negative Discr** can be adjusted to obtain a valid communication status (see *Figure 4-6* for an example of a suitable discriminator position). There is also the option to alter the **Baudrate** to optimize the logging speed. The input **Gain** can be increased (long wirelines) or decreased (short wirelines) to set up the discriminator levels correctly.

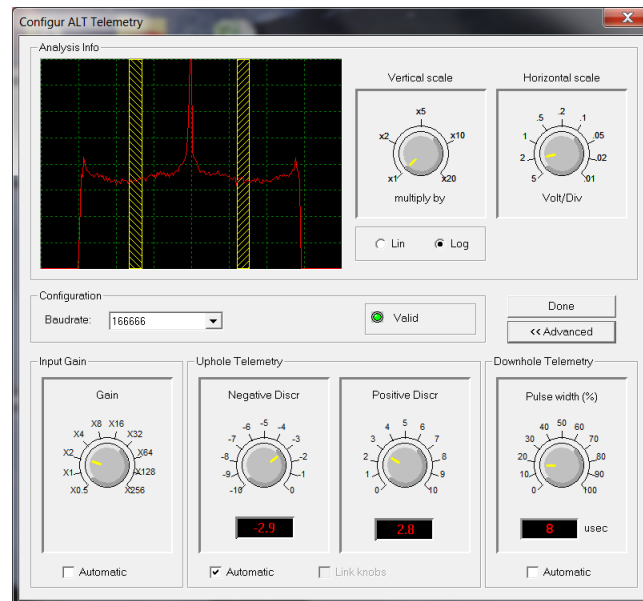

Figure 4-6 Matrix telemetry settings

Once the telemetry is correctly set, store the new settings as default. The tool should go through the initialization sequence in **Valid** status the next time the power is turned on.

4.4 Recorded Parameters, Processors and Browsers

4.4.1 Recorded parameters

The following channels are recorded by the QL40-HM-453 tool:

Time	Sampling Time [seconds]
TCPU	Temperature (recorded on CPU board) [degrees C]
COUNT	Magnetic Susceptibility Counts
MagSus	Magnetic Susceptibility [10e-3 SI Units]
Speed	Logging Speed in [meters/minute or feet/minute]
ToolPowerVoltage	DC Voltage supplied to the probe [Volts]
ToolPowerCurrent	Electrical Current supplied to the probe [mAmps]
Tension	Wireline Tension [daN]

Table 1 QL40-HM-453 recorded channels

4.4.2 MChNum Browser

Figure 4-7 shows a typical example of the numerical value displayed in the MChNum browser window during operation.

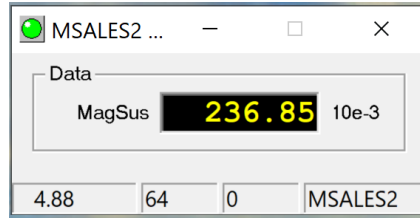



Figure 4-7 MChNum browser window

The other parameters listed in **Table 1** can be displayed in real time if required. To do this, click on the MChNum browser green LED  and click on **Display options...** from the menu.

Select in the **Numerical Displays** tab and add the additional channels to display using the left and right arrows (**Figure 4-8**).

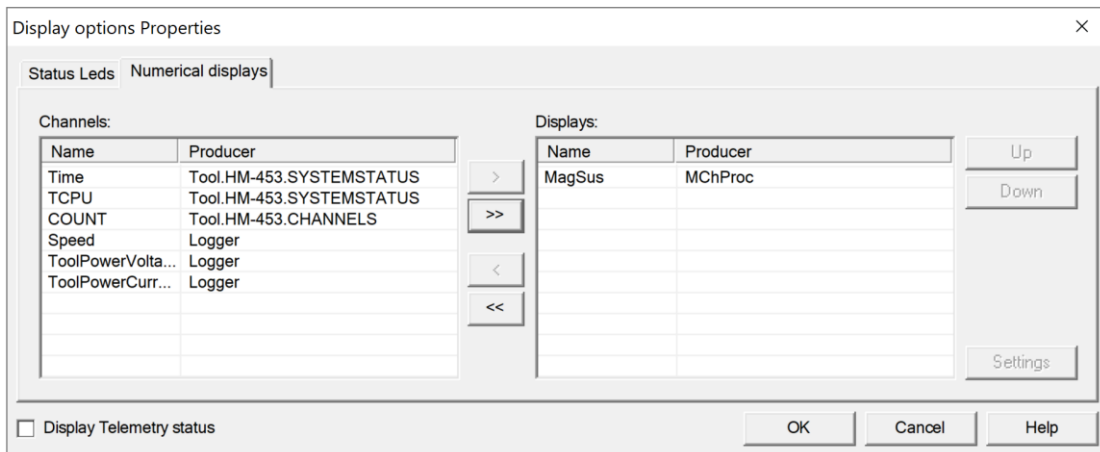

Figure 4-8 Display Options Properties window

It is possible to change the number of decimal digits displayed for a channel. Select the channel and click on **Settings** to configure the number of digits after the period (**Figure 4-9**).

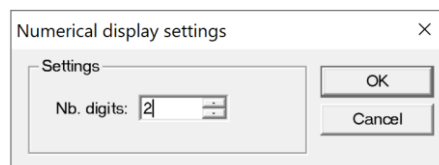

Figure 4-9 Numerical Display Settings window

4.4.3 MChCurve Browser

The MChCurve browser (**Figure 4-10**) displays the recorded parameters by means of curves in real time.

The user can modify the curve presentation by double clicking on the log title (colors, column position, scale, filter, grids, etc.).

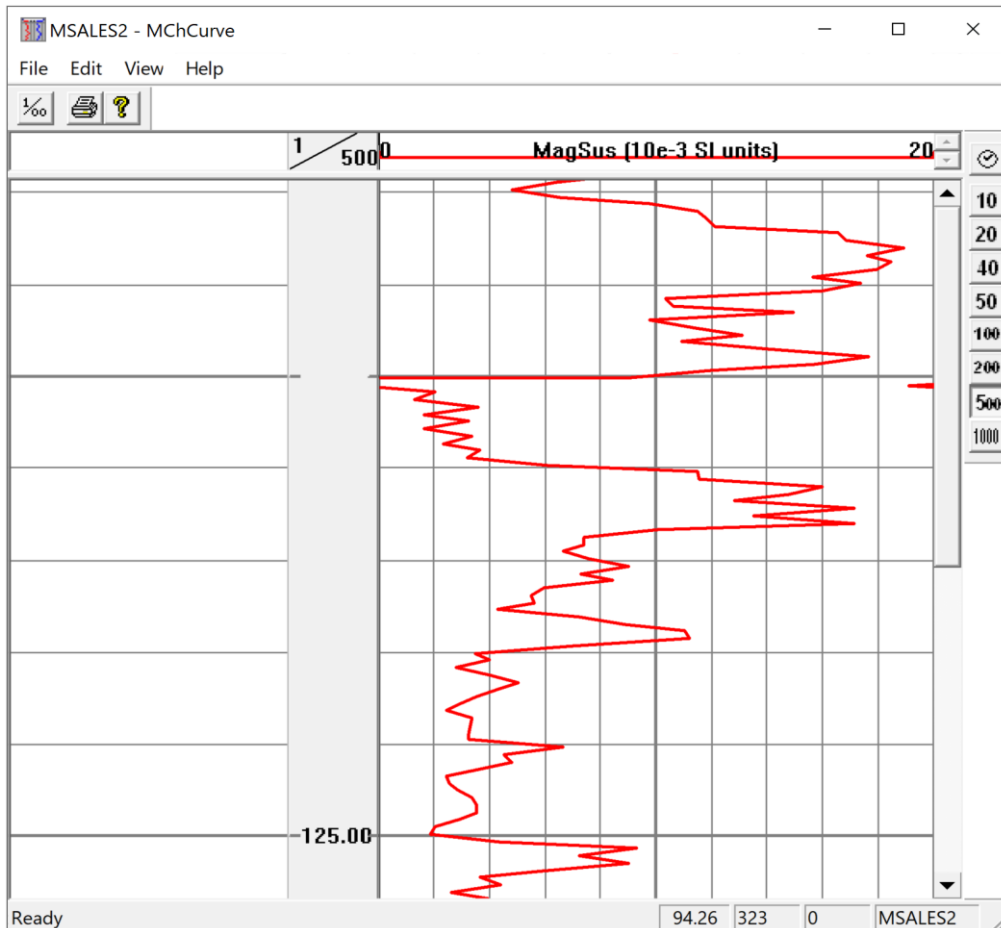

Figure 4-10 QL40-HM-453 MChCurve browser

The other parameters listed in **Table 1** can be displayed in real time if required. To do this, select **Edit** and click on **Show Logs...** from the menu (**Figure 4-11**). All logs with a check mark will be displayed.



Figure 4-13 QL40-HM-453 calibration mount and pucks

The QL40-HM-453 Magnetic Susceptibility probe should be calibrated in the field before every use.

4.5.1 Calibration Steps

1. Connect the QL40-HM-453 probe to the cable head and turn on the tool as outlined in **Section 4.1 Quickstart**. Lower the tool into the borehole fluid and allow it to warm up for at least 15 minutes to allow the tool to equilibrate, so that the measurements do not drift. Remove the probe from the borehole.
2. In the **Acquisition** panel, turn **Time** sampling **On**. Left click on the Green LED  in the upper left corner of the **MChNum** window and click on **Calibration Settings...** (**Figure 4-14**).

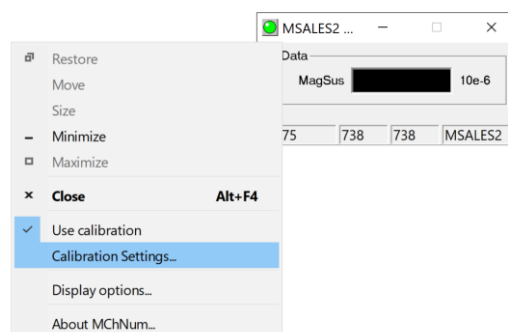

Figure 4-14 Open Calibration Settings window from MChNum

3. The probe should be suspended in air, approximately 1.5 m (5 feet) above the ground and at least 3.3 m (10 feet) from any metallic or conductive objects. If the operator is manually holding the probe above the ground surface during the calibration, be sure to remove all metal from pockets. This represents a zero magnetic susceptibility reference.

- Enter **0** as the **Reference** for the **First Point** in the **Calibration Settings** window (**Figure 4-15**). Click **Sample....** Wait until the bar loads. After loading, a new value will appear in the **Value** for the **First Point**.

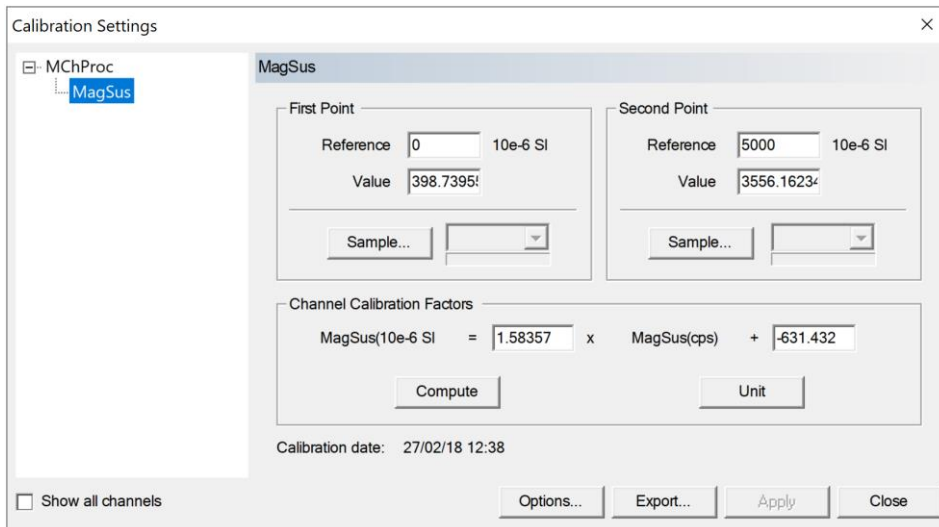

Figure 4-15 Calibration Settings window

- Screw the high calibration puck into the calibration plate.
- Slide the calibration plate onto the probe until the calibrator is centered on the red dot (**Figure 4-16**).



Figure 4-16 QL40-HM-453 with 5×10^{-3} SI calibration puck in place.

- Enter **5000** (or the value stamped on the puck) as the **Reference** for the **Second Point** in the Calibration Settings window (**Figure 4-15**). Click **Sample....** Wait until the bar loads. After loading, a new value will appear in the **Value** for the **Second Point**.
- Press **Compute** and then **Apply** to store the new calibrations.
- Close out of the **Calibration Settings** window. On the **Browsers & processors** panel, click **Close All** and then click **Start All**. This should close all windows on the screen and then open them again, to reinitialize the other Browsers/Processors (**Figure 4-17**).

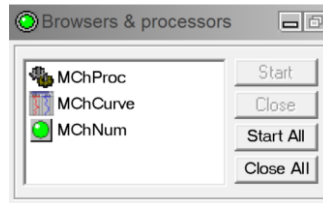

Figure 4-17 Browsers & processors panel

10. To test the calibration accuracy, use the QL40-HM-453 with both pucks (**Figure 4-18**) or with the smaller 2.4×10^{-3} SI puck (**Figure 4-19**). When using both pucks together, you will need to add the reference numbers (e.g. 5.0×10^{-3} SI + 2.4×10^{-3} SI = 7.4×10^{-3} SI). The **Mag Sus** measurement displayed in the **MChNum** window should display approximately the same amount as the puck or pucks being tested.



Figure 4-18 QL40-HM-453 with 2.4×10^{-3} SI and 5×10^{-3} SI calibration pucks in place.



Figure 4-19 QL40-HM-453 with 2.4×10^{-3} SI calibration puck in place.

5 Maintenance

Warning: Removing the electronic chassis from pressure housing without prior consultation with ALT/Mount Sopris will void the tool warranty.

5.1 General maintenance

The QL40 series tools require periodic maintenance. Make sure the threads on the brass nut on the sub bottom are free of sand, mud, or other dirt. A thin layer of anti-seize grease is recommended.

When disassembling the probe string, dry the joint as it is separated to prevent fluid from entering the sub top and getting into the electrical connector inside. After replacing top, it is good to wash the probe off after each use.

Never take the probe apart. This probe is very difficult to disassemble and requires special steps to gain access to the inside of the probe without damaging the electronics. If you have read this after attempting to disassemble the probe, chances are the probe has experienced damage and will need to be sent to the factory to be repaired.

Inspect O-rings occasionally and keep the threads on both ends of the probe clean, to minimize problems in the future. Do not store this probe near a strong magnet, as over time, this could affect the accuracy of the sensors and the resulting measurement.

Remember that the **housing is constructed of fiberglass and is somewhat fragile**. Use care when placing the tool in the borehole and when traveling down into the borehole. Also, store the tool in a secure place, preferably in a shock resistant container. During transport, logging tools typically endure more shock than when in the borehole.

5.2 Locking Ring Assembly Maintenance

Tools required:

1.5 mm Allen wrench
2 each, 40-42 mm spanner wrench
Paper towels or clean rags

Replacement Parts:

ALT26005, Large Threaded Ring, Quantity 2
28-174-995, M2x8 SHCS Screws, Quantity 2

Disassembly:

Unscrew and remove the two M2x8 socket head cap screws (SHCS) and separate the two halves.

Four guide pins align the two ring halves and tend to hold them together after the screws are removed.

To pry the halves apart you can use a pair of spanner wrenches inserted into the pin holes on opposite sides of the ring mating surfaces to pull them apart slightly. *Do this carefully to prevent bending the guide pins.*



Figure 5-1 Disassembly of the treaded ring

Place something small in the opening and move the spanners to the other side and pry it open slightly. This should be enough to release the two rings as below.

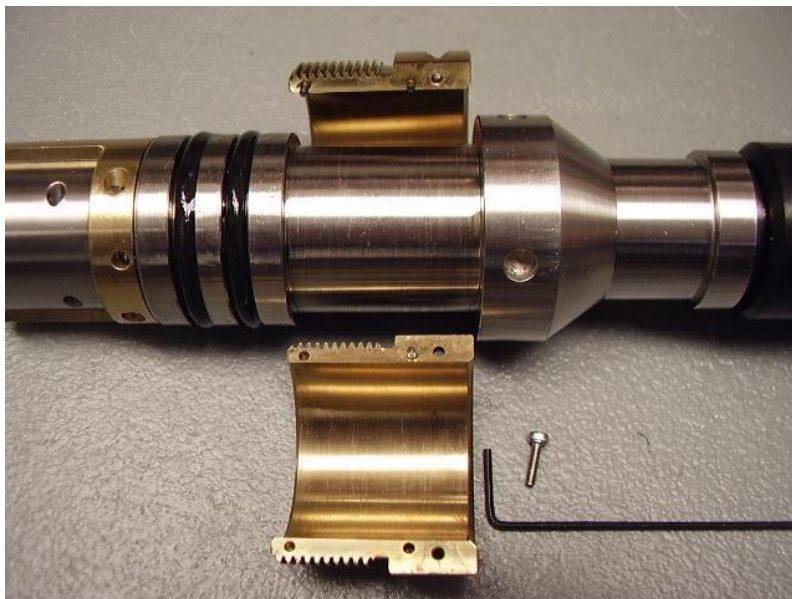

Figure 5-2 Halves rings when pulled apart

Clean inside surfaces thoroughly and reassemble, coating the inside with a very light film of anti-seize compound. Nickel based compounds are best, to prevent any sticking between the brass and steel surfaces.

6 Troubleshooting

In the event the tool develops a problem, follow the troubleshooting procedure listed below.

WARNING: NEVER DIS-ASSEMBLE THE PROBE WITHOUT KNOWLEDGE OF PROCEDURE

Observation	To Do
<i>Tool not listed in Tool panel drop down list.</i>	<ul style="list-style-type: none"> - Do you have a configuration file? - Has the configuration file been installed with the LoggerSettings application (refer to LoggerSettings and LoggerSuite manuals for more information)
<i>Tool configuration error message when powering on the tool.</i>	<ul style="list-style-type: none"> - Check all connections. - Adjust the telemetry settings for your wireline configuration (see chapter 4.2 and 4.3) and store the new settings as default. Apply the appropriate tool settings for your logging run.
<i>Tool panel - No current.</i>	<ul style="list-style-type: none"> - Verify that the wireline armor is connected to the logging system. Verify the interface cable between winch slip ring and data acquisition system is not loose at the connectors. Test the interface cable between winch and data acquisition system. - Verify cable head integrity. Cable head should have more than 20 Mega Ohm resistance electrical isolation. - Check wireline conductor and armor continuity. - Verify DC voltage output at the cable head (it should be 120V).
<i>Tool panel - Too much current (red area).</i>	<p>! Immediately turn off the tool !</p> <ul style="list-style-type: none"> - Possible shortcut (voltage low, current high): Check for water ingress and cable head integrity. - Verify cable head isolation integrity. Cable head should have more than 20 Mega Ohm resistance electrical isolation. - Verify the interface cable between winch slip ring and data acquisition system is not loose at the connectors. Check for possible source of the short circuit. - If the above shows no issues, use test cable (optional) provided by ALT or MSI to verify tool functionality. - If the problem still occurs, please contact service centre.
<i>Telemetry panel - status shows red.</i>	<ul style="list-style-type: none"> - Verify the telemetry settings for your wireline configuration (see chapter 4.2 and 4.3). - If problem cannot be resolved, contact support@alt.lu or tech.support@mountsopris.com

<i>Telemetry panel - memory buffer shows 100%.</i>	- Indicates that the systems internal memory buffer is full. PC cannot receive incoming data streams fast enough. Ensure your PC has enough resources available.
<i>Telemetry panel – bandwidth usage shows 100%. (Overrun error message.)</i>	- Set the baud rate to highest value allowed by your wireline configuration. - Reduce logging speed or increase vertical sample step.
<i>Telemetry panel - large number of errors.</i>	- Verify the telemetry settings for your wireline configuration (see chapter 3.2 or 3.3). - Check bandwidth usage and telemetry error status.

7 Appendix

7.1 Replacement Parts

Item No.	Qty	MSI Part No.	Description
1	1	17-202-160	Mag Susc. Calibration Puck, .5 x 10-3 SI units
2	1	17-202-175	Mag Susc. Calibration Puck, 2.4 x 10-3 SI units
3	1	17-202-176	Mag Susc. Calibration Puck, 5 x 10-3 SI units
4	1	17-202-177	Mag Susc. Calibration Puck 2 x 10-1 SI units
5	1	16-201-007	Silicone Lubricant Cartridge 14.1 oz.
6	1	54-203-216	Grease Gun #4BY69 for 14.1 oz.
7	1	17-202-178	Mag Susc. Calibration Puck Mount
8	1	54-101-921	C-Spanner Wrench
9	1	ALT26305	Q40 Plastic Female Plug
10	1	ALT26306	Q40 Plastic Male Lid

7.2 Other Parts

Item No.	MSI Part No.	ALT Part No.	Description
1	QL40-GO1	ALT 26312-00	QL40-GO1 tool top
2	QL40-GO4	ALT 26074-00 (T1)	QL40-GO4 tool top
3	QL40-MS1	ALT 26084-00 (T0)	QL40-MS1 tool top

8 Probe Tops - Standard Configurations

8.1 QL40-GO4 Four Conductor Tool Top

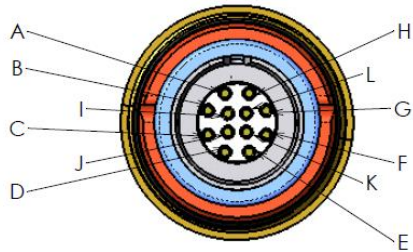

Figure 8-1 QL40-GO4 bottom connection to tool

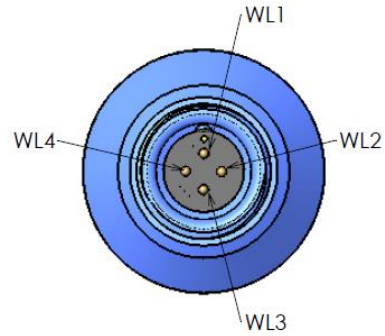
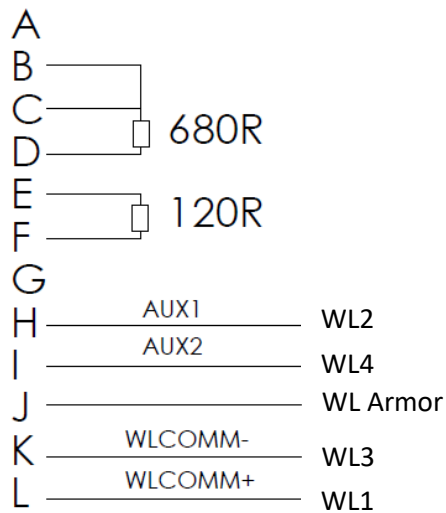

Figure 8-2 QL40-GO4 top connection to cable head



8.2 QL40-MS1 and QL40-GO1 Single Conductor Tool Tops

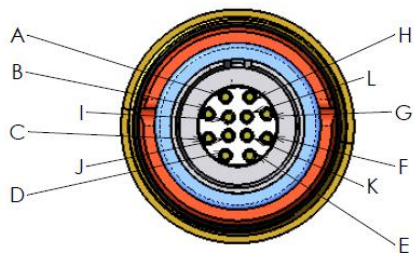

Figure 8-3 QL40-MS1 bottom connection to tool



Figure 8-4 QL40-MS1 top connection to cable head

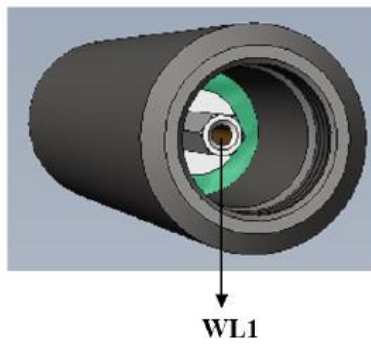

Figure 8-5 QL40-GO1 top connection to cable head

